

ASAHI

BEARING UNITS

**JOINBAL
ROD ENDS
SPHERICAL BEARINGS**



JP-1973



ISO9001
JQA-1973



ASAHI SEIKO CO., LTD.

CONTENTS

BEARING UNITS

General Introduction	1 ~ 3
Dimension Tables	4 ~ 55
Silver Series & Stainless Silver Series	56 ~ 60
Engineering Data	61 ~ 79
Load Rating Data	80 ~ 82

ROD ENDS & SPHERICAL BEARINGS

General Introduction	84 ~ 85
Dimension Tables	86 ~ 89
Engineering Data	90 ~ 93

CONVERSION TABLES	94 ~ 96
-----------------------------	---------

Note) Types and bearing sizes marked (*) including Bearing Units incorporating such bearings are not normally stocked or regularly produced. Check availability when ordering.

ASAHI BEARING UNITS

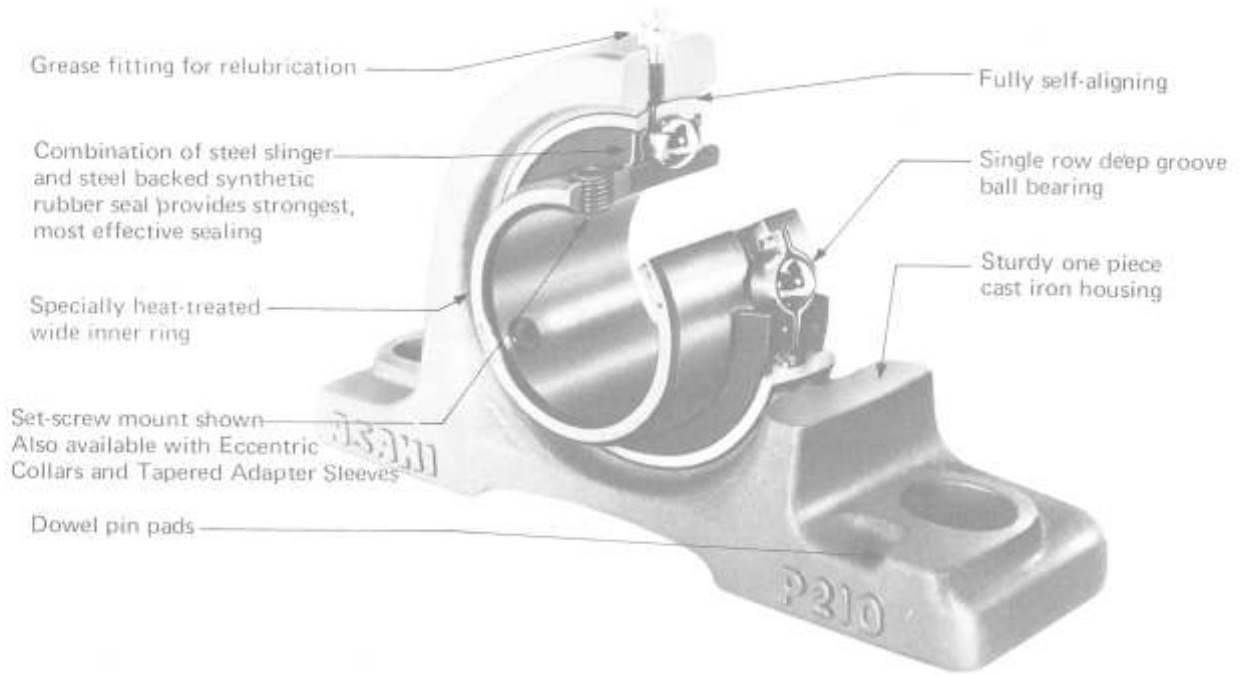

Pillow Block with Internal Eccentric Locking Collar



Pillow Block with Cast Iron Covers



Pillow Block with Pressed Steel Covers



ASAHI BEARING UNITS

CONSTRUCTION OF BEARING UNITS

ASAHI Bearing Units consist of a double sealed single row deep groove ball bearing and any one of cast iron, synthetic rubber or pressed steel housings of various configurations.

The self-contained bearing with spherical ground outside diameter is assembled into a corresponding spherical seat of the housing providing self-alignment of the bearing in the housing at

FEATURES OF BEARING UNITS

Rational self-alignment

The outside diameter of the self-contained bearing is ground spherical to match corresponding spherical inside diameter of the housing providing self-alignment between these two members, which compensates for misalignments of the units resulting from errors in mounting and distortion of the foundation.

Larger load carrying capacity

Being the same as 6200 and 6300 series single row deep groove radial ball bearings in internal construction of the self-contained bearing, Bearing Units can sustain radial loads and substantial thrust loads as well. Quiet operation is also assured.

Longer service life

Bearing Units are often used in severe operating conditions where they are exposed to dirt, moisture or high temperature, and in such applications, the grease inside the self-contained bearing deteriorates in a short period of time. It is required, therefore to relubricate the units at suitable intervals so as to replace deteriorated grease with fresh grease.

ASAHI Bearing Units with cast iron and rubber housings are all relubricable type equipped with grease fittings to secure full performance and longer service life of the units under any operating condition.

Efficient sealing

The self-contained bearing is double sealed with a combination of heat-resistant oil-proof synthetic rubber seal and steel slinger. The outside steel slinger which is fixed to the inner ring and rotates together with it effectively prevents foreign matters from entering into the bearing from the atmosphere and protects the bearing against outside pressure. The steel backed rubber seal on inside which is fixed to the outer ring contacts the land of the inner ring with a light rubbing pressure. The combination of these two sealing elements serve to exclude dirt and moisture and to retain the grease within the bearing chamber insuring full performance of the bearing even in severe operating conditions. Bearing Units with Covers are developed for applications where surroundings and atmospheric conditions are extremely severe such as in steel mills, flour mills, foundries, etc. With the double sealing of the self-contained bearing and dust covers of the housing, sealing ability of the units with covers is perfect.

Solid housing

The cast iron housing is of solid one-piece construction to provide maximum rigidity against deformation at mounting and wear resistance for any operating condition.

mounting. Set-screw locking is most popular method of mounting to the shaft. Adapter sleeve and eccentric locking collar are also available. For services under more severe operating conditions, Bearing Units with Cast Iron Covers and Pressed Steel Covers are available as standard types.

Easy and positive locking to shaft

There are three methods of locking Bearing Units to the shaft. Locking by means of two set-screws in the extended inner ring is the most common method. Adapter sleeve locking and an eccentric locking collar are also available. All these locking methods offer easy installation of the units and machining of the shafts.

Special heat-treatment on bearing inner ring

As shown in the figure below, the inner ring of the self-contained bearing is hardened in the race-way and surrounding part where hardening is necessary, while the extended part where the set-screws are installed is left metallurgically mild and tenacious. This special heat-treatment ensures full bearing performance and prevents the set-screws from loosening during operation as the set-screws can be tightened hard enough without causing destructive inner ring cracking.

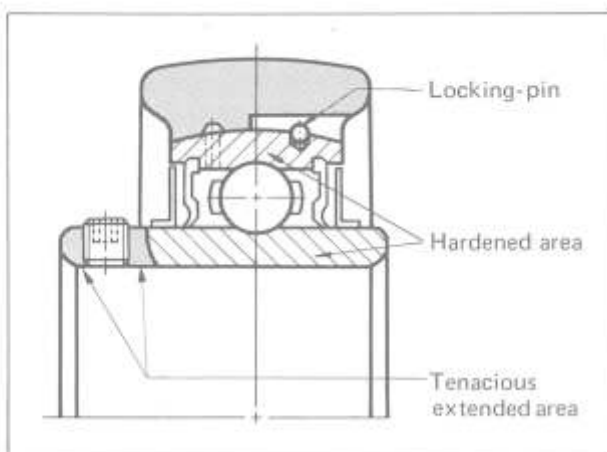

Unique device to prevent bearing outer ring rotation

The bearing outer ring is equipped with a unique locking-pin device which permits free self-alignment of the units, and also prevents outer ring rotation. The result - longer service life.

Complete interchangeability between bearing and housing

Skilled precision workmanship on the self-contained bearing and the housing provides complete interchangeability between them and the bearing can be easily replaced whenever so required.







Easy installation



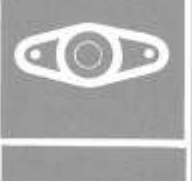

The self-contained bearing is prelubricated with an adequate quantity of high quality grease. Bearing Units can be mounted on the shaft for immediate operation. The units are, therefore, free from ingress of harmful contaminants into the bearing chamber during mounting procedures.

Easy positioning for mounting

Two dowel bases provided on the housing of Pillow Block, Square Flange and Two-Bolt Flange Units serve for easy and accurate positioning of the units when mounting them on the structure.

DIMENSION TABLE INDEX

	Type of Housing	Material of Housing	Series No.	Page
	Pillow Blocks	Cast Iron	UCP 200	6
			UCLP 200	6
			UCP X00	7
			UCP 300	7
			UKP 200+H	8
			UKP X00+H	8
			UKP 300+H	9
			UDP 200	9
			CUCP 200C (CE)	10
			UCP 200C (E)	10
			UCIP 200	11
			UCIP 300	11
			UCPH 200	12
UCPA 200	12			
UCEP 200	13			
	Rubber	UCRP 200	13	
	Cast Iron	BP 200	14	
		BLLP	14	
	Pressed Steel	BPP	15	
		BPR KHPR 200	15	
	Cast Steel	UCPK 200	16	
	Malleable Cast	BPW	16	
		KHPW 200	16	
	Square Flange	Cast Iron	UCF 200	17
			UCLF 200	17
			UCF X00	18
			UCF 300	18
			UKF 200+H	19
			UKF X00+H	19
			UKF 300+H	20
			UDF 200	20
			CUCF 200C (CE)	21
			UCF 200C (E)	21
			BF 200	22
	Three-Bolt Flange	Pressed Steel	BPF	22
			BPFT	22
	Flange Cartridge	Cast Iron	UCFC 200	23
			UCFC X00	23
			UCFS 300	24
			UDFC 200	24
			CUCFC 200C (CE)	25
			UCFC 200C (E)	25
	Two-Bolt Flange	Cast Iron	UCFL 200	26
			UCFT 200	26
			UCFL X00	27
			UCFL 300	27
			UDFL 200	28
			CUCFL 200C (CE)	29
			UCFL 200C (E)	29
			BFL 200	30
			BLFL	30
				Pressed Steel
	Malleable Cast	BFX 200	31	
		KHFX 200	31	
	Adjustable Flange	Cast Iron	UCFA 200	32

	Type of Housing	Material of Housing	Series No.	Page
	Flange Bracket	Cast Iron	UCFK 200	32
	Take-Up	Cast Iron	UCT 200 UCST 200 UCT X00 UCT 300 UDT 200 CUCT 200C (CE) UCT 200C (E) BT 200	33 33 34 34 35 36 36 37
	Take-Up with Frame	Cast Iron	UCT 200+WB UCTU 200+WU UCTL 200+WL	38 39 39
	Cartridge	Cast Iron	UCC 200 UCLC 200 UCC X00 UCC 300	40 40 41 41
	Hanger Bearing	Cast Iron	UCECH 200	42
	Two-Bolt Flange		BLCTE 200K	42

	Ball Bearings	Locking Method	Series No.	Page
		Set-Screw	UC 200	44
			UCW 200	45
			UC X00	46
			UC 300	47
		Adapter Sleeve	UK 200+H	48
UK X00+H UK 300+H	49 50			
Eccentric Collar	UD 200+EE	51		
Set-Screw	B	52		
	SER 200	53		
Eccentric Collar	UG 200+ER	54		
	KH 200+AE	55		
Silver Series	Pillow Blocks	Material of Housing Special Alloy	UP 000	57
			MUP 000	59
Stainless Silver Series	Two-Bolt Flange Units	Locking Method Eccentric Collar	UFL 000	58
			MUFL 000	60

Note: For load ratings at various RPM's and life hours in Kilograms (Pounds), see Page 76 and 77.
Basic dynamic and static load ratings of specific bearing size in Newton are shown on Page 78.

PILLOW BLOCKS

UCP 200 type

Normal Duty
Set-screw Locking

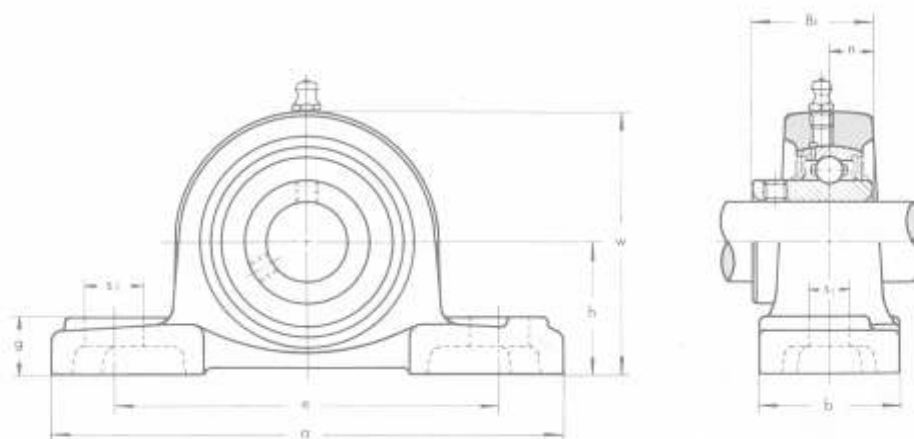

Unit No.	Shaft Diam. mm	Dimensions mm										Bolt Size mm	Bearing No.	Housing No.	Weight kg
		h	a	e	b	s ₁	s ₂	g	w	Bi	n				
UCP 201	12	30.2	127	95	38	13	19	15	62	31	12.7	M10	UC 201	P 203	0.65
UCP 202	15	30.2	127	95	38	13	19	15	62	31	12.7	M10	UC 202	P 203	0.63
UCP 203	17	30.2	127	95	38	13	19	15	62	31	12.7	M10	UC 203	P 203	0.62
UCP 204	20	33.3	127	95	38	13	19	15	65	31	12.7	M10	UC 204	P 204	0.65
UCP 205	25	36.5	140	105	38	13	16	16	70	34.1	14.3	M10	UC 205	P 205	0.79
UCP 206	30	42.9	165	121	48	17	21	18	83	38.1	15.9	M14	UC 206	P 206	1.3
UCP 207	35	47.6	167	127	48	17	21	19	94	42.9	17.5	M14	UC 207	P 207	1.6
UCP 208	40	49.2	184	137	54	17	25	19	100	49.2	19	M14	UC 208	P 208	2.0
UCP 209	45	54	190	146	54	17	22	20	108	49.2	19	M14	UC 209	P 209	2.3
UCP 210	50	57.2	206	159	60	20	25	22	114	51.6	19	M16	UC 210	P 210	2.7
UCP 211	55	63.5	219	171	60	20	25	22	126	55.6	22.2	M16	UC 211	P 211	3.3
UCP 212	60	69.8	241	184	70	20	25	25	138	65.1	25.4	M16	UC 212	P 212	4.7
UCP 213	65	76.2	265	203	70	25	29	27	150	65.1	25.4	M20	UC 213	P 213	5.6
UCP 214	70	79.4	266	210	72	25	31	27	156	74.6	30.2	M20	UC 214	P 214	7.3
UCP 215	75	82.6	275	217	74	25	31	28	163	77.8	33.3	M20	UC 215	P 215	7.9
UCP 216	80	88.9	292	232	78	25	31	30	175	82.6	33.3	M20	UC 216	P 216	10.0
UCP 217	85	95.2	310	247	83	25	31	32	187	85.7	34.1	M20	UC 217	P 217	12.2
UCP 218	90	101.6	327	262	88	27	33	34	200	96	39.7	M22	UC 218	P 218	14.7

PILLOW BLOCKS

* UCLP 200 type

Normal Duty
Set-screw Locking
Low Base-to-Center Height

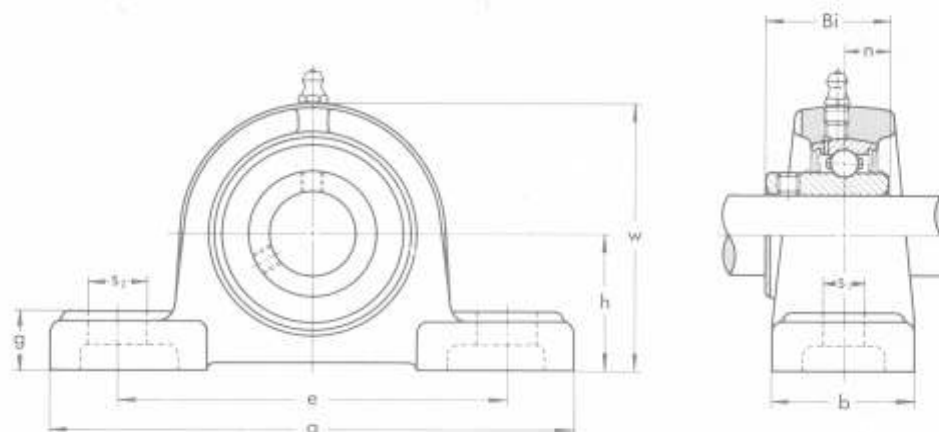

Unit No.	Shaft Diam. mm	Dimensions mm										Bolt Size mm	Bearing No.	Housing No.	Weight kg
		h	a	e	b	s ₁	s ₂	g	w	Bi	n				
UCLP 201	12	27	121	89	29	12	16	13	56	26	10	M10	UCW 201	LP 203	0.50
UCLP 202	15	27	121	89	29	12	16	13	56	26	10	M10	UCW 202	LP 203	0.49
UCLP 203	17	27	121	89	29	12	16	13	56	26	10	M10	UCW 203	LP 203	0.48
UCLP 204	20	31.8	133	98	32	12	19	13	65	31	12.7	M10	UC 204	LP 204	0.67
UCLP 205	25	33.3	140	105	38	12	19	16	68	34.1	14.3	M10	UC 205	LP 205	0.80
UCLP 206	30	39.7	165	124	41	15	22	17	81	38.1	15.9	M12	UC 206	LP 206	1.2
UCLP 207	35	46	178	137	48	15	22	19	94	42.9	17.5	M12	UC 207	LP 207	1.9
UCLP 208	40	49.2	184	143	51	15	22	21	100	49.2	19	M12	UC 208	LP 208	2.2
UCLP 209	45	52.4	197	152	54	15	25	21	106	49.2	19	M12	UC 209	LP 209	2.4
UCLP 210	50	55.6	213	165	57	15	25	22	113	51.6	19	M12	UC 210	LP 210	2.9
UCLP 211	55	61.9	235	181	64	19	29	25	125	55.6	22.2	M16	UC 211	LP 211	4.0
UCLP 212	60	68.3	248	194	70	19	29	29	138	65.1	25.4	M16	UC 212	LP 212	5.3
UCLP 213	65	68.3	248	194	70	19	29	29	138	65.1	25.4	M16	UC 213	LP 213	5.1

PILLOW BLOCKS

UCP X00 type

Medium Duty
Set-screw Locking

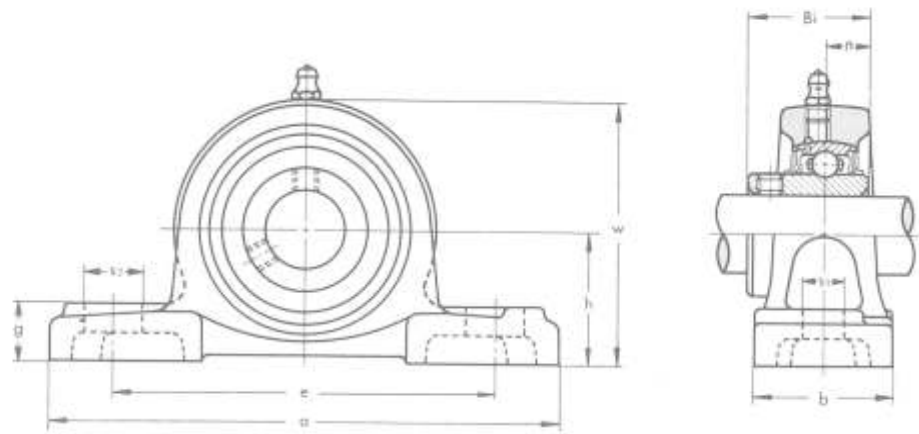

Unit No.	Shaft Diam. mm	Dimensions mm										Bolt Size mm	Bearing No.	Housing No.	Weight kg
		h	a	e	b	s ₁	s ₂	g	w	Bi	n				
UCP X05	25	44.4	159	119	51	17	25	18	85	38.1	15.9	M14	UC X05	P X05	1.5
UCP X06	30	47.6	175	127	57	17	25	20	94	42.9	17.5	M14	UC X06	P X06	1.9
UCP X07	35	54	203	144	57	17	30	22	105	49.2	19	M14	UC X07	P X07	2.7
UCP X08	40	58.7	222	156	67	20	32	26	113	49.2	19	M16	UC X08	P X08	3.5
UCP X09	45	58.7	222	156	67	20	33	26	116	51.6	19	M16	UC X09	P X09	3.5
UCP X10	50	63.5	241	171	73	20	36	27	126	55.6	22.2	M16	UC X10	P X10	4.2
UCP X11	55	69.8	260	184	79	25	36	30	139	65.1	25.4	M20	UC X11	P X11	5.9
UCP X12	60	76.2	286	203	83	25	41	32	151	65.1	25.4	M20	UC X12	P X12	7.2
UCP X13	65	76.2	286	203	83	25	41	32	154	74.6	30.2	M20	UC X13	P X13	7.4
UCP X14	70	88.9	330	229	89	27	51	35	172	77.8	33.3	M22	UC X14	P X14	11.1
UCP X15	75	88.9	330	229	89	27	51	35	177	82.6	33.3	M22	UC X15	P X15	11.4
UCP X16	80	101.6	381	283	102	27	59	42	197	85.7	34.1	M22	UC X16	P X16	17.4
UCP X17	85	101.6	381	283	102	27	59	42	202	96	39.7	M22	UC X17	P X17	17.1
UCP X18	90	101.6	381	283	111	27	60	45	206	104	42.9	M22	UC X18	P X18	17.0
UCP X20	100	127	432	337	121	33	64	52	250	117.5	49.2	M27	UC X20	P X20	33.0

PILLOW BLOCKS

UCP 300 type

Heavy Duty
Set-screw Locking

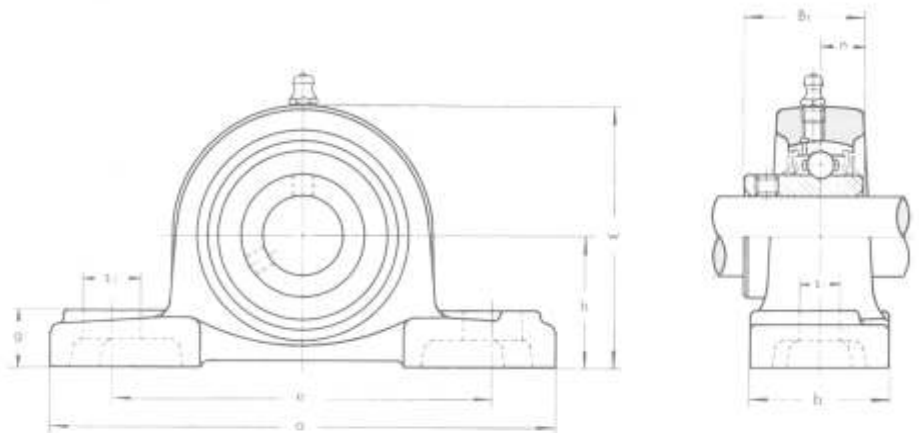

Unit No.	Shaft Diam. mm	Dimensions mm										Bolt Size mm	Bearing No.	Housing No.	Weight kg
		h	a	e	b	s ₁	s ₂	g	w	Bi	n				
UCP 305	25	45	175	132	45	17	20	16	83	38	15	M14	UC 305	P 305	1.6
UCP 306	30	50	180	140	50	17	20	19	94	43	17	M14	UC 306	P 306	1.9
UCP 307	35	56	210	160	56	17	25	21	105	48	19	M14	UC 307	P 307	2.7
UCP 308	40	60	220	170	60	17	27	23	116	52	19	M14	UC 308	P 308	3.3
UCP 309	45	67	245	190	67	20	30	25	128	57	22	M16	UC 309	P 309	4.5
UCP 310	50	75	275	212	75	20	35	28	143	61	22	M16	UC 310	P 310	6.2
UCP 311	55	80	310	236	80	20	38	31	154	66	25	M16	UC 311	P 311	7.7
UCP 312	60	85	330	250	85	25	38	33	165	71	26	M20	UC 312	P 312	9.3
UCP 313	65	90	340	260	90	25	38	36	174	75	30	M20	UC 313	P 313	9.8
UCP 314	70	95	360	280	90	27	40	40	186	78	33	M22	UC 314	P 314	11.4
UCP 315	75	100	380	290	100	27	40	40	197	82	32	M22	UC 315	P 315	13.6
UCP 316	80	106	400	300	110	27	40	45	209	86	34	M22	UC 316	P 316	16.4
UCP 317	85	112	420	320	110	33	45	45	221	96	40	M27	UC 317	P 317	18.6
UCP 318	90	118	430	330	110	33	45	50	233	96	40	M27	UC 318	P 318	20.9
UCP 319	95	125	470	360	120	36	50	50	250	103	41	M30	UC 319	P 319	26.5
UCP 320	100	140	490	380	120	36	50	55	275	108	42	M30	UC 320	P 320	34.3
UCP 321	105	140	490	380	120	36	50	55	278	112	44	M30	UC 321	P 321	36.6
UCP 322	110	150	520	400	140	40	55	60	295	117	46	M33	UC 322	P 322	42.5
UCP 324	120	160	570	450	140	40	55	70	321	126	51	M33	UC 324	P 324	53.5
UCP 326	130	180	600	480	140	40	55	80	354	135	54	M33	UC 326	P 326	72.1
UCP 328	140	200	620	500	140	40	55	80	388	145	59	M33	UC 328	P 328	89.1

PILLOW BLOCKS

UKP 200+H type

Normal Duty
Adapter Sleeve Locking

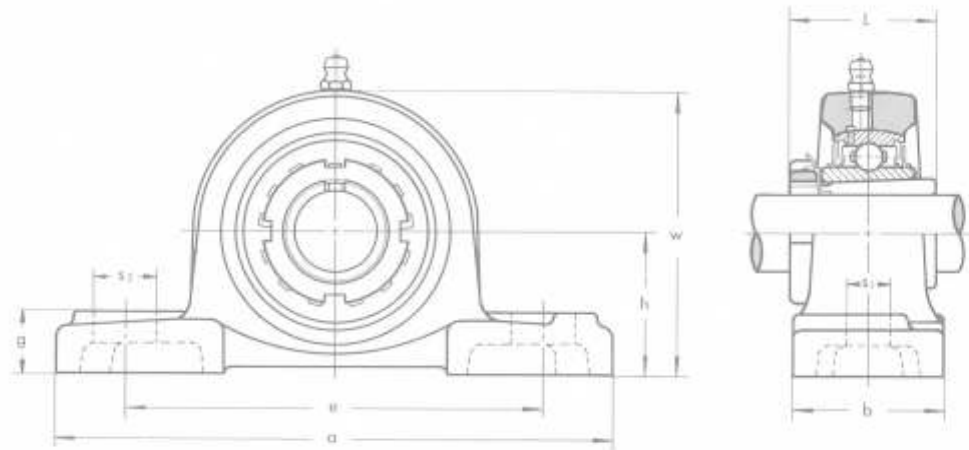

Unit No.	Shaft Diam. mm	Dimensions mm									Bolt Size mm	Bearing No.	Housing No.	Weight kg
		h	a	e	b	s ₁	s ₂	g	w	L				
UKP 205+H2305	20	36.5	140	105	38	13	16	16	70	35	M10	UK 205+H2305	P 205	0.84
UKP 206+H2306	25	42.9	165	121	48	17	21	18	83	38	M14	UK 206+H2306	P 206	1.4
UKP 207+H2307	30	47.6	167	127	48	17	21	19	94	43	M14	UK 207+H2307	P 207	1.6
UKP 208+H2308	35	49.2	184	137	54	17	25	19	100	46	M14	UK 208+H2308	P 208	2.1
UKP 209+H2309	40	54	190	146	54	17	22	20	108	50	M14	UK 209+H2309	P 209	2.4
UKP 210+H2310	45	57.2	206	159	60	20	25	22	114	55	M16	UK 210+H2310	P 210	2.8
UKP 211+H2311	50	63.5	219	171	60	20	25	22	126	59	M16	UK 211+H2311	P 211	3.4
UKP 212+H2312	55	69.8	241	184	70	20	25	25	138	62	M16	UK 212+H2312	P 212	4.8
UKP 213+H2313	60	76.2	265	203	70	25	29	27	150	65	M20	UK 213+H2313	P 213	5.7
UKP 215+H2315	65	82.6	275	217	74	25	31	28	163	73	M20	UK 215+H2315	P 215	8.3
UKP 216+H2316	70	88.9	292	232	78	25	31	30	175	78	M20	UK 216+H2316	P 216	10.4
UKP 217+H2317	75	95.2	310	247	83	25	31	32	187	82	M20	UK 217+H2317	P 217	12.8
UKP 218+H2318	80	101.6	327	262	88	27	33	34	200	86	M22	UK 218+H2318	P 218	15.1

PILLOW BLOCKS

UKP X00+H type

Medium Duty
Adapter Sleeve Locking

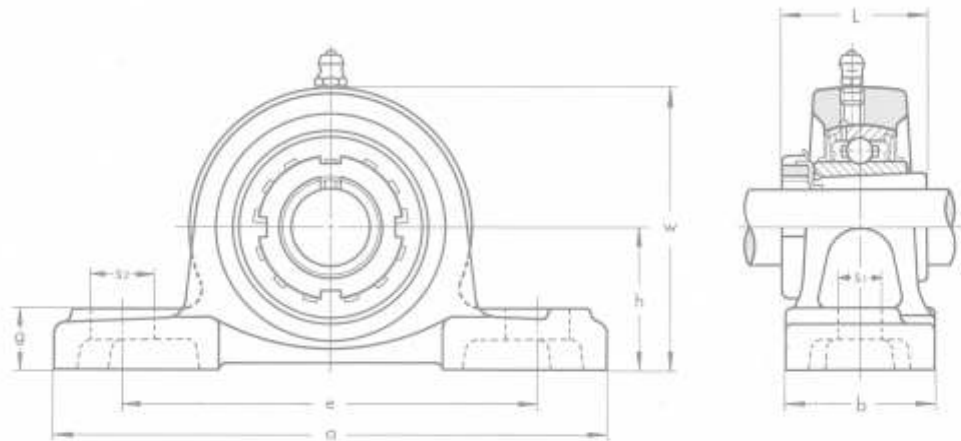

Unit No.	Shaft Diam. mm	Dimensions mm									Bolt Size mm	Bearing No.	Housing No.	Weight kg
		h	a	e	b	s ₁	s ₂	g	w	L				
UKP X05+H2305	20	44.4	159	119	51	17	25	18	85	35	M14	UK X05+H2305	P X05	1.5
UKP X06+H2306	25	47.6	175	127	57	17	25	20	94	38	M14	UK X06+H2306	P X06	2.0
UKP X07+H2307	30	54	203	144	57	17	30	22	105	43	M14	UK X07+H2307	P X07	2.7
UKP X08+H2308	35	58.7	222	156	67	20	32	26	113	46	M16	UK X08+H2308	P X08	3.5
UKP X09+H2309	40	58.7	222	156	67	20	33	26	116	50	M16	UK X09+H2309	P X09	3.5
UKP X10+H2310	45	63.5	241	171	73	20	36	27	126	55	M16	UK X10+H2310	P X10	4.3
UKP X11+H2311	50	69.8	260	184	79	25	36	30	139	59	M20	UK X11+H2311	P X11	5.8
UKP X12+H2312	55	76.2	286	203	83	25	41	32	151	62	M20	UK X12+H2312	P X12	7.1
UKP X13+H2313	60	76.2	286	203	83	25	41	32	154	65	M20	UK X13+H2313	P X13	7.2
UKP X15+H2315	65	88.9	330	229	89	27	51	35	177	73	M22	UK X15+H2315	P X15	11.5
UKP X16+H2316	70	101.6	381	283	102	27	59	42	197	78	M22	UK X16+H2316	P X16	17.4
UKP X17+H2317	75	101.6	381	283	102	27	59	42	202	82	M22	UK X17+H2317	P X17	17.0
UKP X18+H2318	80	101.6	381	283	111	27	60	45	206	86	M22	UK X18+H2318	P X18	16.7
UKP X20+H2320	90	127	432	337	121	33	64	52	250	97	M27	UK X20+H2320	P X20	32.1

PILLOW BLOCKS

UKP 300+H type

Heavy Duty
Adapter Sleeve Locking

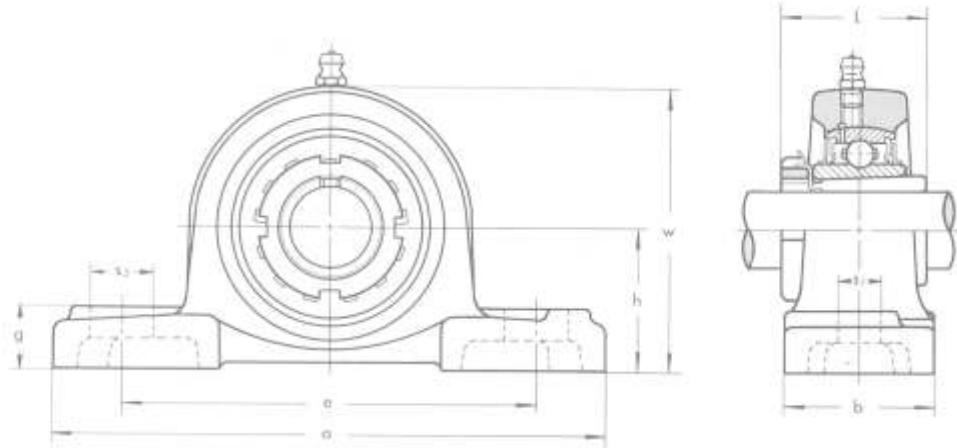

Unit No.	Shaft Diam. mm	Dimensions mm									Bolt Size mm	Bearing No.	Housing No.	Weight kg
		h	a	e	b	s ₁	s ₂	g	w	L				
UKP 305+H 2305	20	45	175	132	45	17	20	16	83	35	M14	UK 305+H 2305	P 305	1.6
UKP 306+H 2306	25	50	180	140	50	17	20	19	94	38	M14	UK 306+H 2306	P 306	1.9
UKP 307+H 2307	30	56	210	160	56	17	25	21	105	43	M14	UK 307+H 2307	P 307	2.7
UKP 308+H 2308	35	60	220	170	60	17	27	23	116	46	M14	UK 308+H 2308	P 308	3.0
UKP 309+H 2309	40	67	245	190	67	20	30	25	128	50	M16	UK 309+H 2309	P 309	4.6
UKP 310+H 2310	45	75	275	212	75	20	35	28	143	55	M16	UK 310+H 2310	P 310	6.2
UKP 311+H 2311	50	80	310	236	80	20	38	31	154	59	M16	UK 311+H 2311	P 311	7.9
UKP 312+H 2312	55	85	330	250	85	25	38	33	165	62	M20	UK 312+H 2312	P 312	9.3
UKP 313+H 2313	60	90	340	260	90	25	38	36	174	65	M20	UK 313+H 2313	P 313	9.8
UKP 315+H 2315	65	100	380	290	100	27	40	40	197	73	M22	UK 315+H 2315	P 315	13.7
UKP 316+H 2316	70	106	400	300	110	27	40	45	209	78	M22	UK 316+H 2316	P 316	16.6
UKP 317+H 2317	75	112	420	320	110	33	45	45	221	82	M27	UK 317+H 2317	P 317	18.6
UKP 318+H 2318	80	118	430	330	110	33	45	50	233	86	M27	UK 318+H 2318	P 318	21.1
UKP 319+H 2319	85	125	470	360	120	36	50	50	250	90	M30	UK 319+H 2319	P 319	26.5
UKP 320+H 2320	90	140	490	380	120	36	50	55	275	97	M30	UK 320+H 2320	P 320	34.3
UKP 322+H 2322	100	150	520	400	140	40	55	60	295	105	M33	UK 322+H 2322	P 322	42.6
UKP 324+H 2324	110	160	570	450	140	40	55	70	321	112	M33	UK 324+H 2324	P 324	53.0
UKP 326+H 2326	115	180	600	480	140	40	55	80	354	121	M33	UK 326+H 2326	P 326	72.4
UKP 328+H 2328	125	200	620	500	140	40	55	80	388	131	M33	UK 328+H 2328	P 328	89.4

PILLOW BLOCKS

*UDP 200 type

Normal Duty
Eccentric Collar Locking

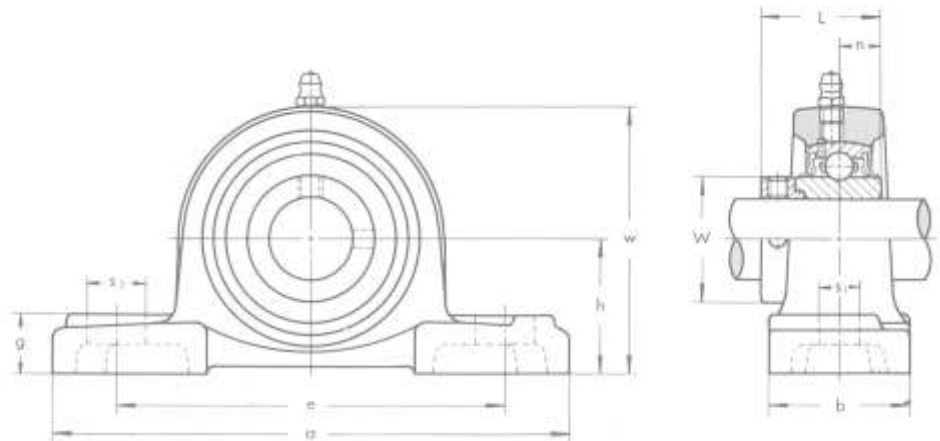

Unit No.	Shaft Diam. mm	Dimensions mm											Bolt Size mm	Bearing No.	Housing No.	Weight kg
		h	a	e	b	s ₁	s ₂	g	w	L	n	W				
UDP 204	20	33.3	127	95	38	13	19	15	65	31	11.5	29	M10	UD 204 +EE	P 204	0.65
UDP 205	25	36.5	140	105	38	13	16	16	70	32	11.5	34	M10	UD 205 +EE	P 205	0.78
UDP 206	30	42.9	165	121	48	17	21	18	83	36	13	40	M14	UD 206 +EE	P 206	1.3
UDP 207	35	47.6	167	127	48	17	21	19	94	38	13.5	48	M14	UD 207 +EE	P 207	1.5
UDP 208	40	49.2	184	137	54	17	25	19	100	40	14.5	53	M14	UD 208 +EE	P 208	1.9
UDP 209	45	54	190	146	54	17	22	20	108	42	15	57	M14	UD 209 +EE	P 209	2.2
UDP 210	50	57.2	206	159	60	20	25	22	114	43	15.5	63	M16	UD 210 +EE	P 210	2.6

PILLOW BLOCKS WITH CAST IRON COVERS

CUCP 200C (CE) type

Normal Duty
Set-screw Locking

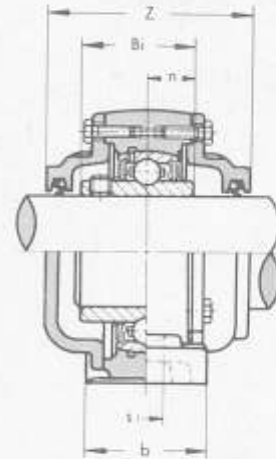
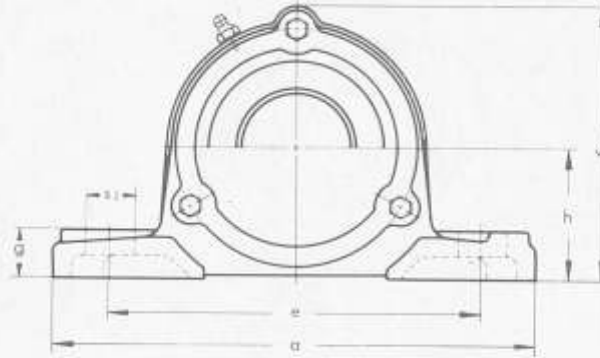

Unit No.		Shaft Diam. mm	Dimensions mm											Ball Size mm	Bearing No.	Housing No.	Weight kg
Open Cover	Closed Cover		h	a	e	b	s ₁	s ₂	g	w	Z	Bi	n				
CUCP 201C	CUCP 201CE	12	30.2	127	95	38	13	19	15	66	62	31	12.7	M10	UC 201	CP 203	1.1
CUCP 202C	CUCP 202CE	15	30.2	127	95	38	13	19	15	66	62	31	12.7	M10	UC 202	CP 203	1.1
CUCP 203C	CUCP 203CE	17	30.2	127	95	38	13	19	15	66	62	31	12.7	M10	UC 203	CP 203	1.1
CUCP 204C	CUCP 204CE	20	33.3	127	95	38	13	19	15	69	62	31	12.7	M10	UC 204	CP 204	1.1
CUCP 205C	CUCP 205CE	25	36.5	140	105	38	13	16	16	76	70	34.1	14.3	M10	UC 205	CP 205	1.4
CUCP 206C	CUCP 206CE	30	42.9	165	121	48	17	21	18	87	74	38.1	15.9	M14	UC 206	CP 206	2.0
CUCP 207C	CUCP 207CE	35	47.6	167	127	48	17	21	19	97	80	42.9	17.5	M14	UC 207	CP 207	2.5
CUCP 208C	CUCP 208CE	40	49.2	184	137	54	17	25	19	104	90	49.2	19	M14	UC 208	CP 208	3.0
CUCP 209C	CUCP 209CE	45	54	190	146	54	17	22	20	114	90	49.2	19	M14	UC 209	CP 209	3.4
CUCP 210C	CUCP 210CE	50	57.2	206	159	60	20	25	22	120	98	51.6	19	M16	UC 210	CP 210	4.1
CUCP 211C	CUCP 211CE	55	63.5	219	171	60	20	25	22	133	100	55.6	22.2	M16	UC 211	CP 211	5.0
CUCP 212C	CUCP 212CE	60	69.8	241	184	70	20	25	25	145	114	65.1	25.4	M16	UC 212	CP 212	6.7
CUCP 213C	CUCP 213CE	65	76.2	265	203	70	25	29	27	156	118	65.1	25.4	M20	UC 213	CP 213	7.8
CUCP 214C	CUCP 214CE	70	79.4	266	210	72	25	31	27	162	134	74.6	30.2	M20	UC 214	CP 214	9.3
CUCP 215C	CUCP 215CE	75	82.6	275	217	74	25	31	28	167	136	77.8	33.3	M20	UC 215	CP 215	9.6
CUCP 216C	CUCP 216CE	80	88.9	292	232	78	25	31	30	188	146	82.6	33.3	M20	UC 216	CP 216	12.2
CUCP 217C	CUCP 217CE	85	95.2	310	247	83	25	31	32	199	150	85.7	34.1	M20	UC 217	CP 217	14.2
CUCP 218C	CUCP 218CE	90	101.6	327	262	88	27	33	34	211	164	96	39.7	M22	UC 218	CP 218	18.2

PILLOW BLOCKS WITH PRESSED STEEL COVERS

UCP 200C (E) type

Normal Duty
Set-screw Locking

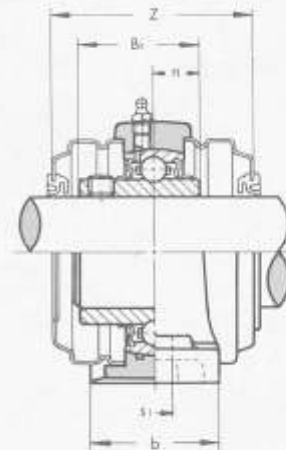
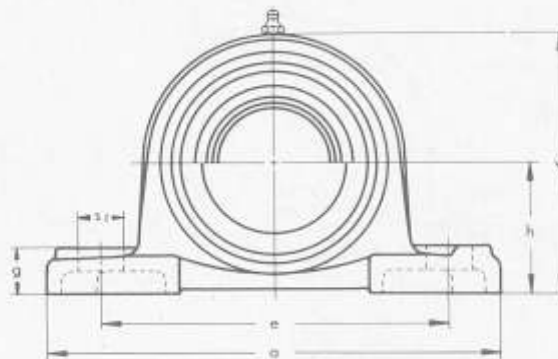

Unit No.		Shaft Diam. mm	Dimensions mm											Ball Size mm	Bearing No.	Housing No.	Weight kg
Open Cover	Closed Cover		h	a	e	b	s ₁	s ₂	g	w	Z	Bi	n				
UCP 201C	UCP 201E	12	30.2	127	95	38	13	19	15	62	56	31	12.7	M10	UC 201	P 203C	0.71
UCP 202C	UCP 202E	15	30.2	127	95	38	13	19	15	62	56	31	12.7	M10	UC 202	P 203C	0.69
UCP 203C	UCP 203E	17	30.2	127	95	38	13	19	15	62	56	31	12.7	M10	UC 203	P 203C	0.68
UCP 204C	UCP 204E	20	33.3	127	95	38	13	19	15	65	56	31	12.7	M10	UC 204	P 204C	0.71
UCP 205C	UCP 205E	25	36.5	140	105	38	13	16	16	70	63	34.1	14.3	M10	UC 205	P 205C	0.86
UCP 206C	UCP 206E	30	42.9	165	121	48	17	21	18	83	65	38.1	15.9	M14	UC 206	P 206C	1.4
UCP 207C	UCP 207E	35	47.6	167	127	48	17	21	19	94	70	42.9	17.5	M14	UC 207	P 207C	1.7
UCP 208C	UCP 208E	40	49.2	184	137	54	17	25	19	100	82	49.2	19	M14	UC 208	P 208C	2.2
UCP 209C	UCP 209E	45	54	190	146	54	17	22	20	108	82	49.2	19	M14	UC 209	P 209C	2.5
UCP 210C	UCP 210E	50	57.2	206	159	60	20	25	22	114	87	51.6	19	M16	UC 210	P 210C	3.0
UCP 211C	UCP 211E	55	63.5	219	171	60	20	25	22	126	88	55.6	22.2	M16	UC 211	P 211C	3.7
UCP 212C	UCP 212E	60	69.8	241	184	70	20	25	25	138	102	65.1	25.4	M16	UC 212	P 212C	5.1
UCP 213C	UCP 213E	65	76.2	265	203	70	25	29	27	150	102	65.1	25.4	M20	UC 213	P 213C	6.1

PILLOW BLOCKS

ASAHI

UCIP 200 type

Normal Duty
Set-screw Locking

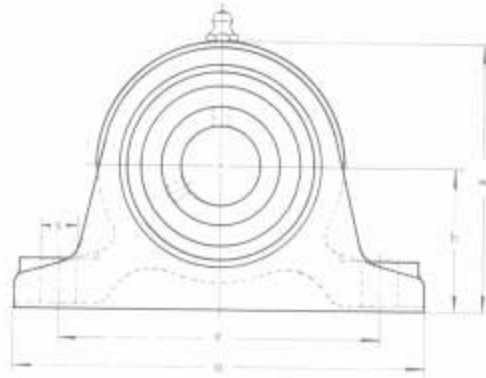

Unit No.	Shaft Diam. mm	Dimensions mm									Bolt Size mm	Bearing No.	Housing No.	Weight kg
		h	a	e	b	s	g	w	Bi	n				
UCIP 208	40	60	200	150	60	19	25	115	49.2	19	M16	UC 208	IP 208	3.6
UCIP 209	45	70	210	160	60	19	25	128	49.2	19	M16	UC 209	IP 209	3.8
UCIP 210	50	70	220	170	60	19	28	132	51.6	19	M16	UC 210	IP 210	4.4
UCIP 211	55	80	230	180	60	19	28	148	55.6	22.2	M16	UC 211	IP 211	5.5
UCIP 212	60	80	260	200	70	22	30	155	65.1	25.4	M20	UC 212	IP 212	5.9
UCIP 213	65	90	280	220	70	22	30	172	65.1	25.4	M20	UC 213	IP 213	7.5

PILLOW BLOCKS

UCIP 300 type

Heavy Duty
Set-screw Locking

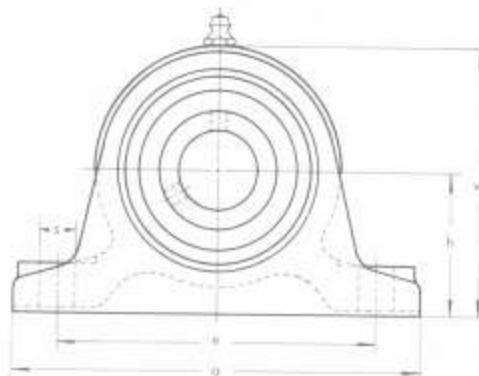

Unit No.	Shaft Diam. mm	Dimensions mm									Bolt Size mm	Bearing No.	Housing No.	Weight kg
		h	a	e	b	s	g	w	Bi	n				
UCIP 313	65	110	310	250	70	22	30	208	75	30	M20	UC 313	IP 313	12.4
UCIP 314	70	110	330	270	75	25	35	215	78	33	M22	UC 314	IP 314	14.9
UCIP 315	75	120	340	280	75	25	35	230	82	32	M22	UC 315	IP 315	16.2
UCIP 316	80	120	350	290	85	25	40	235	86	34	M22	UC 316	IP 316	20.8
UCIP 317	85	130	370	310	85	25	40	255	96	40	M22	UC 317	IP 317	23.1
UCIP 318	90	130	400	330	85	29	45	260	96	40	M24	UC 318	IP 318	25.7
UCIP 319	95	150	410	340	85	29	45	285	103	41	M24	UC 319	IP 319	29.7
UCIP 320	100	150	430	360	85	29	45	295	108	42	M24	UC 320	IP 320	33.4
UCIP 322	110	170	490	410	100	32	50	335	117	46	M27	UC 322	IP 322	50.4
UCIP 324	120	170	510	430	100	32	50	345	126	51	M27	UC 324	IP 324	56.8
UCIP 326	130	200	550	470	110	32	50	390	135	54	M27	UC 326	IP 326	73.2
UCIP 328	140	200	590	500	110	35	55	400	145	59	M30	UC 328	IP 328	83.5

PILLOW BLOCKS

UCPH 200 type

Normal Duty
Set-screw Locking

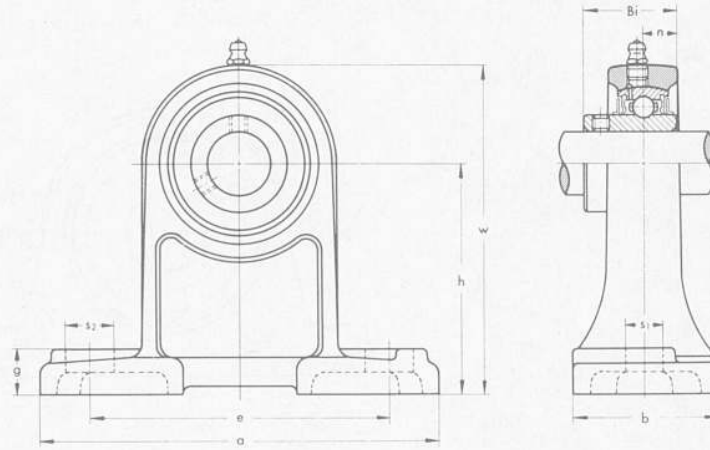

Unit No.	Shaft Diam. mm	Dimensions mm										Bolt Size mm	Bearing No.	Housing No.	Weight kg
		h	a	e	b	s ₁	s ₂	g	w	Bi	n				
UCPH 201	12	70	127	95	40	13	19	15	101	31	12.7	M10	UC 201	PH 204	1.0
UCPH 202	15	70	127	95	40	13	19	15	101	31	12.7	M10	UC 202	PH 204	0.99
UCPH 203	17	70	127	95	40	13	19	15	101	31	12.7	M10	UC 203	PH 204	0.98
UCPH 204	20	70	127	95	40	13	19	15	101	31	12.7	M10	UC 204	PH 204	0.96
UCPH 205	25	80	140	105	50	13	19	16	114	34.1	14.3	M10	UC 205	PH 205	1.2
UCPH 206	30	90	165	121	50	17	21	18	130	38.1	15.9	M14	UC 206	PH 206	1.9
UCPH 207	35	95	167	127	60	17	21	19	140	42.9	17.5	M14	UC 207	PH 207	2.4
UCPH 208	40	100	184	137	70	17	25	19	149	49.2	19	M14	UC 208	PH 208	2.8
UCPH 209	45	105	190	146	70	17	25	20	157	49.2	19	M14	UC 209	PH 209	3.2
UCPH 210	50	110	206	159	70	20	25	22	165	51.6	19	M16	UC 210	PH 210	3.6

PILLOW BLOCKS

UCPA 200 type

Normal Duty
Set-screw Locking

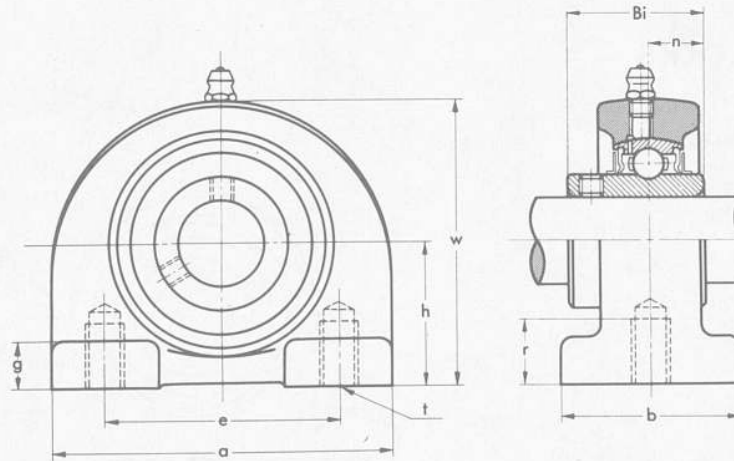

Unit No.	Shaft Diam. mm	Dimensions mm										Bolt Size mm	Bearing No.	Housing No.	Weight kg
		h	a	e	b	r	g	w	Bi	n					
UCPA 201	12	30.2	76	52	38	12	8	62	31	12.7	M10	UC 201	PA 204	0.65	
UCPA 202	15	30.2	76	52	38	12	8	62	31	12.7	M10	UC 202	PA 204	0.63	
UCPA 203	17	30.2	76	52	38	12	8	62	31	12.7	M10	UC 203	PA 204	0.62	
UCPA 204	20	30.2	76	52	38	12	8	62	31	12.7	M10	UC 204	PA 204	0.60	
UCPA 205	25	36.5	84	56	38	15	10	72	34.1	14.3	M10	UC 205	PA 205	0.81	
UCPA 206	30	42.9	94	66	48	18	10	84	38.1	15.9	M14	UC 206	PA 206	1.2	
UCPA 207	35	47.6	110	80	48	20	12	95	42.9	17.5	M14	UC 207	PA 207	1.7	
UCPA 208	40	49.2	116	84	54	20	12	100	49.2	19	M14	UC 208	PA 208	1.9	
UCPA 209	45	54.2	120	90	54	25	12	108	49.2	19	M14	UC 209	PA 209	2.2	
UCPA 210	50	57.2	130	94	60	25	14	116	51.6	19	M16	UC 210	PA 210	2.6	

PILLOW BLOCKS

* UCEP 200 type

Normal Duty
Set-screw Locking
Expansion type

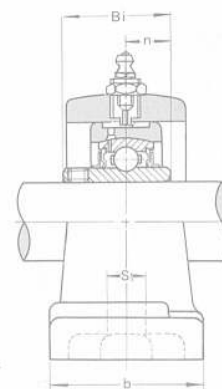
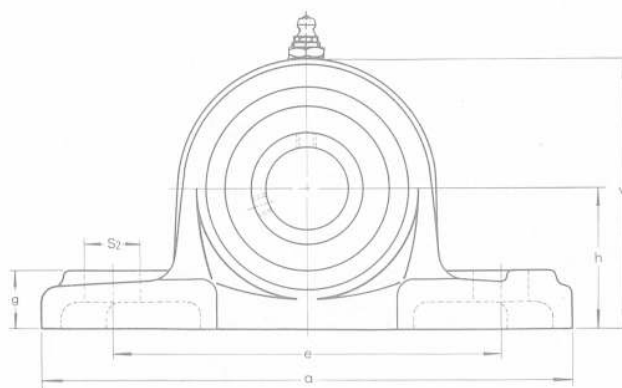

Unit No.	Shaft Diam. mm	Dimensions mm										Bolt Size mm	Bearing No.	Housing No.	Weight kg
		h	a	e	b	s ₁	s ₂	g	w	Bi	n				
UCEP 204	20	36.5	140	105	38	13	16	16	73	31	12.7	M10	UC 204	EP 204	1.1
UCEP 205	25	44.4	159	119	51	17	20	18	85	34.1	14.3	M14	UC 205	EP 205	1.5
UCEP 206	30	47.6	175	127	57	17	20	20	94	38.1	15.9	M14	UC 206	EP 206	2.0
UCEP 207	35	54	203	144	57	17	20	22	108	42.9	17.5	M14	UC 207	EP 207	2.7
UCEP 208	40	58.7	222	156	67	20	24	26	116	49.2	19	M16	UC 208	EP 209	3.5
UCEP 209	45	58.7	222	156	67	20	24	26	116	49.2	19	M16	UC 209	EP 209	3.4
UCEP 210	50	63.5	241	171	73	20	26	27	126	51.6	19	M16	UC 210	EP 210	4.1
UCEP 211	55	69.8	260	184	79	25	28	30	139	55.6	22.2	M20	UC 211	EP 211	5.6
UCEP 212	60	76.2	286	203	83	25	30	32	151	65.1	25.4	M20	UC 212	EP 212	7.1
UCEP 213	65	76.2	286	203	83	25	30	32	154	65.1	25.4	M20	UC 213	EP 213	7.0
UCEP 214	70	88.9	330	229	89	27	31	35	177	74.6	30.2	M22	UC 214	EP 215	10.8
UCEP 215	75	88.9	330	229	89	27	31	35	177	77.8	33.3	M22	UC 215	EP 215	10.9
UCEP 216	80	101.6	381	283	102	27	40	42	205	82.6	33.3	M22	UC 216	EP 217	17.1
UCEP 217	85	101.6	381	283	102	27	40	42	205	85.7	34.1	M22	UC 217	EP 217	16.4

RUBBER HOUSING PILLOW BLOCKS

* UCRP 200 type

Normal Duty
Set-screw Locking

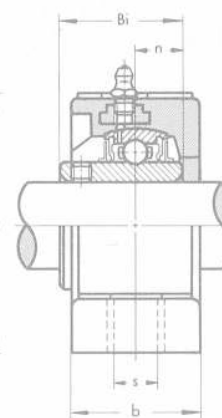
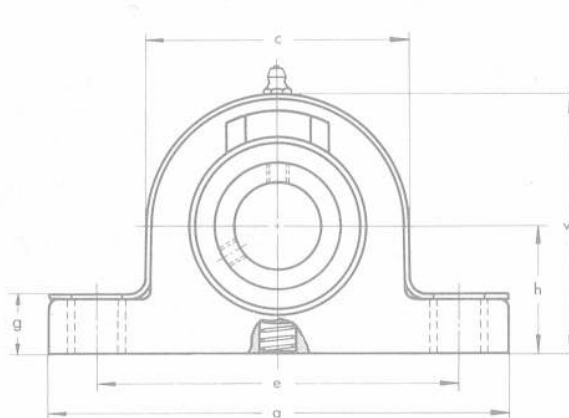

Unit No.	Shaft Diam. mm	Dimensions mm										Bolt Size mm	Bearing No.	Housing No.	Weight kg
		h	a	e	b	s	g	w	c	Bi	n				
UCRP 201	12	27	108	80	27	12.7	16	55	55	26	10	M10	UCW 201	RP 203	0.23
UCRP 202	15	27	108	80	27	12.7	16	55	55	26	10	M10	UCW 202	RP 203	0.22
UCRP 203	17	27	108	80	27	12.7	16	55	55	26	10	M10	UCW 203	RP 203	0.21
UCRP 204	20	32	118	90	27	12.7	16	65	65	31	12.7	M10	UC 204	RP 204	0.31
UCRP 205	25	33	127	98	32	12.7	16	70	70	34.1	14.3	M10	UC 205	RP 205	0.37
UCRP 206	30	40	153	115	35	16.1	20	80	80	38.1	15.9	M12	UC 206	RP 206	0.58
UCRP 207	35	45	166	127	35	16.1	20	90	90	42.9	17.5	M12	UC 207	RP 207	0.79

PILLOW BLOCKS

BP 200 type

Light Duty
Set-screw Locking

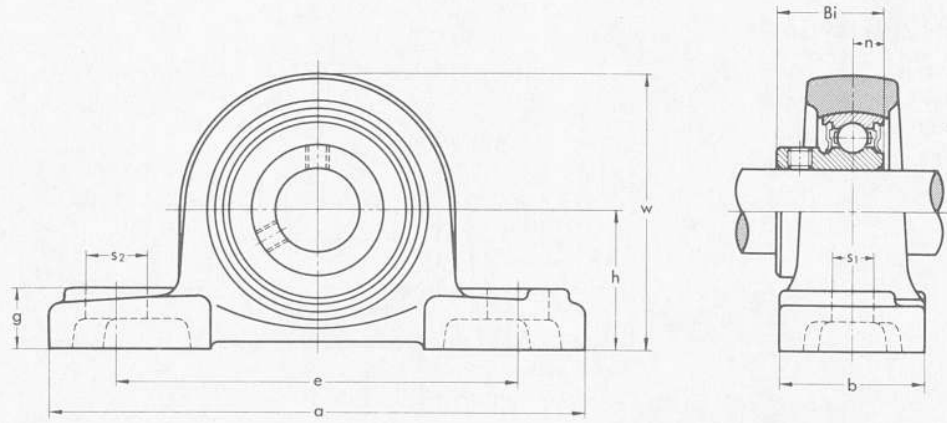

Unit No.	Shaft Diam. mm	Dimensions mm										Bolt Size mm	Bearing No.	Housing No.	Weight kg
		h	a	e	b	s ₁	s ₂	g	w	Bi	n				
BP 204	20	33.3	127	95	38	13	19	15	65	24.7	7	M10	B 4	P 204	0.61
BP 205	25	36.5	140	105	38	13	16	16	70	27	7.5	M10	B 5	P 205	0.76
BP 206	30	42.9	165	121	48	17	21	18	83	30.3	8	M14	B 6	P 206	1.2
BP 207	35	47.6	167	127	48	17	21	19	94	32.9	8.5	M14	B 7	P 207	1.6

PILLOW BLOCKS

BLLP type

Light Duty
Set-screw Locking

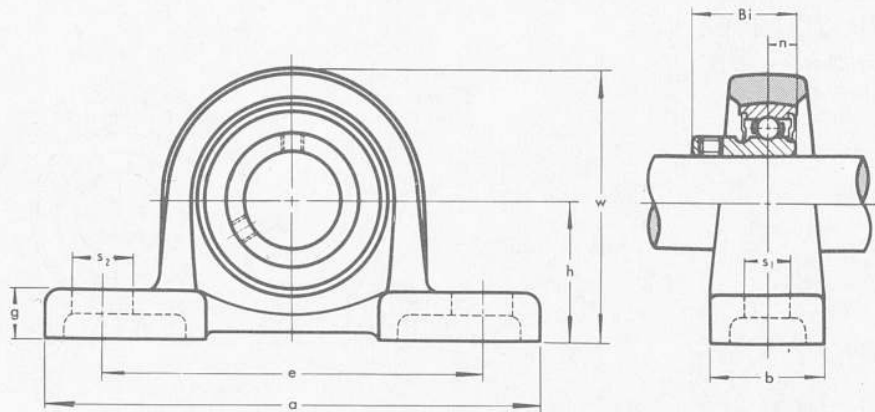

Unit No.	Shaft Diam. mm	Dimensions mm										Bolt Size mm	Bearing No.	Housing No.	Weight kg
		h	a	e	b	s ₁	s ₂	g	w	Bi	n				
BLLP 1J	12	30.2	114	87	25	12	16	12	57	22	6	M10	B 1	LLP 3J	0.39
BLLP 2J	15	30.2	114	87	25	12	16	12	57	22	6	M10	B 2	LLP 3J	0.38
BLLP 3J	17	30.2	114	87	25	12	16	12	57	22	6	M10	B 3	LLP 3J	0.36
BLLP 4J	20	33.3	125	97	27	12	16	13	64	24.7	7	M10	B 4	LLP 4J	0.48
BLLP 5J	25	36.5	130	100	29	12	16	13	70	27	7.5	M10	B 5	LLP 5J	0.59
BLLP 6J	30	42.9	156	120	33	14	21	15	83	30.3	8	M12	B 6	LLP 6J	0.70
BLLP 7J	35	47.6	165	127	35	14	21	16	93	32.9	8.5	M12	B 7	LLP 7J	0.98

PRESSED STEEL HOUSING PILLOW BLOCKS

BPP type

Light Duty
Set-screw Locking

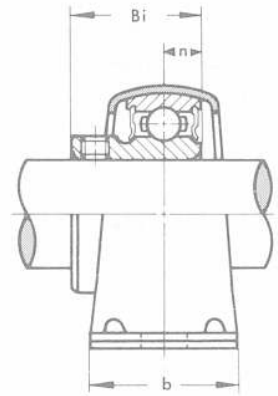
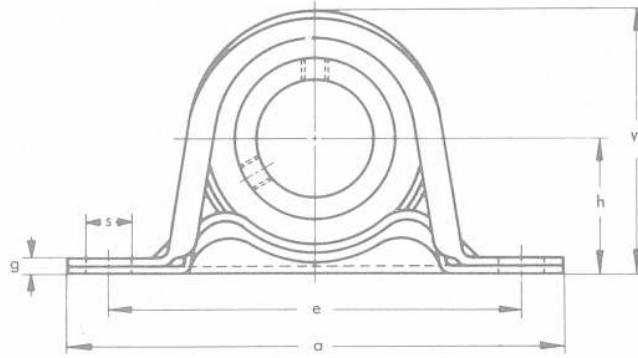

Unit No.	Shaft Diam. mm	Dimensions mm									Bolt Size mm	Bearing No.	Housing No.	Weight kg
		h	a	e	b	s	g	w	Bi	n				
BPP 1	12	22.2	86	68	25	9.5	3.2	44	22	6	M8	B 1	PP 3	0.16
BPP 2	15	22.2	86	68	25	9.5	3.2	44	22	6	M8	B 2	PP 3	0.15
BPP 3	17	22.2	86	68	25	9.5	3.2	44	22	6	M8	B 3	PP 3	0.13
BPP 4	20	25.4	98	76	32	9.5	3.2	50	24.7	7	M8	B 4	PP 4	0.21
BPP 5	25	28.6	108	86	32	11.5	4	56	27	7.5	M10	B 5	PP 5	0.29
BPP 6	30	33.3	117	95	38	11.5	4	66	30.3	8	M10	B 6	PP 6	0.42
BPP 7	35	39.7	129	106	42	11.5	4.6	78	32.9	8.5	M10	B 7	PP 7	0.61

RUBBER CUSHIONED PILLOW BLOCKS

- * BPR type
- * KHPR 200 type

Light Duty
Set-screw Locking
Eccentric Collar Locking

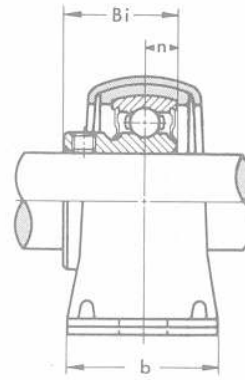
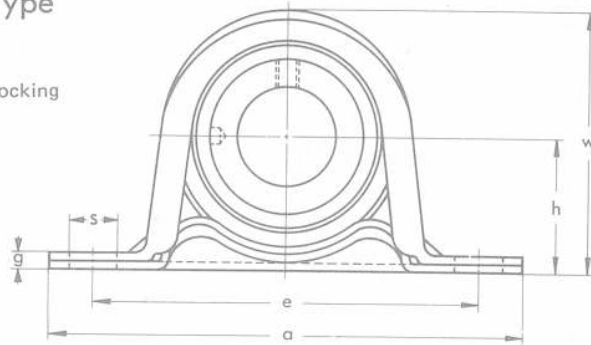

BPR type
Set-screw Locking

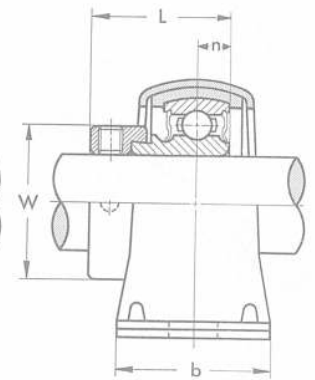

KHPR 200 type
Eccentric Collar Locking

Unit No.		Shaft Diam. mm	Dimensions mm										Bolt Size mm	Housing No.	Rubber Ring No.		Weight kg			
Complete with B type	Complete with KH 200+AE type		h	a	e	b	s	g	w	Bi	L	n			W	BPR	KHPR	BPR	KHPR	
BPR 1	KHPR 201	12	25.4	98	76	32	9.5	3.2	50	22	28.6	6	6.5	28.6	M 8	PP 4	R 4	R 4F	0.19	0.21
BPR 2	KHPR 202	15	25.4	98	76	32	9.5	3.2	50	22	28.6	6	6.5	28.6	M 8	PP 4	R 4	R 4F	0.13	0.20
BPR 3	KHPR 203	17	25.4	98	76	32	9.5	3.2	50	22	28.6	6	6.5	28.6	M 8	PP 4	R 4	R 4F	0.16	0.19
BPR 4	KHPR 204	20	28.6	108	86	32	11.5	4	56	24.7	31	7	7.5	33.3	M10	PP 5	R 5	R 5F	0.25	0.24
BPR 5	KHPR 205	25	33.3	117	95	38	11.5	4	66	27	31	7.5	7.5	38.1	M10	PP 6	R 6	R 6	0.33	0.35
BPR 6	KHPR 206	30	39.7	129	106	42	11.5	4.6	78	30.3	35.7	8	9	44.5	M10	PP 7	R 7	R 7F	0.48	0.53

CAST STEEL HOUSING PILLOW BLOCKS

* UCPK 200 type

Normal Duty
Set-screw Locking

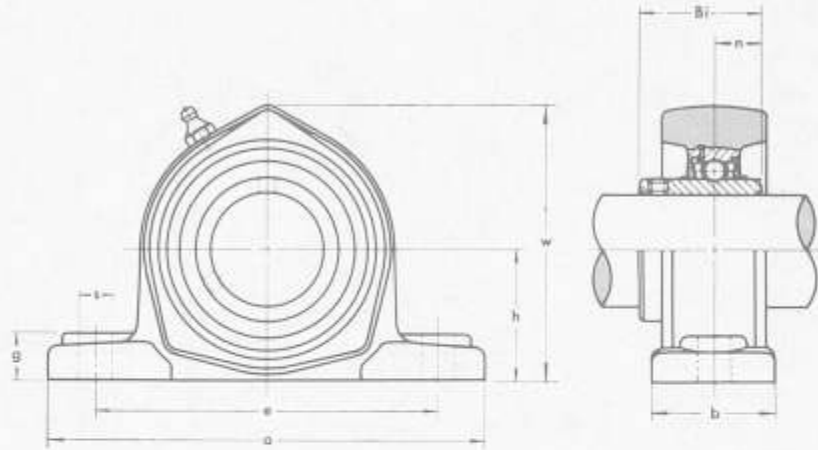

Unit No.	Shaft Diam. mm	Dimensions mm										Bolt Size mm	Bearing No.	Housing No.	Weight kg
		h	a	e	b	s	g	w	Bi	n					
UCPK 212	60	69.8	233	184	65	19	25	145	65.1	25.4	M16	UC 212	PK 212	5.7	
UCPK 213	65	76.2	258	203	70	24	27	156	65.1	25.4	M20	UC 213	PK 213	6.7	
UCPK 214	70	79.4	266	210	72	24	27	162	74.6	30.2	M20	UC 214	PK 214	7.6	
UCPK 215	75	82.6	272	217	74	24	28	167	77.8	33.3	M20	UC 215	PK 215	8.1	
UCPK 216	80	88.9	288	232	75	24	30	188	82.6	33.3	M20	UC 216	PK 216	10.4	
UCPK 217	85	95.2	303	247	80	24	32	199	85.7	34.1	M20	UC 217	PK 217	12.2	
UCPK 218	90	101.6	322	262	85	26	34	211	96	39.7	M22	UC 218	PK 218	15.2	

MALLEABLE HOUSING PILLOW BLOCKS

* BPW 200 type * KHPW 200 type

Light Duty

OBsolete

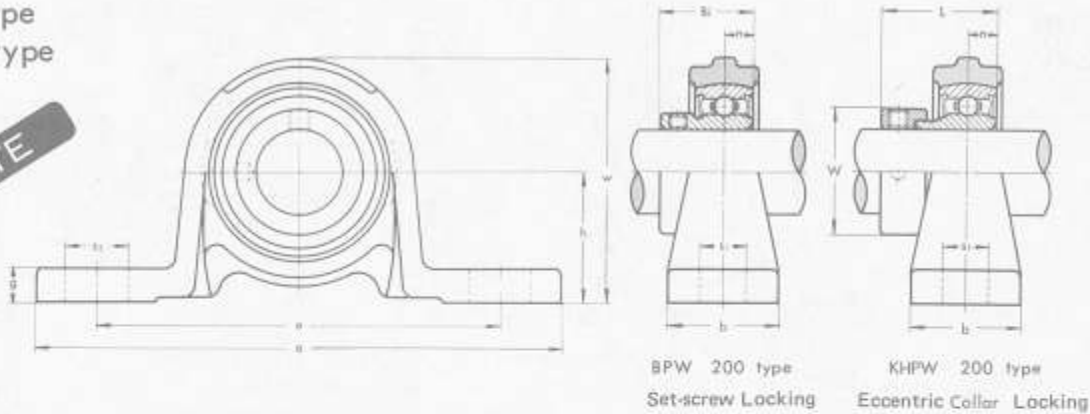

BPW 200 type Set-screw Locking
KHPW 200 type Eccentric Collar Locking

Unit No.		Shaft Diam. mm	Dimensions mm										Bolt Size mm	Housing No.	Weight kg				
Complete with B type	Complete with KH 200 + AE type		h	a	e	b	s ₁	s ₂	g	w	Bi	L			n	W	BPW	KHPW	
BPW 201	KHPW 201	12	30.2	114	87	25	11	16	7	55	22	28.6	6	6.5	28.6	M10	PW203K	0.27	0.31
BPW 202	KHPW 202	15	30.2	114	87	25	11	16	7	55	22	28.6	6	6.5	28.6	M10	PW203K	0.26	0.30
BPW 203	KHPW 203	17	30.2	114	87	25	11	16	7	55	22	28.6	6	6.5	28.6	M10	PW203K	0.24	0.29
BPW 204	KHPW 204	20	33.3	125	97	27	11	16	8	62	24.7	31	7	7.5	33.3	M10	PW204K	0.37	0.37
BPW 205	KHPW 205	25	36.5	130	100	29	11	16	9	69	27	31	7.5	7.5	38.1	M10	PW205K	0.46	0.48
BPW 206	KHPW 206	30	42.9	156	120	33	14	21	10	81	30.3	35.7	8	9	44.5	M12	PW206K	0.75	0.81
BPW 207	KHPW 207	35	47.6	165	127	35	14	21	10	91	32.9	38.9	8.5	9.5	55.6	M12	PW207K	0.98	1.1
—	KHPW 208	40	50.8	181	140	37	14	22	11	99	—	43.7	—	11	60.3	M12	PW208K	—	1.4
—	KHPW 209	45	54	190	146	38	14	24	12	106	—	43.7	—	11	63.5	M12	PW209K	—	1.5
—	KHPW 210	50	57.2	202	157	40	14	24	13	112	—	43.7	—	11	69.9	M12	PW210K	—	1.7

SQUARE FLANGE UNITS

UCF 200 type

Normal Duty
Set-screw Locking

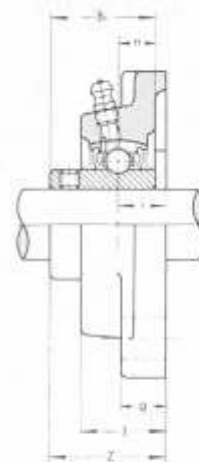
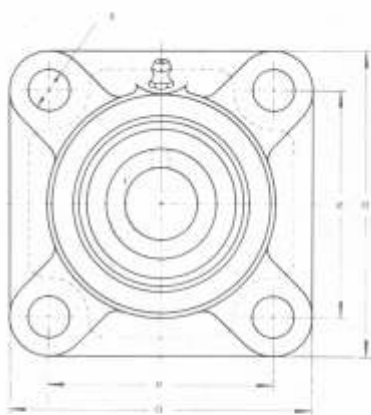

Unit No.	Shaft Diam. mm	Dimensions mm									Bolt Size mm	Bearing No.	Housing No.	Weight kg
		a	e	l	g	l	s	Z	Bi	n				
UCF 201	12	86	64	15	12	25.5	12	33.3	31	12.7	M10	UC 201	F 204	0.64
UCF 202	15	86	64	15	12	25.5	12	33.3	31	12.7	M10	UC 202	F 204	0.62
UCF 203	17	86	64	15	12	25.5	12	33.3	31	12.7	M10	UC 203	F 204	0.61
UCF 204	20	86	64	15	12	25.5	12	33.3	31	12.7	M10	UC 204	F 204	0.59
UCF 205	25	95	70	16	14	27	12	35.7	34.1	14.3	M10	UC 205	F 205	0.82
UCF 206	30	108	83	18	14	31	12	40.2	38.1	15.9	M10	UC 206	F 206	1.1
UCF 207	35	117	92	19	16	34	14	44.4	42.9	17.5	M12	UC 207	F 207	1.3
UCF 208	40	130	102	21	16	36	16	51.2	49.2	19	M14	UC 208	F 208	2.0
UCF 209	45	137	105	22	18	38	16	52.2	49.2	19	M14	UC 209	F 209	2.4
UCF 210	50	143	111	22	18	40	16	54.6	51.6	19	M14	UC 210	F 210	2.5
UCF 211	55	162	130	25	20	43	19	58.4	55.6	22.2	M16	UC 211	F 211	3.4
UCF 212	60	175	143	29	20	48	19	68.7	65.1	25.4	M16	UC 212	F 212	4.6
UCF 213	65	187	149	30	20	50	19	69.7	65.1	25.4	M16	UC 213	F 213	5.5
UCF 214	70	193	152	31	24	54	19	75.4	74.6	30.2	M16	UC 214	F 214	6.1
UCF 215	75	200	159	34	24	56	19	78.5	77.8	33.3	M16	UC 215	F 215	6.9
UCF 216	80	208	165	34	24	58	23	83.3	82.6	33.3	M20	UC 216	F 216	7.8
UCF 217	85	220	175	36	26	63	23	87.6	85.7	34.1	M20	UC 217	F 217	9.3
UCF 218	90	235	187	40	26	68	23	96.3	96	39.7	M20	UC 218	F 218	11.3

SQUARE FLANGE UNITS

*UCLF 200 type

Normal Duty
Set-screw Locking

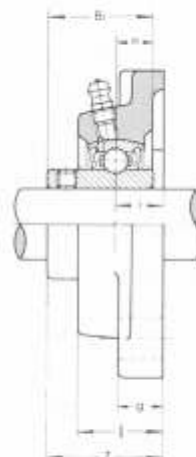
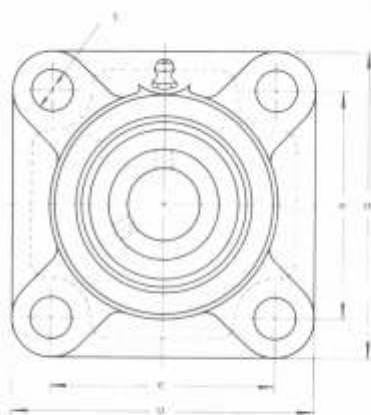

Unit No.	Shaft Diam. mm	Dimensions mm									Bolt Size mm	Bearing No.	Housing No.	Weight kg
		a	e	l	g	l	s	Z	Bi	n				
UCLF 201	12	76	54	16.7	10	28	10.5	32.7	26	10	M 8	UCW 201	LF 203	0.52
UCLF 202	15	76	54	16.7	10	28	10.5	32.7	26	10	M 8	UCW 202	LF 203	0.51
UCLF 203	17	76	54	16.7	10	28	10.5	32.7	26	10	M 8	UCW 203	LF 203	0.50
UCLF 204	20	86	63.5	20.6	10	33	10.5	38.9	31	12.7	M 8	UC 204	LF 204	0.68
UCLF 205	25	95	69.8	21	11	35	12.5	40.7	34.1	14.3	M10	UC 205	LF 205	0.85
UCLF 206	30	108	82.6	22.6	13	37	12.5	44.8	38.1	15.9	M10	UC 206	LF 206	1.2
UCLF 207	35	117	92.1	22.2	14	38	14	47.6	42.9	17.5	M12	UC 207	LF 207	1.6
UCLF 208	40	130	101.6	24.6	16	41	14	54.8	49.2	19	M12	UC 208	LF 208	2.1
UCLF 209	45	137	104.8	24.6	16	42	16	54.8	49.2	19	M14	UC 209	LF 209	2.4
UCLF 210	50	143	111.1	27.8	16	46	16	60.4	51.6	19	M14	UC 210	LF 210	2.6
UCLF 211	55	162	130.2	31	17	50	18	64.4	55.6	22.2	M16	UC 211	LF 211	3.6
UCLF 212	60	175	142.9	34.1	17	55	18	73.8	65.1	25.4	M16	UC 212	LF 212	4.7
UCLF 213	65	175	142.9	34.1	17	55	18	73.8	65.1	25.4	M16	UC 213	LF 213	4.8

SQUARE FLANGE UNITS

UCF X00 type

Medium Duty
Set-screw Locking

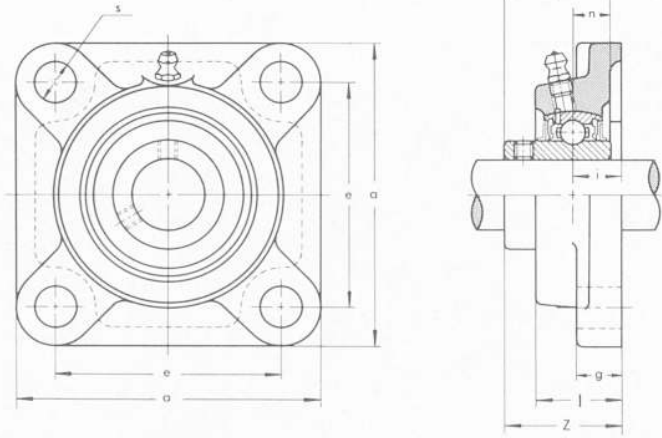

Unit No.	Shaft Diam. mm	Dimensions mm									Bolt Size mm	Bearing No.	Housing No.	Weight kg
		a	e	i	g	l	s	Z	Bi	n				
UCF X05	25	108	83	18	13	30	12	40.2	38.1	15.9	M10	UC X05	F X05	1.1
UCF X06	30	117	92	19	14	34	16	44.4	42.9	17.5	M14	UC X06	F X06	1.3
UCF X07	35	130	102	21	14	38	16	51.2	49.2	19	M14	UC X07	F X07	1.8
UCF X08	40	137	105	22	14	40	19	52.2	49.2	19	M16	UC X08	F X08	1.8
UCF X09	45	143	111	23	14	40	19	55.6	51.6	19	M16	UC X09	F X09	2.4
UCF X10	50	162	130	26	20	44	19	59.4	55.6	22.2	M16	UC X10	F X10	3.6
UCF X11	55	175	143	29	20	49	19	68.7	65.1	25.4	M16	UC X11	F X11	4.5
UCF X12	60	187	149	34	21	59	19	73.7	65.1	25.4	M16	UC X12	F X12	5.3
UCF X13	65	187	149	34	21	59	19	78.4	74.6	30.2	M16	UC X13	F X13	5.5
UCF X14	70	197	152	37	24	60	23	81.5	77.8	33.3	M20	UC X14	F X14	7.7
UCF X15	75	197	152	40	24	68	23	89.3	82.6	33.3	M20	UC X15	F X15	7.7
UCF X16	80	214	171	40	24	70	23	91.6	85.7	34.1	M20	UC X16	F X16	10.2
UCF X17	85	214	171	40	24	70	23	96.3	96	39.7	M20	UC X17	F X17	10.2
UCF X18	90	214	171	45	24	76	23	106.1	104	42.9	M20	UC X18	F X18	10.6
UCF X20	100	268	211	59	31	97	31	127.3	117.5	49.2	M27	UC X20	F X20	16.8

SQUARE FLANGE UNITS

UCF 300 type

Heavy Duty
Set-screw Locking

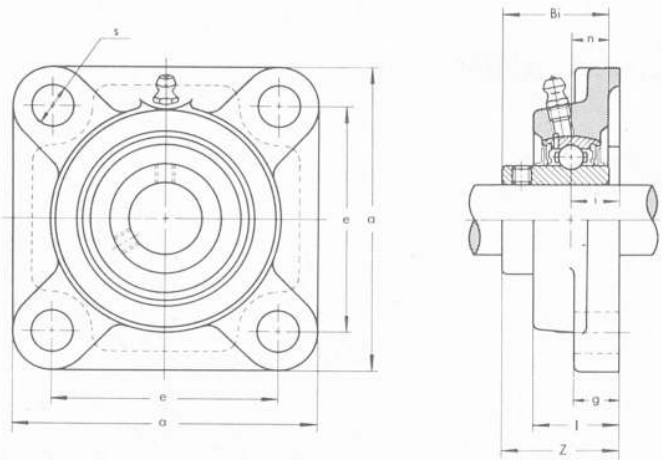

Unit No.	Shaft Diam. mm	Dimensions mm									Bolt Size mm	Bearing No.	Housing No.	Weight kg
		a	e	i	g	l	s	Z	Bi	n				
UCF 305	25	110	80	16	13	29	16	39	38	15	M14	UC 305	F 305	1.2
UCF 306	30	125	95	18	15	32	16	44	43	17	M14	UC 306	F 306	1.7
UCF 307	35	135	100	20	16	36	19	49	48	19	M16	UC 307	F 307	2.1
UCF 308	40	150	112	23	17	40	19	56	52	19	M16	UC 308	F 308	2.9
UCF 309	45	160	125	25	18	44	19	60	57	22	M16	UC 309	F 309	3.6
UCF 310	50	175	132	28	19	48	23	67	61	22	M20	UC 310	F 310	4.7
UCF 311	55	185	140	30	20	52	23	71	66	25	M20	UC 311	F 311	5.7
UCF 312	60	195	150	33	22	56	23	78	71	26	M20	UC 312	F 312	6.8
UCF 313	65	208	166	33	22	58	23	78	75	30	M20	UC 313	F 313	7.8
UCF 314	70	226	178	36	25	61	25	81	78	33	M22	UC 314	F 314	9.6
UCF 315	75	236	184	39	25	66	25	89	82	32	M22	UC 315	F 315	11.7
UCF 316	80	250	196	38	27	68	31	90	86	34	M27	UC 316	F 316	13.7
UCF 317	85	260	204	44	27	74	31	100	96	40	M27	UC 317	F 317	15.2
UCF 318	90	280	216	44	30	76	35	100	96	40	M30	UC 318	F 318	18.8
UCF 319	95	290	228	59	30	94	35	121	103	41	M30	UC 319	F 319	20.7
UCF 320	100	310	242	59	32	94	38	125	108	42	M33	UC 320	F 320	24.8
UCF 321	105	310	242	59	32	94	38	127	112	44	M33	UC 321	F 321	25.6
UCF 322	110	340	266	60	35	96	41	131	117	46	M36	UC 322	F 322	34.7
UCF 324	120	370	290	65	40	110	41	140	126	51	M36	UC 324	F 324	47.2
UCF 326	130	410	320	65	45	115	41	146	135	54	M36	UC 326	F 326	62.7
UCF 328	140	450	350	75	55	125	41	161	145	59	M36	UC 328	F 328	87.0

SQUARE FLANGE UNITS

UKF 200+H type

Normal Duty
Adapter Sleeve Locking

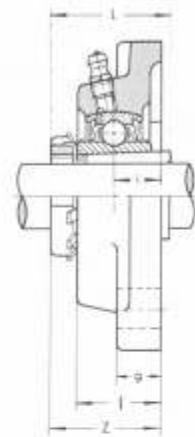
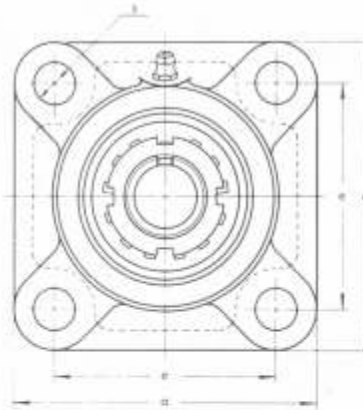

Unit No.	Shaft Diam. mm	Dimensions mm								Bolt Size mm	Bearing No.	Housing No.	Weight kg
		a	e	i	g	l	s	Z	L				
UKF 205+H2305	20	95	70	16	14	27	12	35.5	35	M10	UK 205+H2305	F 205	0.87
UKF 206+H2306	25	108	83	18	14	31	12	39	38	M10	UK 206+H2306	F 206	1.2
UKF 207+H2307	30	117	92	19	16	34	14	41.5	43	M12	UK 207+H2307	F 207	1.5
UKF 208+H2308	35	130	102	21	16	36	16	45.5	46	M14	UK 208+H2308	F 208	2.1
UKF 209+H2309	40	137	105	22	18	38	16	48	50	M14	UK 209+H2309	F 209	2.5
UKF 210+H2310	45	143	111	22	18	40	16	49.5	55	M14	UK 210+H2310	F 210	2.7
UKF 211+H2311	50	162	130	25	20	43	19	53.5	59	M16	UK 211+H2311	F 211	3.6
UKF 212+H2312	55	175	143	29	20	48	19	60	62	M16	UK 212+H2312	F 212	4.6
UKF 213+H2313	60	187	149	30	20	50	19	63	65	M16	UK 213+H2313	F 213	5.7
UKF 215+H2315	65	200	159	34	24	56	19	69.5	73	M16	UK 215+H2315	F 215	7.3
UKF 216+H2316	70	208	165	34	24	58	23	73	78	M20	UK 216+H2316	F 216	8.2
UKF 217+H2317	75	220	175	36	26	63	23	77	82	M20	UK 217+H2317	F 217	9.8
UKF 218+H2318	80	235	187	40	26	68	23	82.5	86	M20	UK 218+H2318	F 218	11.7

SQUARE FLANGE UNITS

UKF X00+H type

Medium Duty
Adapter Sleeve Locking

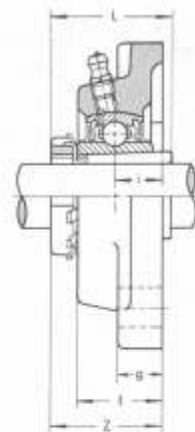
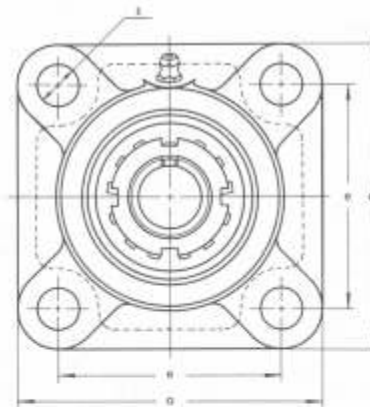

Unit No.	Shaft Diam. mm	Dimensions mm								Bolt Size mm	Bearing No.	Housing No.	Weight kg
		a	e	i	g	l	s	Z	L				
UKF X05+H2305	20	108	83	18	13	30	12	39	35	M10	UK X05+H2305	F X05	1.1
UKF X06+H2306	25	117	92	19	14	34	16	40.5	38	M14	UK X06+H2306	F X06	1.4
UKF X07+H2307	30	130	102	21	14	38	16	44.5	43	M14	UK X07+H2307	F X07	1.8
UKF X08+H2308	35	137	105	22	14	40	19	47	46	M16	UK X08+H2308	F X08	1.8
UKF X09+H2309	40	143	111	23	14	40	19	49.5	50	M16	UK X09+H2309	F X09	2.4
UKF X10+H2310	45	162	130	26	20	44	19	54.5	55	M16	UK X10+H2310	F X10	3.6
UKF X11+H2311	50	175	143	29	20	49	19	59	59	M16	UK X11+H2311	F X11	4.3
UKF X12+H2312	55	187	149	34	21	59	19	66	62	M16	UK X12+H2312	F X12	5.3
UKF X13+H2313	60	187	149	34	21	59	19	68	65	M16	UK X13+H2313	F X13	5.2
UKF X15+H2315	65	197	152	40	24	68	23	77	73	M20	UK X15+H2315	F X15	7.7
UKF X16+H2316	70	214	171	40	24	70	23	80	78	M20	UK X16+H2316	F X16	10.2
UKF X17+H2317	75	214	171	40	24	70	23	82.5	82	M20	UK X17+H2317	F X17	10.1
UKF X18+H2318	80	214	171	45	24	76	23	89	86	M20	UK X18+H2318	F X18	10.2
UKF X20+H2320	90	268	211	59	31	97	31	108	97	M27	UK X20+H2320	F X20	15.9

SQUARE FLANGE UNITS

UKF 300+H type

Heavy Duty
Adapter Sleeve Locking

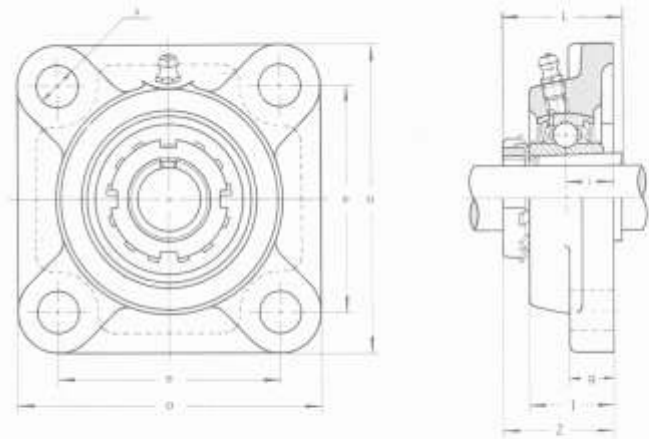

Unit No.	Shaft Diam. mm	Dimensions mm									Bolt Size mm	Bearing No.	Housing No.	Weight kg
		a	e	i	g	l	s	Z	L					
UKF 305+H2305	20	110	80	16	13	29	16	37	35	M14	UK 305+H2305	F 305	1.2	
UKF 306+H2306	25	125	95	18	15	32	16	40.5	38	M14	UK 306+H2306	F 306	1.7	
UKF 307+H2307	30	135	100	20	16	36	19	44.5	43	M16	UK 307+H2307	F 307	2.1	
UKF 308+H2308	35	150	112	23	17	40	19	50	46	M16	UK 308+H2308	F 308	3.0	
UKF 309+H2309	40	160	125	25	18	44	19	54.5	50	M16	UK 309+H2309	F 309	3.6	
UKF 310+H2310	45	175	132	28	19	48	23	60	55	M20	UK 310+H2310	F 310	4.8	
UKF 311+H2311	50	185	140	30	20	52	23	63.5	59	M20	UK 311+H2311	F 311	5.7	
UKF 312+H2312	55	195	150	33	22	56	23	69	62	M20	UK 312+H2312	F 312	6.7	
UKF 313+H2313	60	208	166	33	22	58	23	71	65	M20	UK 313+H2313	F 313	7.7	
UKF 315+H2315	65	236	184	39	25	66	25	81	73	M22	UK 315+H2315	F 315	11.8	
UKF 316+H2316	70	250	196	38	27	68	31	83.5	78	M27	UK 316+H2316	F 316	13.9	
UKF 317+H2317	75	260	204	44	27	74	31	92	82	M27	UK 317+H2317	F 317	15.1	
UKF 318+H2318	80	280	216	44	30	76	35	93.5	86	M30	UK 318+H2318	F 318	19.0	
UKF 319+H2319	85	290	228	59	30	94	35	111	90	M30	UK 319+H2319	F 319	20.8	
UKF 320+H2320	90	310	242	59	32	94	38	115	97	M33	UK 320+H2320	F 320	24.8	
UKF 322+H2322	100	340	266	60	35	96	41	121	105	M36	UK 322+H2322	F 322	34.8	
UKF 324+H2324	110	370	290	65	40	110	41	130	112	M36	UK 324+H2324	F 324	46.7	
UKF 326+H2326	115	410	320	65	45	115	41	134	121	M36	UK 326+H2326	F 326	63.0	
UKF 328+H2328	125	450	350	75	55	125	41	148	131	M36	UK 328+H2328	F 328	87.3	

SQUARE FLANGE UNITS

* UDF 200 type

Normal Duty
Eccentric Collar Locking

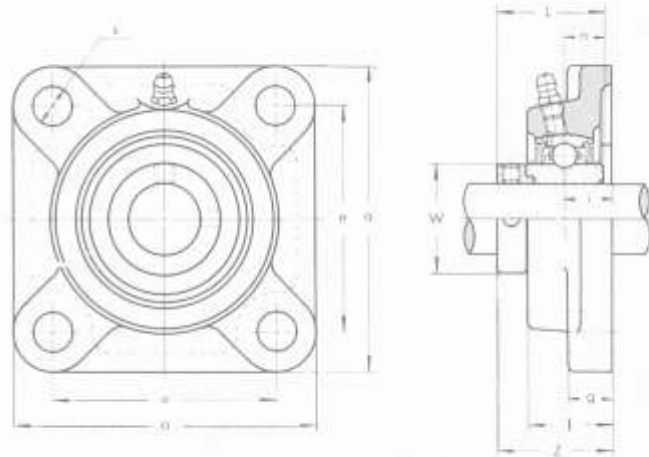

Unit No.	Shaft Diam. mm	Dimensions mm										Bolt Size mm	Bearing No.	Housing No.	Weight kg
		a	e	i	g	l	s	Z	L	n	W				
UDF 204	20	86	64	15	12	25.5	12	34.5	31	11.5	29	M10	UD 204 +EE	F 204	0.59
UDF 205	25	95	70	16	14	27	12	36.5	32	11.5	34	M10	UD 205 +EE	F 205	0.81
UDF 206	30	108	83	18	14	31	12	41	36	13	40	M10	UD 206 +EE	F 206	1.1
UDF 207	35	117	92	19	16	34	14	43.5	38	13.5	48	M12	UD 207 +EE	F 207	1.4
UDF 208	40	130	102	21	16	36	16	46.5	40	14.5	53	M14	UD 208 +EE	F 208	2.0
UDF 209	45	137	105	22	18	38	16	49	42	15	57	M14	UD 209 +EE	F 209	2.3
UDF 210	50	143	111	22	18	40	16	49.5	43	15.5	63	M14	UD 210 +EE	F 210	2.4

**SQUARE FLANGE UNITS
WITH CAST IRON COVERS**

CUCF 200C(CE) type

Normal Duty
Set-screw Locking

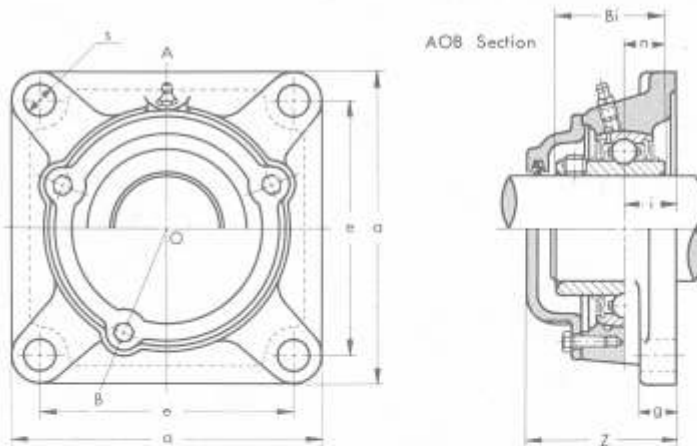

Unit No.		Shaft Diam. mm	Dimensions mm								Bolt Size mm	Bearing No.	Housing No.	Weight kg
Open Cover	Closed Cover		a	e	i	g	s	Z	Bi	n				
CUCF 201C	CUCF 201CE	12	86	64	15	12	12	46	31	12.7	M10	UC 201	CF 204	1.0
CUCF 202C	CUCF 202CE	15	86	64	15	12	12	46	31	12.7	M10	UC 202	CF 204	1.0
CUCF 203C	CUCF 203CE	17	86	64	15	12	12	46	31	12.7	M10	UC 203	CF 204	1.0
CUCF 204C	CUCF 204CE	20	86	64	15	12	12	46	31	12.7	M10	UC 204	CF 204	1.0
CUCF 205C	CUCF 205CE	25	95	70	16	14	12	51	34.1	14.3	M10	UC 205	CF 205	1.2
CUCF 206C	CUCF 206CE	30	108	83	18	14	12	55	38.1	15.9	M10	UC 206	CF 206	1.6
CUCF 207C	CUCF 207CE	35	117	92	19	16	14	59	42.9	17.5	M12	UC 207	CF 207	2.1
CUCF 208C	CUCF 208CE	40	130	102	21	16	16	66	49.2	19	M14	UC 208	CF 208	2.7
CUCF 209C	CUCF 209CE	45	137	105	22	18	16	67	49.2	19	M14	UC 209	CF 209	3.1
CUCF 210C	CUCF 210CE	50	143	111	22	18	16	71	51.6	19	M14	UC 210	CF 210	3.6
CUCF 211C	CUCF 211CE	55	162	130	25	20	19	75	55.6	22.2	M16	UC 211	CF 211	4.6
CUCF 212C	CUCF 212CE	60	175	143	29	20	19	86	65.1	25.4	M16	UC 212	CF 212	5.9
CUCF 213C	CUCF 213CE	65	187	149	30	20	19	89	65.1	25.4	M16	UC 213	CF 213	7.1
CUCF 214C	CUCF 214CE	70	193	152	31	24	19	98	74.6	30.2	M16	UC 214	CF 214	7.8
CUCF 215C	CUCF 215CE	75	200	159	34	24	19	102	77.8	33.3	M16	UC 215	CF 215	8.6
CUCF 216C	CUCF 216CE	80	208	165	34	24	23	107	82.6	33.3	M20	UC 216	CF 216	10.0
CUCF 217C	CUCF 217CE	85	220	175	36	26	23	111	85.7	34.1	M20	UC 217	CF 217	11.8
CUCF 218C	CUCF 218CE	90	235	187	40	26	23	122	96	39.7	M20	UC 218	CF 218	14.9

**SQUARE FLANGE UNITS
WITH PRESSED STEEL COVERS**

UCF 200C(E) type

Normal Duty
Set-screw Locking

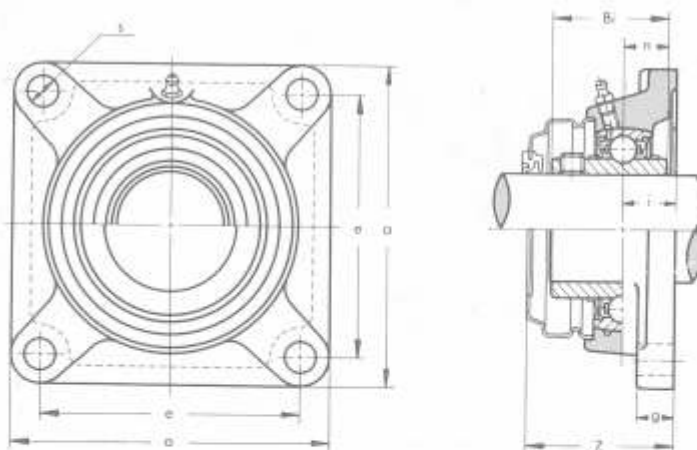

Unit No.		Shaft Diam. mm	Dimensions mm								Bolt Size mm	Bearing No.	Housing No.	Weight kg
Open Cover	Closed Cover		a	e	i	g	s	Z	Bi	n				
UCF 201C	UCF 201E	12	86	64	15	12	12	43	31	12.7	M10	UC 201	F 204C	0.67
UCF 202C	UCF 202E	15	86	64	15	12	12	43	31	12.7	M10	UC 202	F 204C	0.65
UCF 203C	UCF 203E	17	86	64	15	12	12	43	31	12.7	M10	UC 203	F 204C	0.64
UCF 204C	UCF 204E	20	86	64	15	12	12	43	31	12.7	M10	UC 204	F 204C	0.62
UCF 205C	UCF 205E	25	95	70	16	14	12	48	34.1	14.3	M10	UC 205	F 205C	0.86
UCF 206C	UCF 206E	30	108	83	18	14	12	51	38.1	15.9	M10	UC 206	F 206C	1.2
UCF 207C	UCF 207E	35	117	92	19	16	14	54	42.9	17.5	M12	UC 207	F 207C	1.6
UCF 208C	UCF 208E	40	130	102	21	16	16	62	49.2	19	M14	UC 208	F 208C	2.1
UCF 209C	UCF 209E	45	137	105	22	18	16	63	49.2	19	M14	UC 209	F 209C	2.5
UCF 210C	UCF 210E	50	143	111	22	18	16	66	51.6	19	M14	UC 210	F 210C	2.6
UCF 211C	UCF 211E	55	162	130	25	20	19	69	55.6	22.2	M16	UC 211	F 211C	3.6
UCF 212C	UCF 212E	60	175	143	29	20	19	80	65.1	25.4	M16	UC 212	F 212C	4.8
UCF 213C	UCF 213E	65	187	149	30	20	19	81	65.1	25.4	M16	UC 213	F 213C	5.8

SQUARE FLANGE UNITS

BF 200 type

Light Duty
Set-screw Locking

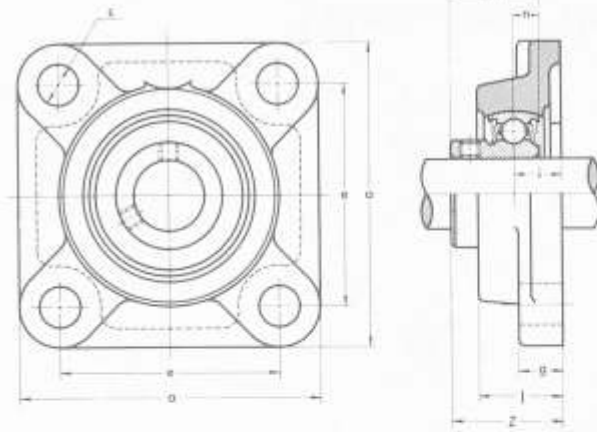

Unit No.	Shaft Diam. mm	Dimensions mm									Bolt Size mm	Bearing No.	Housing No.	Weight kg
		a	e	l	g	l	s	Z	Bi	n				
BF 204	20	86	64	15	12	25.5	12	32.7	24.7	7	M10	B 4	F 204	0.55
BF 205	25	95	70	16	14	27	12	35.5	27	7.5	M10	B 5	F 205	0.79
BF 206	30	108	83	18	14	31	12	40.3	30.3	8	M10	B 6	F 206	1.1
BF 207	35	117	92	19	16	34	14	43.4	32.9	8.5	M12	B 7	F 207	1.5

PRESSED STEEL HOUSING FLANGE UNITS

BPF type BPFT type

Light Duty
Set-screw Locking

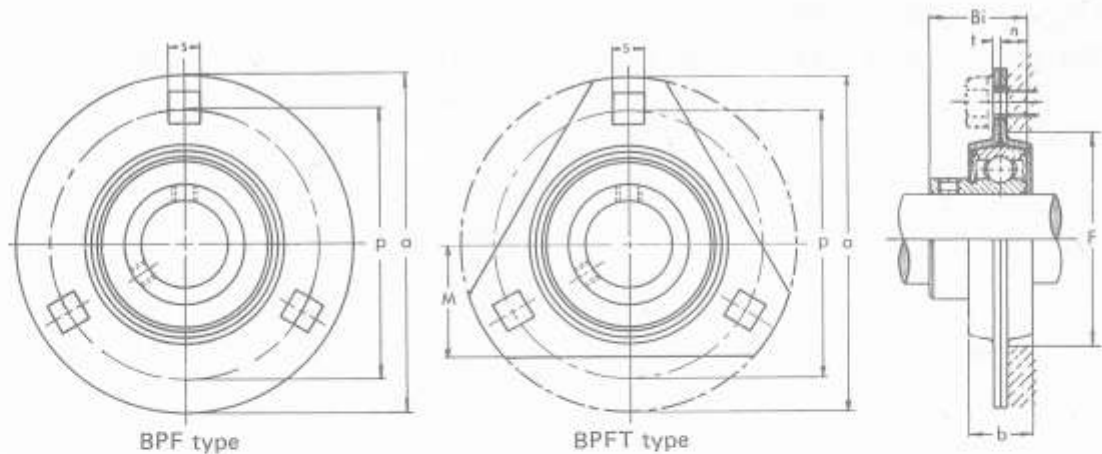

Unit No.	Shaft Diam. mm	Dimensions mm										Bolt Size mm	Bearing No.	Housing No.		Weight kg
		a	p	t	b	s	F (Min.)	M	Bi	n						
BPF 1	BPFT 1	12	81	63.5	2	14	7	49	29	22	6	M6	B 1	PF3	PFT 3	0.21
BPF 2	BPFT 2	15	81	63.5	2	14	7	49	29	22	6	M6	B 2	PF3	PFT 3	0.20
BPF 3	BPFT 3	17	81	63.5	2	14	7	49	29	22	6	M6	B 3	PF3	PFT 3	0.18
BPF 4	BPFT 4	20	90	71.5	2	16	9	56	33	24.7	7	M8	B 4	PF4	PFT 4	0.25
BPF 5	BPFT 5	25	95	76	2	18	9	60	35	27	7.5	M8	B 5	PF5	PFT 5	0.35
BPF 6	BPFT 6	30	113	90.5	2.6	18	11	71	38	30.3	8	M10	B 6	PF6	PFT 6	0.54
BPF 7	BPFT 7	35	120	100	2.6	20	11	81	45	32.9	8.5	M10	B 7	PF7	PFT 7	0.71

FLANGE CARTRIDGE UNITS

UCFC 200 type

Normal Duty
Set-screw Locking

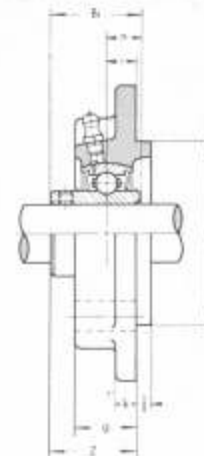
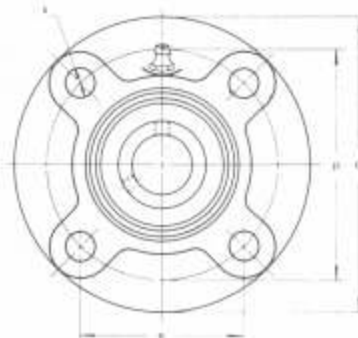

Unit No.	Shaft Diam. mm	Dimensions mm													Bolt Size mm	Bearing No.	Housing No.	Weight kg
		a	p	e	i	s	j	k	g	f	Z	Bi	n					
UCFC 201	12	100	78	55.1	10	12	5	7	20.5	62	28.3	31	12.7	M10	UC 201	FC 204	0.89	
UCFC 202	15	100	78	55.1	10	12	5	7	20.5	62	28.3	31	12.7	M10	UC 202	FC 204	0.87	
UCFC 203	17	100	78	55.1	10	12	5	7	20.5	62	28.3	31	12.7	M10	UC 203	FC 204	0.86	
UCFC 204	20	100	78	55.1	10	12	5	7	20.5	62	28.3	31	12.7	M10	UC 204	FC 204	0.84	
UCFC 205	25	115	90	63.6	10	12	6	7	21	70	29.7	34.1	14.3	M10	UC 205	FC 205	1.1	
UCFC 206	30	125	100	70.7	10	12	8	8	23	80	32.2	38.1	15.9	M10	UC 206	FC 206	1.5	
UCFC 207	35	135	110	77.8	11	14	8	9	26	90	36.4	42.9	17.5	M12	UC 207	FC 207	1.7	
UCFC 208	40	145	120	84.8	11	14	10	9	26	100	41.2	49.2	19	M12	UC 208	FC 208	2.1	
UCFC 209	45	160	132	93.3	10	16	12	14	26	105	40.2	49.2	19	M14	UC 209	FC 209	3.0	
UCFC 210	50	165	138	97.6	10	16	12	14	28	110	42.6	51.6	19	M14	UC 210	FC 210	3.1	
UCFC 211	55	185	150	106.1	13	19	12	15	31	125	46.4	55.6	22.2	M16	UC 211	FC 211	3.9	
UCFC 212	60	195	160	113.1	17	19	12	15	36	135	56.7	65.1	25.4	M16	UC 212	FC 212	4.4	
UCFC 213	65	205	170	120.2	16	19	14	15	36	145	55.7	65.1	25.4	M16	UC 213	FC 213	5.3	
UCFC 214	70	215	177	125.1	17	19	14	18	40	150	61.4	74.6	30.2	M16	UC 214	FC 214	6.8	
UCFC 215	75	220	184	130.1	18	19	16	18	40	160	62.5	77.8	33.3	M16	UC 215	FC 215	7.4	
UCFC 216	80	240	200	141.4	18	23	16	18	42	170	67.3	82.6	33.3	M20	UC 216	FC 216	9.2	
UCFC 217	85	250	208	147.1	18	23	18	20	45	180	69.6	85.7	34.1	M20	UC 217	FC 217	10.6	
UCFC 218	90	265	220	155.5	22	23	18	20	50	190	78.3	96	39.7	M20	UC 218	FC 218	12.7	

FLANGE CARTRIDGE UNITS

UCFC X00 type

Medium Duty
Set-screw Locking

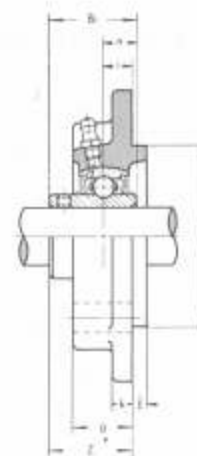
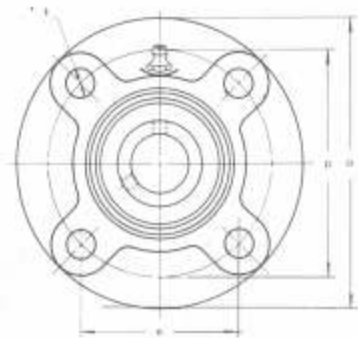

Unit No.	Shaft Diam. mm	Dimensions mm													Bolt Size mm	Bearing No.	Housing No.	Weight kg
		a	p	e	i	s	j	k	g	f	Z	Bi	n					
UCFC X05	25	111	92	65	10	9.5	6	9.5	24	76	32.2	38.1	15.9	M8	UC X05	FC X05	1.1	
UCFC X06	30	127	105	74.2	8	12	9.5	9.5	22.5	85	33.4	42.9	17.5	M10	UC X06	FC X06	1.4	
UCFC X07	35	133	111	78.5	9	12	11	11	26	92	39.2	49.2	19	M10	UC X07	FC X07	1.8	
UCFC X08	40	133	111	78.5	9	12	11	11	26	92	39.2	49.2	19	M10	UC X08	FC X08	1.8	
UCFC X09	45	155	130	91.9	8	14	12	11	25	108	40.6	51.6	19	M12	UC X09	FC X09	2.5	
UCFC X10	50	162	136	96.2	7	14	16	11	25	118	40.4	55.6	22.2	M12	UC X10	FC X10	2.9	
UCFC X11	55	180	152	107.5	4	16	22	13	26	127	43.7	65.1	25.4	M14	UC X11	FC X11	4.0	
UCFC X12	60	194	165	116.7	11	16	20	14	33	140	50.7	75.1	25.4	M14	UC X12	FC X12	4.6	
UCFC X13	65	194	165	116.7	11	16	20	14	33	140	55.4	74.6	30.2	M14	UC X13	FC X13	4.9	
UCFC X14	70	222	190	134.3	14	19	20	14	36	164	58.5	77.8	33.3	M16	UC X14	FC X14	7.4	
UCFC X15	75	222	190	134.3	12	19	22	16	35	164	61.3	82.6	33.3	M16	UC X15	FC X15	7.4	
UCFC X16	80	260	219	154.8	10	23	25	19	36	186	61.6	85.7	34.1	M20	UC X16	FC X16	11.5	
UCFC X17	85	260	219	154.8	10	23	25	19	36	186	66.3	96	39.7	M20	UC X17	FC X17	11.1	
UCFC X18	90	260	219	154.8	12	23	28	19	43	186	73.1	104	42.9	M20	UC X18	FC X18	11.3	
UCFC X20	100	276	238	168.3	22	23	28	22	66	206	90.3	117.5	49.2	M20	UC X20	FC X20	15.9	

FLANGE CARTRIDGE UNITS

UCFS 300 type

Heavy Duty
Set-screw Locking

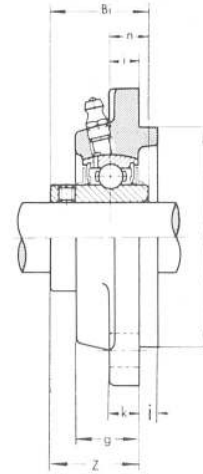
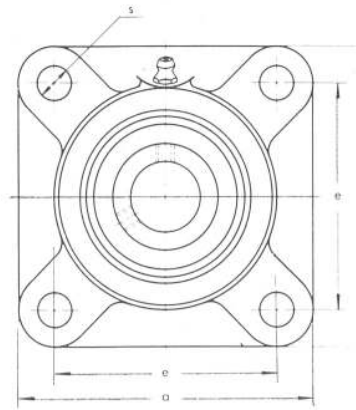

Unit No.	Shaft Diam. mm	Dimensions mm											Bolt Size mm	Bearing No.	Housing No.	Weight kg
		a	e	i	s	j	k	g	f	Z	Bi	n				
UCFS 305	25	110	80	9	16	7	13	22	80	32	38	15	M14	UC 305	FS 305	1.4
UCFS 306	30	125	95	10	16	8	15	24	90	36	43	17	M14	UC 306	FS 306	1.9
UCFS 307	35	135	100	11	19	9	16	27	100	40	48	19	M16	UC 307	FS 307	2.4
UCFS 308	40	150	112	13	19	10	17	30	115	46	52	19	M16	UC 308	FS 308	3.3
UCFS 309	45	160	125	14	19	11	18	33	125	49	57	22	M16	UC 309	FS 309	4.0
UCFS 310	50	175	132	16	23	12	19	36	140	55	61	22	M20	UC 310	FS 310	5.3
UCFS 311	55	185	140	17	23	13	20	39	150	58	66	25	M20	UC 311	FS 311	6.2
UCFS 312	60	195	150	19	23	14	22	42	160	64	71	26	M20	UC 312	FS 312	7.4
UCFS 313	65	208	166	15	23	18	22	40	175	60	75	30	M20	UC 313	FS 313	8.6
UCFS 314	70	226	178	18	25	18	25	43	185	63	78	33	M22	UC 314	FS 314	11.2
UCFS 315	75	236	184	21	25	18	25	48	200	71	82	32	M22	UC 315	FS 315	12.7
UCFS 316	80	250	196	18	31	20	27	48	210	70	86	34	M27	UC 316	FS 316	14.3
UCFS 317	85	260	204	24	31	20	27	54	220	80	96	40	M27	UC 317	FS 317	17.2
UCFS 318	90	280	216	24	35	20	30	56	240	80	96	40	M30	UC 318	FS 318	20.4
UCFS 319	95	290	228	39	35	20	30	74	250	101	103	41	M30	UC 319	FS 319	23.9
UCFS 320	100	310	242	39	38	20	32	74	260	105	108	42	M33	UC 320	FS 320	27.1
UCFS 321	105	310	242	39	38	20	32	74	260	107	112	44	M33	UC 321	FS 321	28.5
UCFS 322	110	340	266	35	41	25	35	71	300	106	117	46	M36	UC 322	FS 322	36.8
UCFS 324	120	370	290	35	41	30	40	80	330	110	126	51	M36	UC 324	FS 324	50.6
UCFS 326	130	410	320	35	41	30	45	85	360	116	135	54	M36	UC 326	FS 326	67.8
UCFS 328	140	450	350	45	41	30	55	95	400	131	145	59	M36	UC 328	FS 328	96.3

FLANGE CARTRIDGE UNITS

* UDFC 200 type

Normal Duty
Eccentric Collar Locking

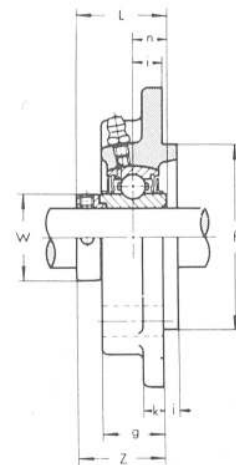
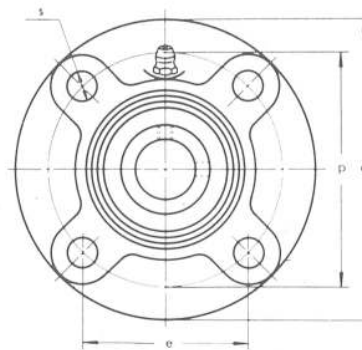

Unit No.	Shaft Diam. mm	Dimensions mm														Bolt Size mm	Bearing No.	Housing No.	Weight kg
		a	p	e	i	s	j	k	g	f	Z	L	n	W					
UDFC 204	20	100	78	55.1	10	12	5	7	20.5	62	29.5	31	11.5	29	M10	UD 204 -EE	FC 204	0.84	
UDFC 205	25	115	90	63.6	10	12	6	7	21	70	30.5	32	11.5	34	M10	UD 205 -EE	FC 205	1.1	
UDFC 206	30	125	100	70.7	10	12	8	8	23	80	33	36	13	40	M10	UD 206 -EE	FC 206	1.5	
UDFC 207	35	135	110	77.8	11	14	8	9	26	90	35.5	38	13.5	48	M12	UD 207 -EE	FC 207	1.7	
UDFC 208	40	145	120	84.8	11	14	10	9	26	100	36.5	40	14.5	53	M12	UD 208 -EE	FC 208	2.0	
UDFC 209	45	160	132	93.3	10	16	12	14	26	105	37	42	15	57	M14	UD 209 -EE	FC 209	2.9	
UDFC 210	50	165	138	97.6	10	16	12	14	28	110	37.5	43	15.5	63	M14	UD 210 -EE	FC 210	3.1	

**FLANGE CARTRIDGE UNITS
WITH CAST IRON COVERS**

CUCFC 200C (CE) type

Normal Duty
Set-screw Locking

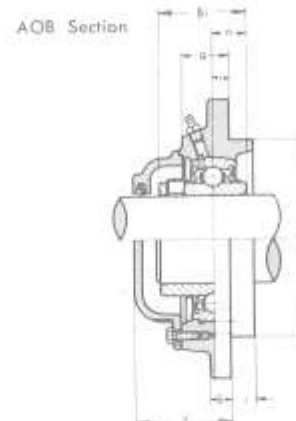
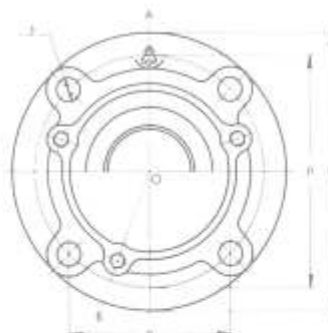

Unit No.		Shaft Diam. mm	Dimensions mm													Bolt Size mm	Bearing No.	Housing No.	Weight kg
Open Cover	Closed Cover		a	p	e	i	s	j	k	g	f	Z	Bi	n					
CUCFC 201C	CUCFC 201CE	12	100	78	55.1	10	12	5	7	20.5	62	41	31	12.7	M10	UC 201	CFC 204	1.2	
CUCFC 202C	CUCFC 202CE	15	100	78	55.1	10	12	5	7	20.5	62	41	31	12.7	M10	UC 202	CFC 204	1.2	
CUCFC 203C	CUCFC 203CE	17	100	78	55.1	10	12	5	7	20.5	62	41	31	12.7	M10	UC 203	CFC 204	1.2	
CUCFC 204C	CUCFC 204CE	20	100	78	55.1	10	12	5	7	20.5	62	41	31	12.7	M10	UC 204	CFC 204	1.2	
CUCFC 205C	CUCFC 205CE	25	115	90	63.6	10	12	6	7	21	70	45	34.1	14.3	M10	UC 205	CFC 205	1.5	
CUCFC 206C	CUCFC 206CE	30	125	100	70.7	10	12	8	8	23	80	47	38.1	15.9	M10	UC 206	CFC 206	2.0	
CUCFC 207C	CUCFC 207CE	35	135	110	77.8	11	14	8	9	26	90	51	42.9	17.5	M12	UC 207	CFC 207	2.4	
CUCFC 208C	CUCFC 208CE	40	145	120	84.8	11	14	10	9	26	100	56	49.2	19	M12	UC 208	CFC 208	2.8	
CUCFC 209C	CUCFC 209CE	45	160	132	93.3	10	16	12	14	26	105	55	49.2	19	M14	UC 209	CFC 209	3.7	
CUCFC 210C	CUCFC 210CE	50	165	138	97.6	10	16	12	14	28	110	59	51.6	19	M14	UC 210	CFC 210	4.2	
CUCFC 211C	CUCFC 211CE	55	185	150	106.1	13	19	12	15	31	125	63	55.6	22.2	M16	UC 211	CFC 211	5.0	
CUCFC 212C	CUCFC 212CE	60	195	160	113.1	17	19	12	15	36	135	74	65.1	25.4	M16	UC 212	CFC 212	6.0	
CUCFC 213C	CUCFC 213CE	65	205	170	120.2	16	19	14	15	36	145	75	65.1	25.4	M16	UC 213	CFC 213	7.0	
CUCFC 214C	CUCFC 214CE	70	215	177	125.1	17	19	14	18	40	150	84	74.6	30.2	M16	UC 214	CFC 214	8.2	
CUCFC 215C	CUCFC 215CE	75	220	184	130.1	18	19	16	18	40	160	86	77.8	33.3	M16	UC 215	CFC 215	8.8	
CUCFC 216C	CUCFC 216CE	80	240	200	141.4	18	23	16	18	42	170	91	82.6	33.3	M20	UC 216	CFC 216	11.3	
CUCFC 217C	CUCFC 217CE	85	250	208	147.1	18	23	18	20	45	180	93	85.7	34.1	M20	UC 217	CFC 217	12.8	
CUCFC 218C	CUCFC 218CE	90	265	220	155.5	22	23	18	20	50	190	104	96	39.7	M20	UC 218	CFC 218	15.9	

**FLANGE CARTRIDGE UNITS
WITH PRESSED STEEL COVERS**

UCFC 200C (E) type

Normal Duty
Set-screw Locking

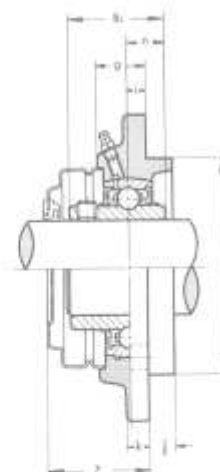

Unit No.		Shaft Diam. mm	Dimensions mm													Bolt Size mm	Bearing No.	Housing No.	Weight kg
Open Cover	Closed Cover		a	p	e	i	s	j	k	g	f	Z	Bi	n					
UCFC 201C	UCFC 201E	12	100	78	55.1	10	12	5	7	20.5	62	38	31	12.7	M10	UC 201	FC 204C	0.92	
UCFC 202C	UCFC 202E	15	100	78	55.1	10	12	5	7	20.5	62	38	31	12.7	M10	UC 202	FC 204C	0.90	
UCFC 203C	UCFC 203E	17	100	78	55.1	10	12	5	7	20.5	62	38	31	12.7	M10	UC 203	FC 204C	0.89	
UCFC 204C	UCFC 204E	20	100	78	55.1	10	12	5	7	20.5	62	38	31	12.7	M10	UC 204	FC 204C	0.87	
UCFC 205C	UCFC 205E	25	115	90	63.6	10	12	6	7	21	70	42	34.1	14.3	M10	UC 205	FC 205C	1.1	
UCFC 206C	UCFC 206E	30	125	100	70.7	10	12	8	8	23	80	43	38.1	15.9	M10	UC 206	FC 206C	1.5	
UCFC 207C	UCFC 207E	35	135	110	77.8	11	14	8	9	26	90	46	42.9	17.5	M12	UC 207	FC 207C	1.8	
UCFC 208C	UCFC 208E	40	145	120	84.8	11	14	10	9	26	100	52	49.2	19	M12	UC 208	FC 208C	2.1	
UCFC 209C	UCFC 209E	45	160	132	93.3	10	16	12	14	26	105	51	49.2	19	M14	UC 209	FC 209C	3.1	
UCFC 210C	UCFC 210E	50	165	138	97.6	10	16	12	14	28	110	54	51.6	19	M14	UC 210	FC 210C	3.3	
UCFC 211C	UCFC 211E	55	185	150	106.1	13	19	12	15	31	125	57	55.6	22.2	M16	UC 211	FC 211C	4.0	
UCFC 212C	UCFC 212E	60	195	160	113.1	17	19	12	15	36	135	68	65.1	25.4	M16	UC 212	FC 212C	4.6	
UCFC 213C	UCFC 213E	65	205	170	120.2	16	19	14	15	36	145	67	65.1	25.4	M16	UC 213	FC 213C	5.5	

TWO-BOLT FLANGE UNITS

UCFL 200 type

Normal Duty
Set-screw Locking

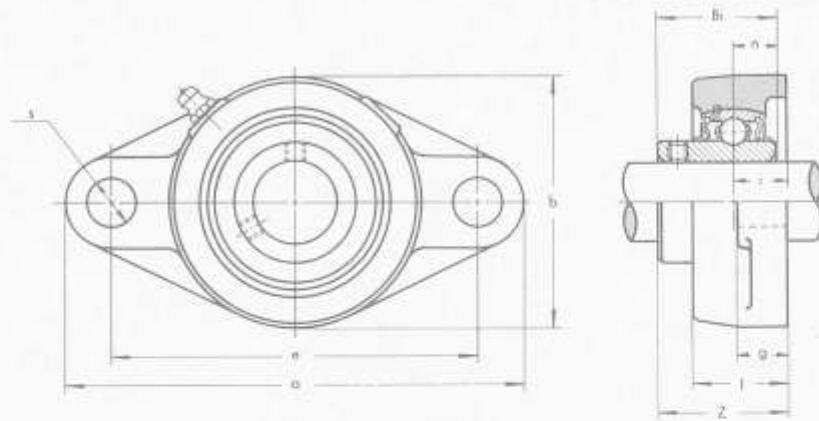

Unit No.	Shaft Diam. mm	Dimensions mm										Bolt Size mm	Bearing No.	Housing No.	Weight kg
		d	e	i	g	l	s	b	Z	Bi	n				
UCFL 201	12	113	90	15	12	25.5	12	60	33.3	31	12.7	M10	UC 201	FL 204	0.50
UCFL 202	15	113	90	15	12	25.5	12	60	33.3	31	12.7	M10	UC 202	FL 204	0.48
UCFL 203	17	113	90	15	12	25.5	12	60	33.3	31	12.7	M10	UC 203	FL 204	0.47
UCFL 204	20	113	90	15	12	25.5	12	60	33.3	31	12.7	M10	UC 204	FL 204	0.45
UCFL 205	25	130	99	16	14	27	16	68	35.7	34.1	14.3	M14	UC 205	FL 205	0.63
UCFL 206	30	148	117	18	14	31	16	80	40.2	38.1	15.9	M14	UC 206	FL 206	0.96
UCFL 207	35	161	130	19	16	34	16	90	44.4	42.9	17.5	M14	UC 207	FL 207	1.2
UCFL 208	40	175	144	21	16	36	16	100	51.2	49.2	19	M14	UC 208	FL 208	1.6
UCFL 209	45	188	148	22	18	38	19	108	52.2	49.2	19	M16	UC 209	FL 209	1.9
UCFL 210	50	197	157	22	18	40	19	115	54.6	51.6	19	M16	UC 210	FL 210	2.2
UCFL 211	55	224	184	25	20	43	19	130	58.4	55.6	22.2	M16	UC 211	FL 211	3.2
UCFL 212	60	250	202	29	20	48	23	140	68.7	65.1	25.4	M20	UC 212	FL 212	4.1
UCFL 213	65	258	210	30	24	50	23	155	69.7	65.1	25.4	M20	UC 213	FL 213	5.1
UCFL 214	70	265	216	31	24	54	23	160	75.4	74.6	30.2	M20	UC 214	FL 214	6.0
UCFL 215	75	275	225	34	24	56	23	165	78.5	77.8	33.3	M20	UC 215	FL 215	6.5
UCFL 216	80	290	233	34	24	58	25	180	83.3	82.6	33.3	M22	UC 216	FL 216	8.0
UCFL 217	85	305	248	36	26	63	25	190	87.6	85.7	34.1	M22	UC 217	FL 217	9.5
UCFL 218	90	320	265	40	26	68	25	205	96.3	96	39.7	M22	UC 218	FL 218	11.9

TWO-BOLT FLANGE UNITS

* UCFT 200 type

Normal Duty
Set-screw Locking

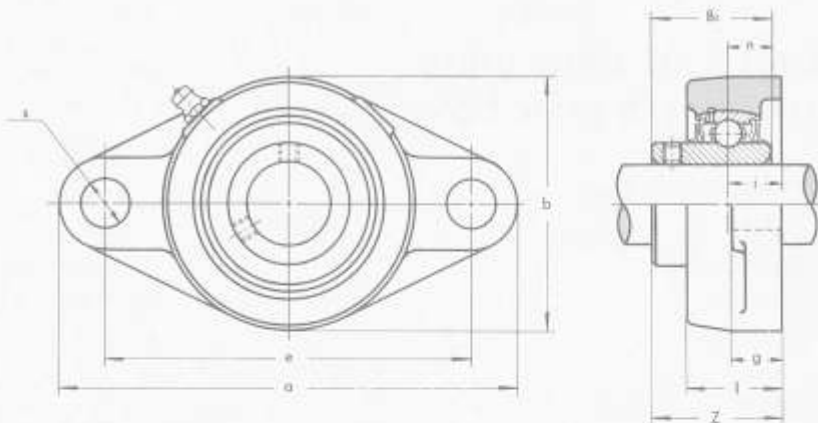

Unit No.	Shaft Diam. mm	Dimensions mm										Bolt Size mm	Bearing No.	Housing No.	Weight kg
		a	e	i	g	l	s	b	Z	Bi	n				
UCFT 201	12	112	76.2	17.1	11	25	10.5	60	33.1	26	10	M 8	UCW 201	FT 203	0.48
UCFT 202	15	112	76.2	17.1	11	25	10.5	60	33.1	26	10	M 8	UCW 202	FT 203	0.47
UCFT 203	17	112	76.2	17.1	11	25	10.5	60	33.1	26	10	M 8	UCW 203	FT 203	0.46
UCFT 204	20	112	89.7	14.3	11	25	10.5	60	32.6	31	12.7	M 8	UC 204	FT 204	0.46
UCFT 205	25	124	98.8	15.9	13	27	12.5	70	35.6	34.1	14.3	M10	UC 205	FT 205	0.64
UCFT 206	30	141	116.7	17.9	13	30	12.5	83	40.1	38.1	15.9	M10	UC 206	FT 206	0.96
UCFT 207	35	156	130.2	19.1	14	34	14	95	44.5	42.9	17.5	M12	UC 207	FT 207	1.4
UCFT 208	40	171	143.7	21	14	38	14	105	51.2	49.2	19	M12	UC 208	FT 208	1.8
UCFT 209	45	179	148.4	21.8	14	40	16	111	52	49.2	19	M14	UC 209	FT 209	2.0
UCFT 210	50	189	157.2	22.2	14	40	16	116	54.8	51.6	19	M14	UC 210	FT 210	2.1
UCFT 211	55	216	184.2	25.4	21	44	18	133	58.8	55.6	22.2	M16	UC 211	FT 211	3.2

TWO-BOLT FLANGE UNITS

UCFL X00 type

Medium Duty
Set-screw Locking

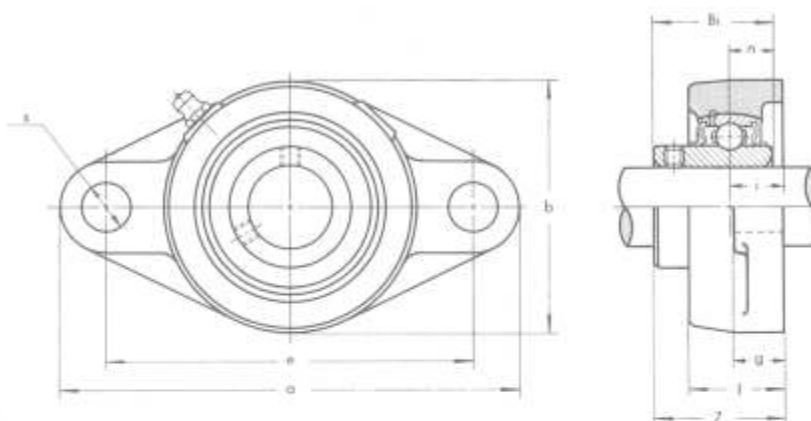

Unit No.	Shaft Diam. mm	Dimensions mm										Bolt Size mm	Bearing No.	Housing No.	Weight kg
		a	e	i	g	l	s	b	Z	Bi	n				
UCFL X05	25	141	117	18	13	30	12	83	40.2	38.1	15.9	M10	UC X05	FL X05	1.0
UCFL X06	30	156	130	19	14	34	16	95	44.4	42.9	17.5	M14	UC X06	FL X06	1.4
UCFL X07	35	171	144	21	14	38	16	105	51.2	49.2	19	M14	UC X07	FL X07	1.9
UCFL X08	40	179	148	22	14	40	16	111	52.2	49.2	19	M14	UC X08	FL X08	2.0
UCFL X09	45	189	157	23	14	40	16	116	55.6	51.6	19	M14	UC X09	FL X09	2.4
UCFL X10	50	216	184	26	20	44	19	133	59.4	55.6	22.2	M16	UC X10	FL X10	3.6

TWO-BOLT FLANGE UNITS

UCFL 300 type

Heavy Duty
Set-screw Locking

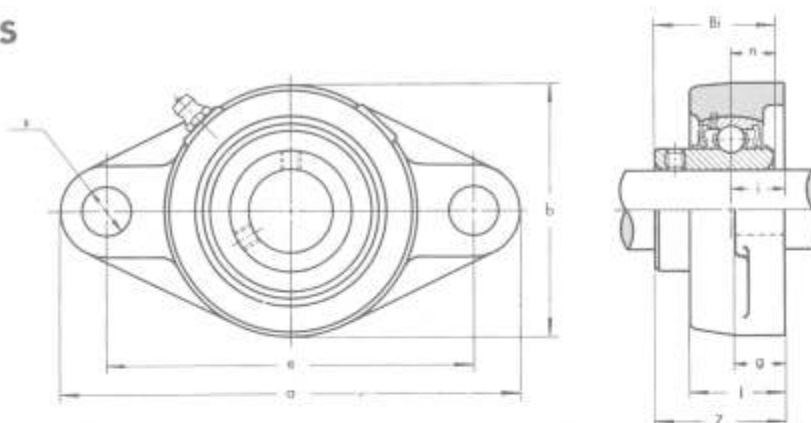

Unit No.	Shaft Diam. mm	Dimensions mm										Bolt Size mm	Bearing No.	Housing No.	Weight kg
		a	e	i	g	l	s	b	Z	Bi	n				
UCFL 305	25	150	113	16	13	29	19	80	39	38	15	M16	UC 305	FL 305	1.1
UCFL 306	30	180	134	18	15	32	23	90	44	43	17	M20	UC 306	FL 306	1.5
UCFL 307	35	185	141	20	16	36	23	100	49	48	19	M20	UC 307	FL 307	1.8
UCFL 308	40	200	158	23	17	40	23	112	56	52	19	M20	UC 308	FL 308	2.4
UCFL 309	45	230	177	25	18	44	25	125	60	57	22	M22	UC 309	FL 309	3.4
UCFL 310	50	240	187	28	19	48	25	140	67	61	22	M22	UC 310	FL 310	4.3
UCFL 311	55	250	198	30	20	52	25	150	71	66	25	M22	UC 311	FL 311	5.1
UCFL 312	60	270	212	33	22	56	31	160	78	71	26	M27	UC 312	FL 312	6.2
UCFL 313	65	295	240	33	25	58	31	175	78	75	30	M27	UC 313	FL 313	7.4
UCFL 314	70	315	250	36	28	61	35	185	81	78	33	M30	UC 314	FL 314	9.0
UCFL 315	75	320	260	39	30	66	35	195	89	82	32	M30	UC 315	FL 315	10.0
UCFL 316	80	355	285	38	32	68	38	210	90	86	34	M33	UC 316	FL 316	12.6
UCFL 317	85	370	300	44	32	74	38	220	100	96	40	M33	UC 317	FL 317	14.5
UCFL 318	90	385	315	44	36	76	38	235	100	96	40	M33	UC 318	FL 318	17.1
UCFL 319	95	405	330	59	40	94	41	250	121	103	41	M36	UC 319	FL 319	21.8
UCFL 320	100	440	360	59	40	94	44	270	125	108	42	M39	UC 320	FL 320	26.5
UCFL 321	105	440	360	59	40	94	44	270	127	112	44	M39	UC 321	FL 321	28.2
UCFL 322	110	470	390	60	42	96	44	300	131	117	46	M39	UC 322	FL 322	33.1
UCFL 324	120	520	430	65	48	110	47	330	140	126	51	M42	UC 324	FL 324	45.7
UCFL 326	130	550	460	65	50	115	47	360	146	135	54	M42	UC 326	FL 326	57.5
UCFL 328	140	600	500	75	60	125	51	400	161	145	59	M45	UC 328	FL 328	79.7

TWO-BOLT FLANGE UNITS

* UDFL 200 type
Normal Duty
Eccentric Collar Locking

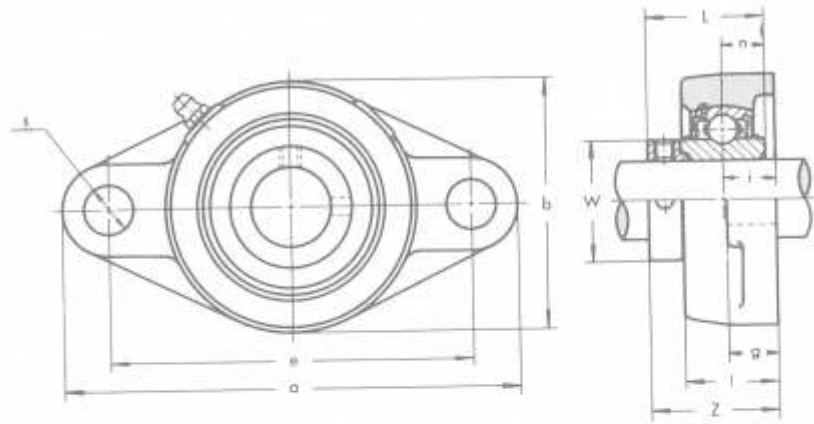

Unit No.	Shaft Diam. mm	Dimensions mm											Bolt Size mm	Bearing No.	Housing No.	Weight kg
		a	e	l	g	i	s	b	Z	L	n	W				
UDFL 204	20	113	90	15	12	25.5	12	60	34.5	31	11.5	29	M10	UD 204 +EE	FL 204	0.45
UDFL 205	25	130	99	16	14	27	16	68	36.5	32	11.5	34	M14	UD 205 +EE	FL 205	0.62
UDFL 206	30	148	117	18	14	31	16	80	41	36	13	40	M14	UD 206 +EE	FL 206	0.95
UDFL 207	35	161	130	19	16	34	16	90	43.5	38	13.5	48	M14	UD 207 -EE	FL 207	1.2
UDFL 208	40	175	144	21	16	36	16	100	46.5	40	14.5	53	M14	UD 208 -EE	FL 208	1.5
UDFL 209	45	188	148	22	18	38	19	108	49	42	15	57	M16	UD 209 -EE	FL 209	1.9
UDFL 210	50	197	157	22	18	40	19	115	49.5	43	15.5	63	M16	UD 210 +EE	FL 210	2.1

TWO-BOLT FLANGE UNITS WITH CAST IRON COVERS

CUCFL 200C(CE) type

Normal Duty
Set-screw Locking

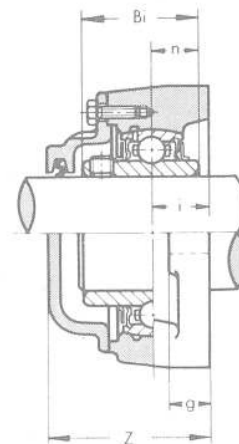
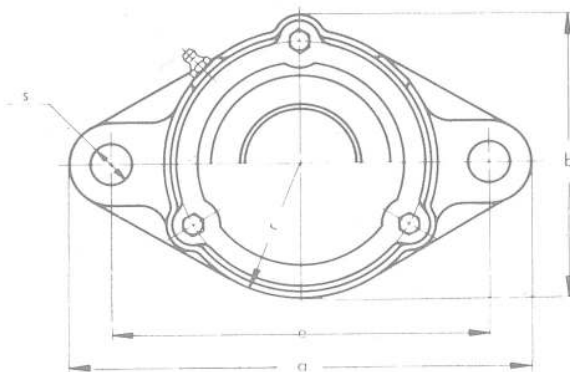

Unit No.		Shaft Diam. mm	Dimensions mm										Bolt Size mm	Bearing No.	Housing No.	Weight kg
Open Cover	Closed Cover		a	e	i	g	b	r	s	Z	Bi	n				
CUCFL 201C	CUCFL 201CE	12	113	90	15	12	66	30	12	46	31	12.7	M10	UC 201	CFL 204	0.8
CUCFL 202C	CUCFL 202CE	15	113	90	15	12	66	30	12	46	31	12.7	M10	UC 202	CFL 204	0.8
CUCFL 203C	CUCFL 203CE	17	113	90	15	12	66	30	12	46	31	12.7	M10	UC 203	CFL 204	0.8
CUCFL 204C	CUCFL 204CE	20	113	90	15	12	66	30	12	46	31	12.7	M10	UC 204	CFL 204	0.8
CUCFL 205C	CUCFL 205CE	25	130	99	16	14	73	34	16	51	34.1	14.3	M14	UC 205	CFL 205	1.0
CUCFL 206C	CUCFL 206CE	30	148	117	18	14	84	40	16	55	38.1	15.9	M14	UC 206	CFL 206	1.5
CUCFL 207C	CUCFL 207CE	35	161	130	19	16	94	45	16	59	42.9	17.5	M14	UC 207	CFL 207	1.9
CUCFL 208C	CUCFL 208CE	40	175	144	21	16	104	50	16	66	49.2	19	M14	UC 208	CFL 208	2.3
CUCFL 209C	CUCFL 209CE	45	188	148	22	18	113	54	19	67	49.2	19	M16	UC 209	CFL 209	2.7
CUCFL 210C	CUCFL 210CE	50	197	157	22	18	120	58	19	71	51.6	19	M16	UC 210	CFL 210	3.2
CUCFL 211C	CUCFL 211CE	55	224	184	25	20	134	65	19	75	55.6	22.2	M16	UC 211	CFL 211	4.3
CUCFL 212C	CUCFL 212CE	60	250	202	29	20	144	70	23	86	65.1	25.4	M20	UC 212	CFL 212	5.4
CUCFL 213C	CUCFL 213CE	65	258	210	30	24	157	78	23	89	65.1	25.4	M20	UC 213	CFL 213	6.7
CUCFL 214C	CUCFL 214CE	70	265	216	31	24	163	80	23	98	74.6	30.2	M20	UC 214	CFL 214	7.4
CUCFL 215C	CUCFL 215CE	75	275	225	34	24	168	83	23	102	77.8	33.3	M20	UC 215	CFL 215	7.9
CUCFL 216C	CUCFL 216CE	80	290	233	34	24	188	90	25	107	82.6	33.3	M22	UC 216	CFL 216	10.2
CUCFL 217C	CUCFL 217CE	85	305	248	36	26	198	95	25	111	85.7	34.1	M22	UC 217	CFL 217	11.8
CUCFL 218C	CUCFL 218CE	90	320	265	40	26	211	103	25	122	96	39.7	M22	UC 218	CFL 218	15.0

TWO-BOLT FLANGE UNITS WITH PRESSED STEEL COVERS

UCFL 200C(E) type

Normal Duty
Set-screw Locking

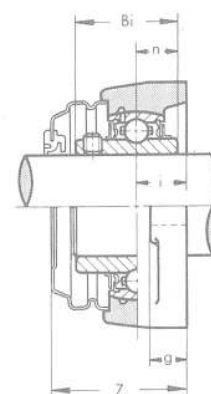
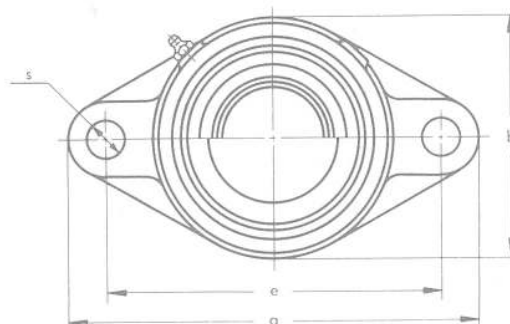

Unit No.		Shaft Diam. mm	Dimensions mm										Bolt Size mm	Bearing No.	Housing No.	Weight kg
Open Cover	Closed Cover		a	e	i	g	b	s	Z	Bi	n					
UCFL 201C	UCFL 201E	12	113	90	15	12	60	12	43	31	12.7	M10	UC 201	FL 204C	0.53	
UCFL 202C	UCFL 202E	15	113	90	15	12	60	12	43	31	12.7	M10	UC 202	FL 204C	0.51	
UCFL 203C	UCFL 203E	17	113	90	15	12	60	12	43	31	12.7	M10	UC 203	FL 204C	0.50	
UCFL 204C	UCFL 204E	20	113	90	15	12	60	12	43	31	12.7	M10	UC 204	FL 204C	0.48	
UCFL 205C	UCFL 205E	25	130	99	16	14	68	16	47	34.1	14.3	M14	UC 205	FL 205C	0.67	
UCFL 206C	UCFL 206E	30	148	117	18	14	80	16	49	38.1	15.9	M14	UC 206	FL 206C	1.0	
UCFL 207C	UCFL 207E	35	161	130	19	16	90	16	54	42.9	17.5	M14	UC 207	FL 207C	1.3	
UCFL 208C	UCFL 208E	40	175	144	21	16	100	16	61	49.2	19	M14	UC 208	FL 208C	1.7	
UCFL 209C	UCFL 209E	45	188	148	22	18	108	19	63	49.2	19	M16	UC 209	FL 209C	2.0	
UCFL 210C	UCFL 210E	50	197	157	22	18	115	19	66	51.6	19	M16	UC 210	FL 210C	2.3	
UCFL 211C	UCFL 211E	55	224	184	25	20	130	19	69	55.6	22.2	M16	UC 211	FL 211C	3.3	
UCFL 212C	UCFL 212E	60	250	202	29	20	140	23	80	65.1	25.4	M20	UC 212	FL 212C	4.3	
UCFL 213C	UCFL 213E	65	258	210	30	24	155	23	81	65.1	25.4	M20	UC 213	FL 213C	5.3	

TWO-BOLT FLANGE UNITS

BFL 200 type

Light Duty
Set-screw Locking

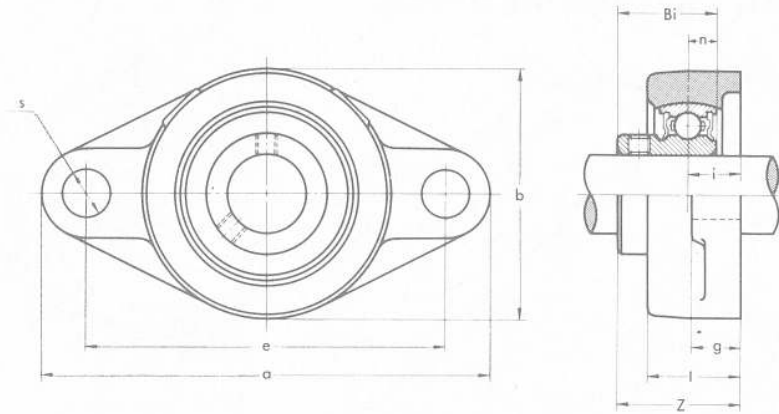

Unit No.	Shaft Diam. mm	Dimensions mm										Bolt Size mm	Bearing No.	Housing No.	Weight kg
		a	e	i	g	l	s	b	Z	Bi	n				
BFL 204	20	113	90	15	12	25.5	12	60	32.7	24.7	7	M10	B 4	FL 204	0.41
BFL 205	25	130	99	16	14	27	16	68	35.5	27	7.5	M14	B 5	FL 205	0.60
BFL 206	30	148	117	18	14	31	16	80	40.3	30.3	8	M14	B 6	FL 206	0.88
BFL 207	35	161	130	19	16	34	16	90	43.4	32.9	8.5	M14	B 7	FL 207	1.2

TWO-BOLT FLANGE UNITS

BLFL type

Light Duty
Set-screw Locking

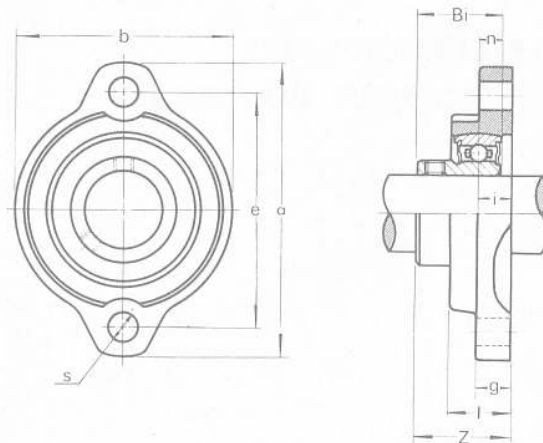

Unit No.	Shaft Diam. mm	Dimensions mm										Bolt Size mm	Bearing No.	Housing No.	Weight kg
		a	e	i	g	l	s	b	Z	Bi	n				
BLFL 1J	12	81	63.5	9.5	9.5	18	7	56	25.5	22	6	M6	B 1	LFL 3J	0.28
BLFL 2J	15	81	63.5	9.5	9.5	18	7	56	25.5	22	6	M6	B 2	LFL 3J	0.27
BLFL 3J	17	81	63.5	9.5	9.5	18	7	56	25.5	22	6	M6	B 3	LFL 3J	0.25
BLFL 4J	20	90	71.5	11	11	20	10	63	28.7	24.7	7	M8	B 4	LFL 4J	0.30
BLFL 5J	25	95	76	11	11	20	10	69	30.5	27	7.5	M8	B 5	LFL 5J	0.40
BLFL 6J	30	113	90.5	12	12	22.5	12	79	34.3	30.3	8	M10	B 6	LFL 6J	0.58
BLFL 7J	35	122	100	13	13	24	12	89	37.4	32.9	8.5	M10	B 7	LFL 7J	0.81

MALLEABLE HOUSING TWO-BOLT FLANGE UNITS

- * BFX 200 type
- * KHFX 200 type

Light Duty

OBSOLETE

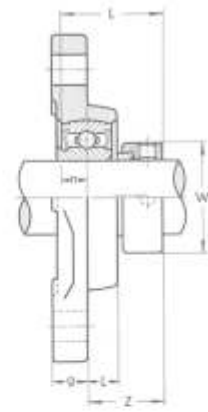
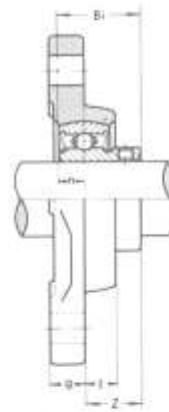
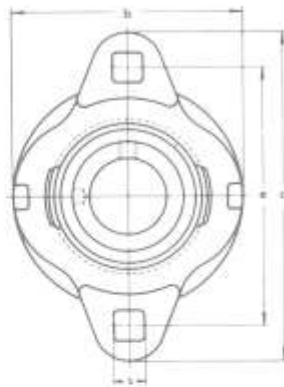

BFX 200 type
Set-screw Locking

KHFX 200 type
Eccentric Collar Locking

Unit No.		Shaft Diam. mm	Dimensions mm										Bolt Size mm	Housing No.	Weight kg					
Complete with B type	Complete with KH200 + AE type		a	e	g	l	s	b	Z		o (Min.)	W			Bi	l	n		BFX	KHFX
BFX 201	KHFX 201	12	81	64	10	8	7	56	16	22	48	28.6	22	28.6	6	6.5	M6	FX 203K	0.22	0.26
BFX 202	KHFX 202	15	81	64	10	8	7	56	16	22	48	28.6	22	28.6	6	6.5	M6	FX 203K	0.21	0.25
BFX 203	KHFX 203	17	81	64	10	8	7	56	16	22	48	28.6	22	28.6	6	6.5	M6	FX 203K	0.19	0.24
BFX 204	KHFX 204	20	90	71	11	9	9	63	17.5	23.5	55	33.3	24.7	31	7	7.5	M8	FX 204K	0.28	0.28
BFX 205	KHFX 205	25	95	76	11	9	9	69	19.3	22.8	60	38.1	27	31	7.5	7.5	M8	FX 205K	0.34	0.36
BFX 206	KHFX 206	30	113	90	12	11	10	79	22.5	26.5	71	44.5	30.3	35.7	8	9	M10	FX 206K	0.50	0.56
BFX 207	KHFX 207	35	122	100	13	11	10	89	24.5	29.5	82	55.6	32.9	38.9	8.5	9.5	M10	FX 207K	0.66	0.79

PRESSED STEEL HOUSING
TWO-BOLT FLANGE UNITS

BPFL type

Light Duty
Set-screw Locking

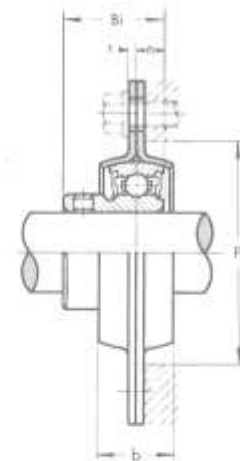
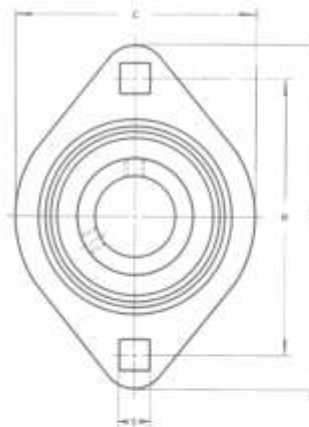

Unit No.	Shaft Diam. mm	Dimensions mm									Bolt Size mm	Bearing No.	Housing No.	Weight kg
		a	e	f	b	s	c	F (Min.)	Bi	n				
BPFL 1	12	81	63.5	2	14	7	59	49	22	6	M6	B 1	PFL 3	0.25
BPFL 2	15	81	63.5	2	14	7	59	49	22	6	M6	B 2	PFL 3	0.24
BPFL 3	17	81	63.5	2	14	7	59	49	22	6	M6	B 3	PFL 3	0.22
BPFL 4	20	90	71.5	2	16	9	67	56	24.7	7	M8	B 4	PFL 4	0.29
BPFL 5	25	95	76	2	18	9	71	60	27	7.5	M8	B 5	PFL 5	0.36
BPFL 6	30	113	90.5	2.6	18	11	84	71	30.3	8	M10	B 6	PFL 6	0.56
BPFL 7	35	125	100	2.6	20	11	94	81	32.9	8.5	M10	B 7	PFL 7	0.70

ADJUSTABLE FLANGE UNITS

UCFA 200 type

Normal Duty
Set-screw Locking

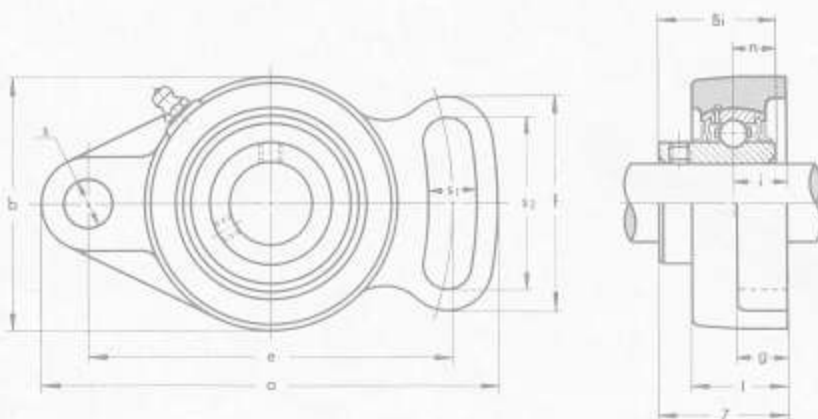

Unit No.	Shaft Diam. mm	Dimensions mm														Bolt Size mm	Bearing No.	Housing No.	Weight kg
		a	e	i	g	l	s	s ₁	s ₂	b	f	Z	Bi	n					
UCFA 201	12	102	78	15	12	25.5	10	10	40	60	54	33.3	31	12.7	M8	UC 201	FA 204	0.50	
UCFA 202	15	102	78	15	12	25.5	10	10	40	60	54	33.3	31	12.7	M8	UC 202	FA 204	0.49	
UCFA 203	17	102	78	15	12	25.5	10	10	40	60	54	33.3	31	12.7	M8	UC 203	FA 204	0.48	
UCFA 204	20	102	78	15	12	25.5	10	10	40	60	54	33.3	31	12.7	M8	UC 204	FA 204	0.46	
UCFA 205	25	125	98	16	14	27	12	13	51	68	65	35.7	34.1	14.3	M10	UC 205	FA 205	0.66	
UCFA 206	30	144	117	18	14	31	12	13	58	80	72	40.2	38.1	15.9	M10	UC 206	FA 206	1.0	
UCFA 207	35	161	130	19	16	34	14	15	66	90	82	44.4	42.9	17.5	M12	UC 207	FA 207	1.4	
UCFA 208	40	175	144	21	16	36	14	15	71	100	87	51.2	49.2	19	M12	UC 208	FA 208	1.7	
UCFA 209	45	181	148	22	18	38	16	17	72	108	90	52.2	49.2	19	M14	UC 209	FA 209	2.0	
UCFA 210	50	190	157	22	18	40	16	17	76	115	94	54.6	51.6	19	M14	UC 210	FA 210	2.4	
UCFA 211	55	219	184	25	20	43	16	17	86	130	104	58.4	55.6	22.2	M14	UC 211	FA 211	3.4	

THREE-BOLT FLANGE BRACKET UNITS

UCFK 200 type

Normal Duty
Set-screw Locking

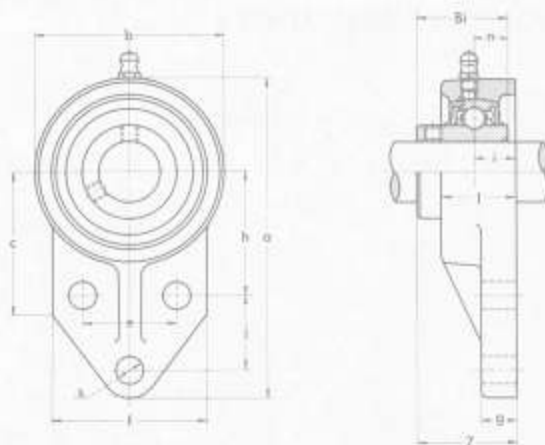

Unit No.	Shaft Diam. mm	Dimensions mm														Bolt Size mm	Bearing No.	Housing No.	Weight kg
		a	h	e	i	i	g	l	c	s	b	f	Z	Bi	n				
UCFK 201	12	110	42	32	27	15	13	25.5	52	10	62	52	33.3	31	12.7	M8	UC 201	FK 204	0.60
UCFK 202	15	110	42	32	27	15	13	25.5	52	10	62	52	33.3	31	12.7	M8	UC 202	FK 204	0.58
UCFK 203	17	110	42	32	27	15	13	25.5	52	10	62	52	33.3	31	12.7	M8	UC 203	FK 204	0.57
UCFK 204	20	110	42	32	27	15	13	25.5	52	10	62	52	33.3	31	12.7	M8	UC 204	FK 204	0.55
UCFK 205	25	116	45	34	27	16	13	27	52	10	68	56	35.7	34.1	14.3	M8	UC 205	FK 205	0.66
UCFK 206	30	130	50	40	29	18	13	31	55	10	78	65	40.2	38.1	15.9	M8	UC 206	FK 206	0.93
UCFK 207	35	144	55	46	32	19	15	34	62	10	90	70	44.4	42.9	17.5	M8	UC 207	FK 207	1.3
UCFK 208	40	164	60	50	41	21	16	36	72	12	100	78	51.2	49.2	19	M10	UC 208	FK 208	1.7
UCFK 209	45	174	65	54	43	22	18	38	76	12	106	80	52.2	49.2	19	M10	UC 209	FK 209	1.9
UCFK 210	50	184	68	58	46	22	18	40	82	12	112	86	54.6	51.6	19	M10	UC 210	FK 210	2.2

TAKE-UP UNITS

UCT 200 type

Normal Duty
Set-screw Locking

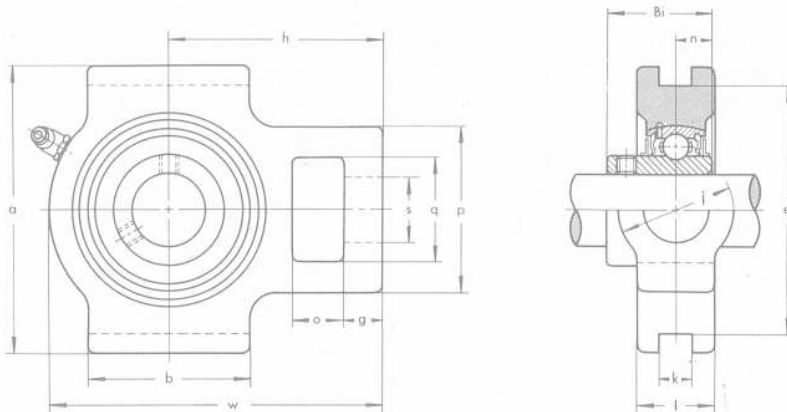

Unit No.	Shaft Diam. mm	Dimensions mm															Bearing No.	Housing No.	Weight kg
		o	g	p	q	s	b	k	e	a	w	j	l	h	Bi	n			
UCT 201	12	16	10	51	32	19	51	12	76	89	94	32	21	61	31	12.7	UC 201	T 204	0.79
UCT 202	15	16	10	51	32	19	51	12	76	89	94	32	21	61	31	12.7	UC 202	T 204	0.77
UCT 203	17	16	10	51	32	19	51	12	76	89	94	32	21	61	31	12.7	UC 203	T 204	0.76
UCT 204	20	16	10	51	32	19	51	12	76	89	94	32	21	61	31	12.7	UC 204	T 204	0.74
UCT 205	25	16	10	51	32	19	51	12	76	89	97	32	24	62	34.1	14.3	UC 205	T 205	0.82
UCT 206	30	16	10	56	37	22	57	12	89	102	113	37	28	70	38.1	15.9	UC 206	T 206	1.3
UCT 207	35	16	13	64	37	22	64	12	89	102	129	37	30	78	42.9	17.5	UC 207	T 207	1.6
UCT 208	40	19	16	83	49	29	83	16	102	114	144	49	33	88	49.2	19	UC 208	T 208	2.4
UCT 209	45	19	16	83	49	29	83	16	102	117	144	49	35	87	49.2	19	UC 209	T 209	2.4
UCT 210	50	19	16	83	49	29	86	16	102	117	149	49	37	90	51.6	19	UC 210	T 210	2.5
UCT 211	55	25	19	102	64	35	95	22	130	146	171	64	38	106	55.6	22.2	UC 211	T 211	4.0
UCT 212	60	32	19	102	64	35	102	22	130	146	194	64	42	119	65.1	25.4	UC 212	T 212	5.1
UCT 213	65	32	21	111	70	41	121	26	151	167	224	70	44	137	65.1	25.4	UC 213	T 213	7.0
UCT 214	70	32	21	111	70	41	121	26	151	167	224	70	46	137	74.6	30.2	UC 214	T 214	7.1
UCT 215	75	32	21	111	70	41	121	26	151	167	232	70	48	140	77.8	33.3	UC 215	T 215	7.5
UCT 216	80	32	21	111	70	41	121	26	165	184	235	70	51	140	82.6	33.3	UC 216	T 216	8.5
UCT 217	85	38	29	124	73	48	157	30	173	198	260	73	54	162	85.7	34.1	UC 217	T 217	11.2

* TAKE-UP UNITS

UCST 200 type

Normal Duty
Set-screw Locking

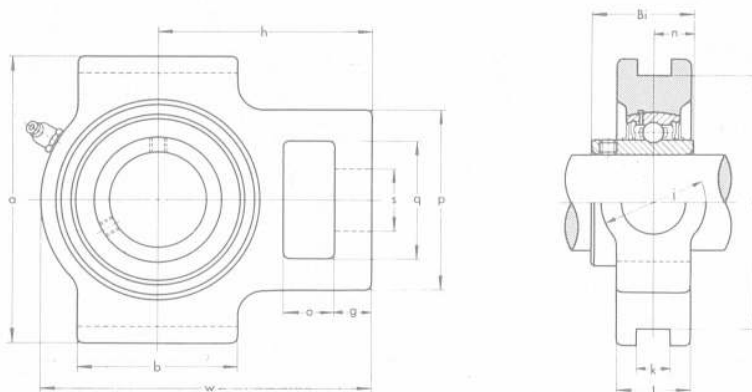

Unit No.	Shaft Diam. mm	Dimensions mm															Bearing No.	Housing No.	Weight kg
		o	g	p	q	s	b	k	e	a	w	j	l	h	Bi	n			
UCST 204	20	16	10	51	32	19	51	13.5	76.2	89	94	32	24	60	31	12.7	UC 204	ST 204	0.84
UCST 205	25	16	10	51	32	22	51	13.5	76.2	89	97	32	24	62	34.1	14.3	UC 205	ST 205	0.80
UCST 206	30	16	10	56	37	22	57	13.5	88.9	102	113	37	24	70	38.1	15.9	UC 206	ST 206	1.1
UCST 207	35	16	13	64	37	22	64	13.5	88.9	102	129	37	30	78	42.9	17.5	UC 207	ST 207	1.6
UCST 208	40	19	16	83	49	29	83	17.5	101.6	114	144	49	35	89	49.2	19	UC 208	ST 208	2.5
UCST 209	45	19	16	83	49	29	83	17.5	101.6	117	144	49	35	87	49.2	19	UC 209	ST 209	2.4
UCST 210	50	19	16	83	49	29	86	17.5	101.6	117	149	49	35	90	51.5	19	UC 210	ST 210	2.4
UCST 211	55	25	19	102	64	35	95	27	130.2	146	171	64	41	106	55.6	22.2	UC 211	ST 211	4.1
UCST 212	60	32	19	102	64	35	102	27	130.2	146	194	64	46	119	65.1	25.4	UC 212	ST 212	5.0
UCST 213	65	32	21	111	70	41	121	27	150.8	167	224	70	51	137	65.1	25.4	UC 213	ST 213	7.1

TAKE-UP UNITS

UCT X00 type

Medium Duty
Set-screw Locking

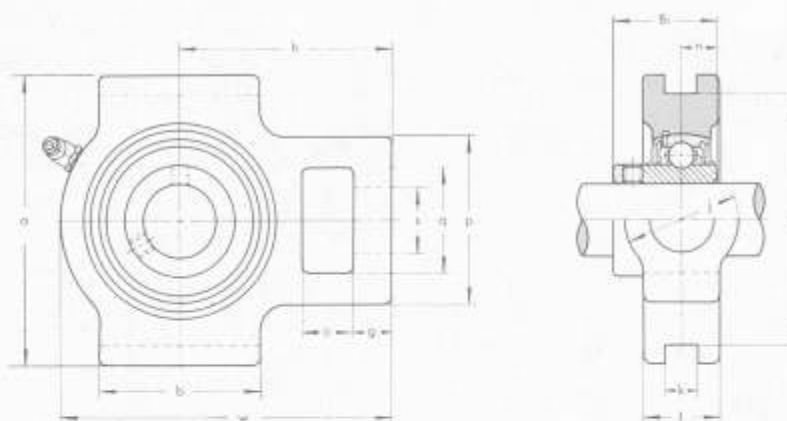

Unit No.	Shaft Diam. mm	Dimensions mm															Bearing No.	Housing No.	Weight kg
		a	g	p	q	s	b	k	e	a	w	j	l	h	Bi	n			
UCT X05	25	16	10	56	37	22	57	12	89	102	113	37	28	70	38.1	15.9	UC X05	T X05	1.3
UCT X06	30	16	13	64	37	22	64	12	89	102	129	37	30	78	42.9	17.5	UC X06	T X06	1.6
UCT X07	35	19	15	83	49	29	83	16	102	114	144	49	36	88	49.2	19	UC X07	T X07	2.6
UCT X08	40	19	15	83	49	29	83	16	102	117	144	49	36	87	49.2	19	UC X08	T X08	2.6
UCT X09	45	19	16	83	49	29	86	16	102	117	149	49	38	90	51.6	19	UC X09	T X09	2.8
UCT X10	50	25	19	102	64	35	95	22	130	146	171	64	42	106	55.6	22.2	UC X10	T X10	4.4
UCT X11	55	32	19	102	64	35	102	22	130	146	194	64	44	119	65.1	25.4	UC X11	T X11	5.2
UCT X12	60	32	21	111	70	41	121	26	151	167	224	70	48	137	65.1	25.4	UC X12	T X12	7.2
UCT X13	65	32	21	111	70	41	121	26	151	167	224	70	48	137	74.6	30.2	UC X13	T X13	7.4
UCT X14	70	32	21	111	70	41	121	26	151	167	232	70	48	140	77.8	33.3	UC X14	T X14	7.7
UCT X15	75	32	21	111	70	41	121	28	165	184	235	70	48	140	82.6	33.3	UC X15	T X15	8.4
UCT X16	80	38	28	124	73	48	157	28	173	198	260	73	54	162	85.7	34.1	UC X16	T X16	11.3
UCT X17	85	38	28	124	73	48	157	28	173	198	260	73	54	162	96	39.7	UC X17	T X17	11.0

TAKE-UP UNITS

UCT 300 type

Heavy Duty
Set-screw Locking

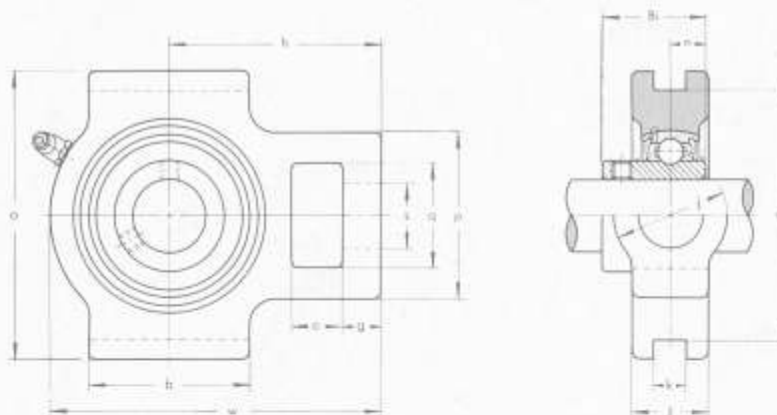

Unit No.	Shaft Diam. mm	Dimensions mm															Bearing No.	Housing No.	Weight kg
		a	g	p	q	s	b	k	e	a	w	j	l	h	Bi	n			
UCT 305	25	16	12	62	36	26	65	12	80	89	122	36	26	76	38	15	UC 305	T 305	1.4
UCT 306	30	18	14	70	41	28	74	16	90	100	137	41	28	85	43	17	UC 306	T 306	1.8
UCT 307	35	20	15	75	45	30	80	16	100	111	150	45	32	94	48	19	UC 307	T 307	2.4
UCT 308	40	22	17	83	50	32	89	18	112	124	162	50	34	100	52	19	UC 308	T 308	3.0
UCT 309	45	24	18	90	55	34	97	18	125	138	178	55	38	110	57	22	UC 309	T 309	4.1
UCT 310	50	27	20	98	61	37	106	20	140	151	191	61	40	117	61	22	UC 310	T 310	5.2
UCT 311	55	29	21	105	66	39	115	22	150	163	207	66	44	127	66	25	UC 311	T 311	6.4
UCT 312	60	31	23	113	71	41	123	22	160	178	220	71	46	135	71	26	UC 312	T 312	7.6
UCT 313	65	32	25	116	70	43	134	26	170	190	238	80	50	146	75	30	UC 313	T 313	9.2
UCT 314	70	36	25	130	85	46	140	26	180	202	252	90	52	155	78	33	UC 314	T 314	11.2
UCT 315	75	36	25	132	85	46	150	26	192	216	262	90	55	160	82	32	UC 315	T 315	13.0
UCT 316	80	42	28	150	98	53	160	30	204	230	282	102	60	174	86	34	UC 316	T 316	15.6
UCT 317	85	42	30	152	98	53	170	32	214	240	298	102	64	183	96	40	UC 317	T 317	19.3
UCT 318	90	46	30	160	106	57	175	32	228	255	312	110	66	192	96	40	UC 318	T 318	21.2
UCT 319	95	46	31	165	106	57	180	35	240	270	322	110	72	197	103	41	UC 319	T 319	24.4
UCT 320	100	48	32	175	115	59	200	35	260	290	345	120	75	210	108	42	UC 320	T 320	30.6
UCT 321	105	48	32	175	115	59	200	35	260	290	345	120	75	210	112	44	UC 321	T 321	30.2
UCT 322	110	52	38	185	125	65	215	38	285	320	385	130	80	235	117	46	UC 322	T 322	38.8
UCT 324	120	60	42	210	140	70	230	45	320	355	432	140	90	267	126	51	UC 324	T 324	54.6
UCT 326	130	65	45	220	150	75	240	50	350	385	465	150	100	285	135	54	UC 326	T 326	68.4
UCT 328	140	70	50	230	160	80	255	50	380	415	515	155	100	315	145	59	UC 328	T 328	83.2

TAKE-UP UNITS

* UDT 200 type

Normal Duty
Eccentric Collar Locking

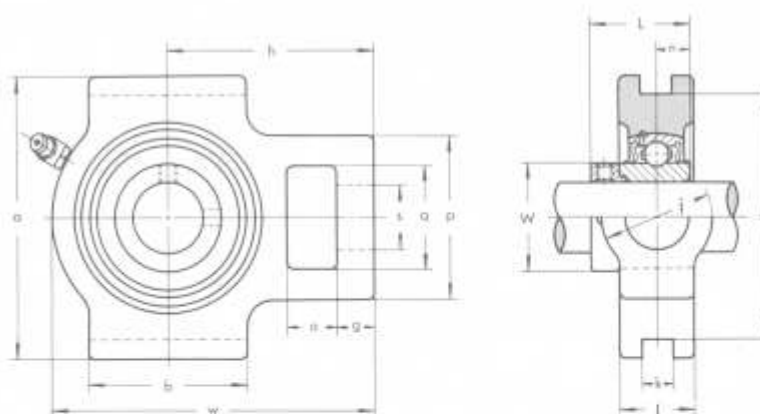

Unit No.	Shaft Diam. mm	Dimensions mm																Bearing No.	Housing No.	Weight kg
		a	g	p	q	s	b	k	e	a	w	i	l	h	L	n	W			
UDT 204	20	16	10	51	32	19	51	12	76	89	94	32	21	61	31	11.5	29	UD 204 +EE	T 204	0.74
UDT 205	25	16	10	51	32	19	51	12	76	89	97	32	24	62	32	11.5	34	UD 205 +EE	T 205	0.81
UDT 206	30	16	10	56	37	22	57	12	89	102	113	37	28	70	36	13	40	UD 206 +EE	T 206	1.3
UDT 207	35	16	13	64	37	22	64	12	89	102	129	37	30	78	38	13.5	48	UD 207 +EE	T 207	1.6
UDT 208	40	19	16	83	49	29	83	16	102	114	144	49	33	88	40	14.5	53	UD 208 +EE	T 208	2.3
UDT 209	45	19	16	83	49	29	83	16	102	117	144	49	35	87	42	15	57	UD 209 +EE	T 209	2.4
UDT 210	50	19	16	83	49	29	86	16	102	117	149	49	37	90	43	15.5	63	UD 210 +EE	T 210	2.4

TAKE-UP UNITS WITH CAST IRON COVERS

CUCT 200C (CE) type

Normal Duty
Set-screw Locking

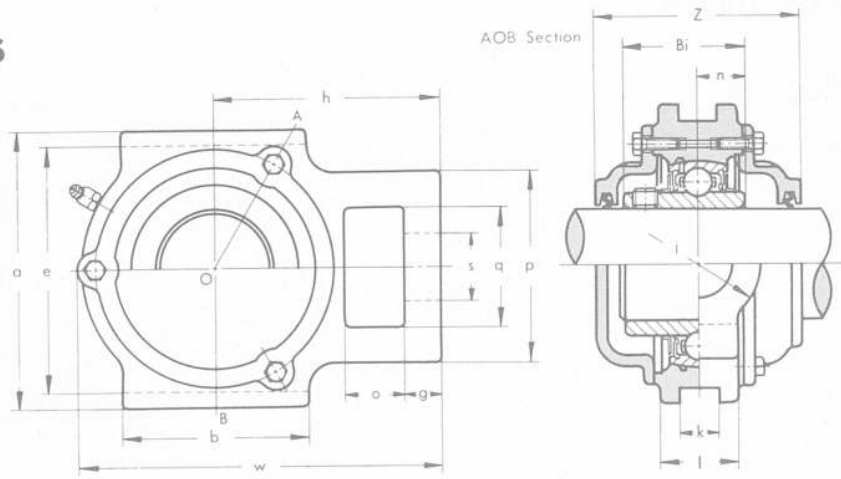

Unit No.		Shaft Diam. mm	Dimensions mm														Bearing No.	Housing No.	Weight kg		
Open Cover	Closed Cover		o	g	p	q	s	b	k	e	a	w	j	l	h	Z				Bi	n
CUCT 201C	CUCT 201CE	12	16	10	51	32	19	51	12	76	89	96	32	21	61	62	31	12.7	UC 201	CT 204	1.2
CUCT 202C	CUCT 202CE	15	16	10	51	32	19	51	12	76	89	96	32	21	61	62	31	12.7	UC 202	CT 204	1.2
CUCT 203C	CUCT 203CE	17	16	10	51	32	19	51	12	76	89	96	32	21	61	62	31	12.7	UC 203	CT 204	1.2
CUCT 204C	CUCT 204CE	20	16	10	51	32	19	51	12	76	89	96	32	21	61	62	31	12.7	UC 204	CT 204	1.2
CUCT 205C	CUCT 205CE	25	16	10	51	32	19	51	12	76	89	100	32	24	62	70	34.1	14.3	UC 205	CT 205	1.5
CUCT 206C	CUCT 206CE	30	16	10	56	37	22	57	12	89	102	113	37	28	70	74	38.1	15.9	UC 206	CT 206	2.0
CUCT 207C	CUCT 207CE	35	16	13	64	37	22	64	12	89	102	129	37	30	78	80	42.9	17.5	UC 207	CT 207	2.6
CUCT 208C	CUCT 208CE	40	19	16	83	49	29	83	16	102	114	144	49	33	88	90	49.2	19	UC 208	CT 208	3.4
CUCT 209C	CUCT 209CE	45	19	16	83	49	29	83	16	102	117	145	49	35	87	90	49.2	19	UC 209	CT 209	3.6
CUCT 210C	CUCT 210CE	50	19	16	83	49	29	86	16	102	117	151	49	37	90	98	51.6	19	UC 210	CT 210	4.1
CUCT 211C	CUCT 211CE	55	25	19	102	64	35	95	22	130	146	174	64	38	106	100	55.6	22.2	UC 211	CT 211	5.6
CUCT 212C	CUCT 212CE	60	32	19	102	64	35	102	22	130	146	194	64	42	119	114	65.1	25.4	UC 212	CT 212	7.0
CUCT 213C	CUCT 213CE	65	32	21	111	70	41	121	26	151	167	224	70	44	137	118	65.1	25.4	UC 213	CT 213	9.2
CUCT 214C	CUCT 214CE	70	32	21	111	70	41	121	26	151	167	224	70	46	137	134	74.6	30.2	UC 214	CT 214	9.8
CUCT 215C	CUCT 215CE	75	32	21	111	70	41	121	26	151	167	232	70	48	140	136	77.8	33.3	UC 215	CT 215	10.2
CUCT 216C	CUCT 216CE	80	32	21	111	70	41	121	26	165	184	236	70	51	140	146	82.6	33.3	UC 216	CT 216	12.4
CUCT 217C	CUCT 217CE	85	38	29	124	73	48	157	30	173	198	264	73	54	162	150	85.7	34.1	UC 217	CT 217	15.4

TAKE-UP UNITS WITH PRESSED STEEL COVERS

UCT 200C (E) type

Normal Duty
Set-screw Locking

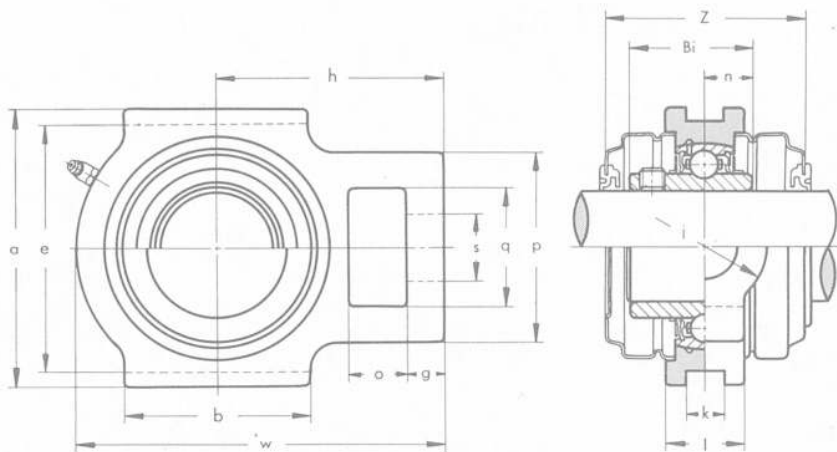

Unit No.		Shaft Diam. mm	Dimensions mm														Bearing No.	Housing No.	Weight kg		
Open Cover	Closed Cover		o	g	p	q	s	b	k	e	a	w	j	l	h	Z				Bi	n
UCT 201C	UCT 201E	12	16	10	51	32	19	51	12	76	89	94	32	21	61	56	31	12.7	UC 201	T 204C	0.85
UCT 202C	UCT 202E	15	16	10	51	32	19	51	12	76	89	94	32	21	61	56	31	12.7	UC 202	T 204C	0.83
UCT 203C	UCT 203E	17	16	10	51	32	19	51	12	76	89	94	32	21	61	56	31	12.7	UC 203	T 204C	0.82
UCT 204C	UCT 204E	20	16	10	51	32	19	51	12	76	89	94	32	21	61	56	31	12.7	UC 204	T 204C	0.80
UCT 205C	UCT 205E	25	16	10	51	32	19	51	12	76	89	97	32	24	62	63	34.1	14.3	UC 205	T 205C	0.89
UCT 206C	UCT 206E	30	16	10	56	37	22	57	12	89	102	113	37	28	70	65	38.1	15.9	UC 206	T 206C	1.4
UCT 207C	UCT 207E	35	16	13	64	37	22	64	12	89	102	129	37	30	78	70	42.9	17.5	UC 207	T 207C	1.8
UCT 208C	UCT 208E	40	19	16	83	49	29	83	16	102	114	144	49	33	88	82	49.2	19	UC 208	T 208C	2.5
UCT 209C	UCT 209E	45	19	16	83	49	29	83	16	102	117	144	49	35	87	82	49.2	19	UC 209	T 209C	2.6
UCT 210C	UCT 210E	50	19	16	83	49	29	86	16	102	117	149	49	37	90	87	51.6	19	UC 210	T 210C	2.8
UCT 211C	UCT 211E	55	25	19	102	64	35	95	22	130	146	171	64	38	106	88	55.6	22.2	UC 211	T 211C	4.3
UCT 212C	UCT 212E	60	32	19	102	64	35	102	22	130	146	194	64	42	119	102	65.1	25.4	UC 212	T 212C	5.5
UCT 213C	UCT 213E	65	32	21	111	70	41	121	26	151	167	224	70	44	137	102	65.1	25.4	UC 213	T 213C	7.5

TAKE-UP UNITS

BT 200 type

Light Duty
Set-screw Locking

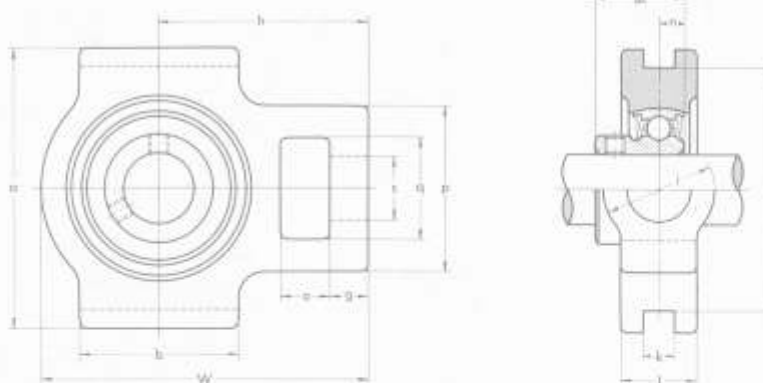

Unit No.	Shaft Diam. mm	Dimensions mm														Bearing No.	Housing No.	Weight kg	
		o	g	p	q	s	b	k	e	a	w	j	l	h	Bi				n
BT 204	20	16	10	51	32	19	51	12	76	89	94	32	21	61	24.7	7	8 4	T 204	0.70
BT 205	25	16	10	51	32	19	51	12	76	89	97	32	24	62	27	7.5	8 5	T 205	0.79
BT 206	30	16	10	56	37	22	57	12	89	102	113	37	28	70	30.3	8	8 6	T 206	1.2
BT 207	35	16	13	64	37	22	64	12	89	102	129	37	30	78	32.9	8.5	8 7	T 207	1.6

TAKE-UP UNITS WITH PRESSED STEEL FRAME

UCT 200+WB type

Normal Duty
Set-screw Locking

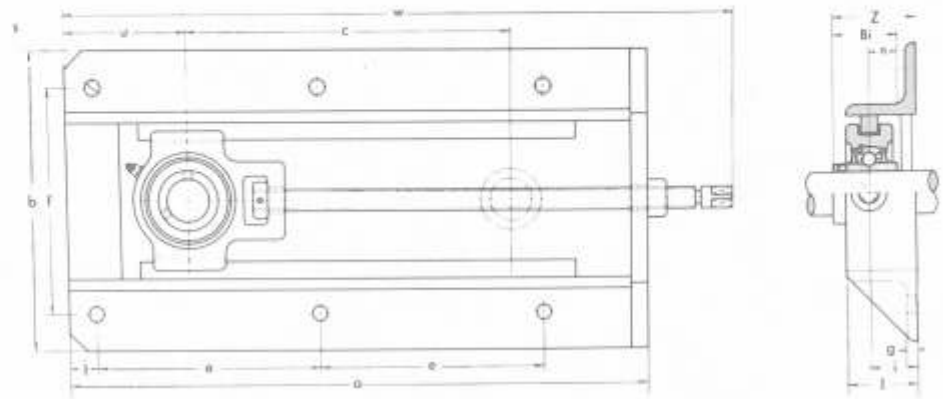

Unit No.	Shaft Diam. mm	Dimensions mm															Belt Size mm	Frame No.	Weight kg
		a	b	c	e	f	g	i	l	j	s	u	w	Z	Bi	n			
UCT 201+WB	12	317	199	150	117	154	6	29	50	19	12	83	367	47.3	31	12.7	M10	WB 205-150	5.0
UCT 202+WB	15	317	199	150	117	154	6	29	50	19	12	83	367	47.3	31	12.7	M10	WB 205-150	5.0
UCT 203+WB	17	317	199	150	117	154	6	29	50	19	12	83	367	47.3	31	12.7	M10	WB 205-150	5.0
UCT 204+WB	20	317	199	150	117	154	6	29	50	19	12	83	367	47.3	31	12.7	M10	WB 205-150	5.0
UCT 205+WB	25	317	199	150	117	154	6	29	50	19	12	83	368	48.7	34.1	14.3	M10	WB 205-150	5.0
UCT 206+WB	30	337	212	150	127	166	6	30	50	19	12	95	396	52.2	38.1	15.9	M10	WB 206-150	5.9
UCT 207+WB	35	429	212	230	173	166	6	30	50	19	12	99	490	55.4	42.9	17.5	M10	WB 207-230	7.9
UCT 208+WB	40	520	233	300	219	192	6	30	50	22	15	108	591	60.2	49.2	19	M12	WB 210-300	11.1
UCT 209+WB	45	520	233	300	219	192	6	30	50	22	15	108	590	60.2	49.2	19	M12	WB 210-300	11.1
UCT 210+WB	50	520	233	300	219	192	6	30	50	22	15	108	593	62.6	51.6	19	M12	WB 210-300	11.2
UCT 211+WB	55	542	301	300	230	240	6	38	65	22	15	114	631	71.4	55.6	22.2	M12	WB 211-300	17.3
UCT 212+WB	60	568	301	300	243	240	6	38	65	22	15	127	657	77.7	65.1	25.4	M12	WB 212-300	18.7
UCT 213+WB	65	606	322	300	260	260	6	38	65	22	15	144	699	77.7	65.1	25.4	M12	WB 213-300	23.4

TAKE-UP UNITS WITH FRAME

ASAHI

* UCTU 200+WU type

Normal Duty
Set-screw Locking

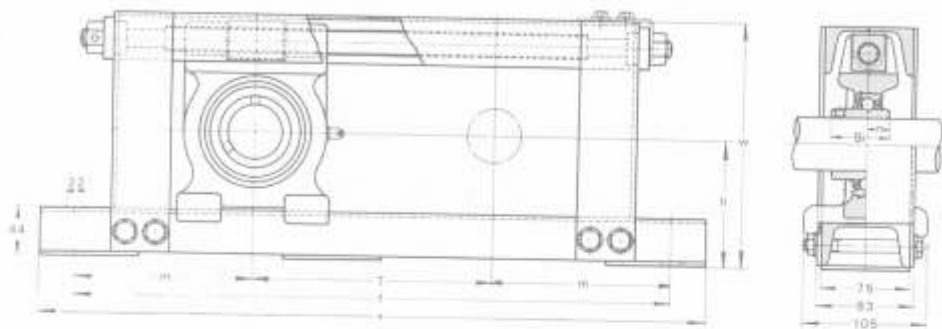

Unit No.	Shaft Diam. mm	Dimensions mm								Bolt Size mm	Bearing No.	Housing No.	Frame No.	Weight kg
		T	a	f	h	m	w	Bi	n					
UCTU 208+WU 500	40	500	870	810	97	155	190	49.2	19	M18	UC 208	TU 208	WU 208-500	19.0
UCTU 208+WU 600		600	970	910									WU 208-600	20.6
UCTU 208+WU 700		700	1070	1010									WU 208-700	22.2
UCTU 208+WU 800		800	1170	1110									WU 208-800	23.8
UCTU 208+WU 900		900	1270	1210									WU 208-900	25.3
UCTU 209+WU 500	45	500	880	820	102	160	200	49.2	19	M18	UC 209	TU 209	WU 209-500	19.7
UCTU 209+WU 600		600	980	920									WU 209-600	21.3
UCTU 209+WU 700		700	1080	1020									WU 209-700	22.9
UCTU 209+WU 800		800	1180	1120									WU 209-800	24.5
UCTU 209+WU 900		900	1280	1220									WU 209-900	26.1
UCTU 210+WU 500	50	500	890	830	107	165	210	51.6	19	M18	UC 210	TU 210	WU 210-500	20.5
UCTU 210+WU 600		600	990	930									WU 210-600	22.2
UCTU 210+WU 700		700	1090	1030									WU 210-700	23.8
UCTU 210+WU 800		800	1190	1130									WU 210-800	25.4
UCTU 210+WU 900		900	1290	1230									WU 210-900	27.0
UCTU 211+WU 500	55	500	910	850	115	175	230	55.6	22.2	M18	UC 211	TU 211	WU 211-500	22.4
UCTU 211+WU 600		600	1010	950									WU 211-600	23.7
UCTU 211+WU 700		700	1110	1050									WU 211-700	25.8
UCTU 211+WU 800		800	1210	1150									WU 211-800	27.4
UCTU 211+WU 900		900	1310	1250									WU 211-900	29.1
UCTU 212+WU 500	60	500	920	860	120	180	240	65.1	25.4	M18	UC 212	TU 212	WU 212-500	23.9
UCTU 212+WU 600		600	1020	960									WU 212-600	25.6
UCTU 212+WU 700		700	1120	1060									WU 212-700	27.2
UCTU 212+WU 800		800	1220	1160									WU 212-800	28.9
UCTU 212+WU 900		900	1320	1260									WU 212-900	30.6

TAKE-UP UNITS WITH FRAME

* UCTL 200+WL type

Normal Duty
Set-screw Locking

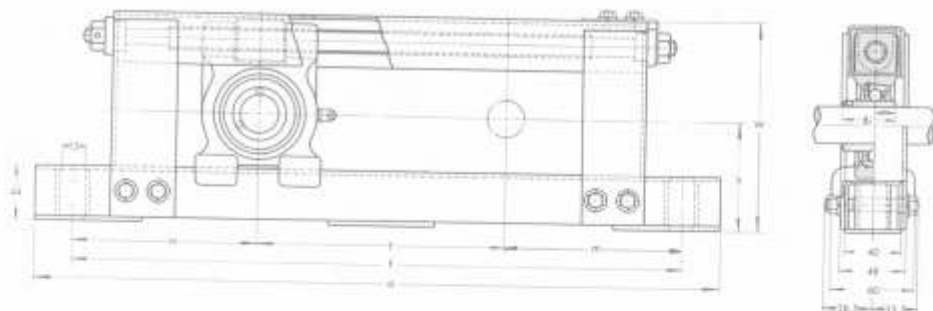

Unit No.	Shaft Diam. mm	Dimensions mm								Bolt Size mm	Bearing No.	Housing No.	Frame No.	Weight kg
		T	a	f	h	m	w	Bi	n					
UCTL 204+WL 100	20	100	430	370	77	135	146	31	12.7	M12	UC 204	TL 204	WL 204-100	5.6
UCTL 204+WL 200		200	530	470									WL 204-200	6.3
UCTL 204+WL 300		300	630	570									WL 204-300	7.0
UCTL 204+WL 400		400	730	670									WL 204-400	7.7
UCTL 205+WL 100	25	100	440	380	82	140	156	34.1	14.3	M12	UC 205	TL 205	WL 205-100	6.0
UCTL 205+WL 200		200	540	480									WL 205-200	6.7
UCTL 205+WL 300		300	640	580									WL 205-300	7.4
UCTL 205+WL 400		400	740	680									WL 205-400	8.1
UCTL 206+WL 100	30	100	450	390	87	145	166	38.1	15.9	M12	UC 206	TL 206	WL 206-100	6.5
UCTL 206+WL 200		200	550	490									WL 206-200	7.2
UCTL 206+WL 300		300	650	590									WL 206-300	7.9
UCTL 206+WL 400		400	750	690									WL 206-400	8.6
UCTL 207+WL 100	35	100	460	400	92	150	176	42.9	17.5	M12	UC 207	TL 207	WL 207-100	7.1
UCTL 207+WL 200		200	560	500									WL 207-200	7.8
UCTL 207+WL 300		300	660	600									WL 207-300	8.5
UCTL 207+WL 400		400	760	700									WL 207-400	9.2
UCTL 208+WL 100	40	100	470	410	97	155	186	49.2	19	M12	UC 208	TL 208	WL 208-100	7.8
UCTL 208+WL 200		200	570	510									WL 208-200	8.5
UCTL 208+WL 300		300	670	610									WL 208-300	9.2
UCTL 208+WL 400		400	770	710									WL 208-400	9.9
UCTL 209+WL 100	45	100	480	420	100	160	192	49.2	19	M12	UC 209	TL 209	WL 209-100	8.2
UCTL 209+WL 200		200	580	520									WL 209-200	8.9
UCTL 209+WL 300		300	680	620									WL 209-300	9.6
UCTL 209+WL 400		400	780	720									WL 209-400	10.3

CARTRIDGE UNITS

UCC 200 type

Normal Duty
Set-screw Locking

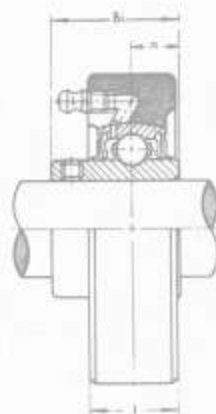
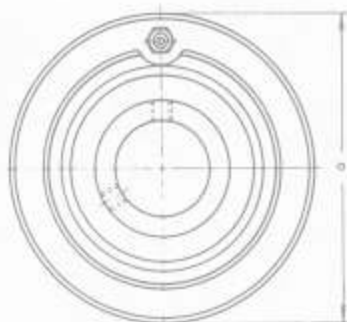

Unit No.	Shaft Diam. mm	Dimensions mm				Bearing No.	Housing No.	Weight kg
		a	l	Bi	n			
UCC 201	12	72	20	31	12.7	UC 201	C 204	0.54
UCC 202	15	72	20	31	12.7	UC 202	C 204	0.52
UCC 203	17	72	20	31	12.7	UC 203	C 204	0.51
UCC 204	20	72	20	31	12.7	UC 204	C 204	0.49
UCC 205	25	80	22	34.1	14.3	UC 205	C 205	0.65
UCC 206	30	85	27	38.1	15.9	UC 206	C 206	0.82
UCC 207	35	90	28	42.9	17.5	UC 207	C 207	0.93
UCC 208	40	100	30	49.2	19	UC 208	C 208	1.2
UCC 209	45	110	31	49.2	19	UC 209	C 209	1.5
UCC 210	50	120	33	51.6	19	UC 210	C 210	1.9
UCC 211	55	125	35	55.6	22.2	UC 211	C 211	2.1
UCC 212	60	130	38	65.1	25.4	UC 212	C 212	2.5
UCC 213	65	140	40	65.1	25.4	UC 213	C 213	3.0

CARTRIDGE UNITS

* UCLC 200 type

Normal Duty
Set-screw Locking

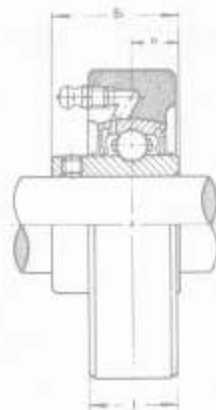
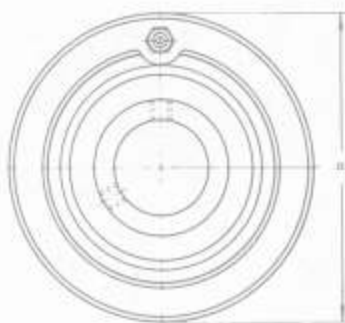

Unit No.	Shaft Diam. mm	Dimensions mm				Bearing No.	Housing No.	Weight kg
		a	l	Bi	n			
UCLC 201	12	68.26	22.22	26	10	UCW 201	LC 203	0.51
UCLC 202	15	68.26	22.22	26	10	UCW 202	LC 203	0.50
UCLC 203	17	68.26	22.22	26	10	UCW 203	LC 203	0.49
UCLC 204	20	74.61	22.22	31	12.7	UC 204	LC 204	0.58
UCLC 205	25	79.38	26.19	34.1	14.3	UC 205	LC 205	0.73
UCLC 206	30	88.90	27.78	38.1	15.9	UC 206	LC 206	0.95
UCLC 207	35	98.42	30.96	42.9	17.5	UC 207	LC 207	1.2
UCLC 208	40	106.36	37.31	49.2	19	UC 208	LC 208	1.7
UCLC 209	45	111.12	36.51	49.2	19	UC 209	LC 209	1.7
UCLC 210	50	115.89	37.31	51.6	19	UC 210	LC 210	1.9
UCLC 211	55	125.41	40.48	55.6	22.2	UC 211	LC 211	2.4
UCLC 212	60	149.22	41.28	65.1	25.4	UC 212	LC 212	3.8
UCLC 213	65	149.22	41.28	65.1	25.4	UC 213	LC 213	3.6

CARTRIDGE UNITS

*** UCC X00 type**

Medium Duty
Set-screw Locking

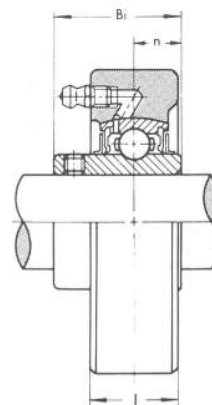
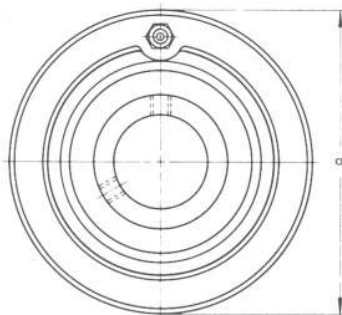

Unit No.	Shaft Diam. mm	Dimensions mm				Bearing No.	Housing No.	Weight kg
		a	l	Bi	n			
UCC X05	25	90	27	38.1	15.9	UC X05	C X05	1.0
UCC X06	30	100	30	42.9	17.5	UC X06	C X06	1.3
UCC X07	35	110	34	49.2	19	UC X07	C X07	1.9
UCC X08	40	120	38	49.2	19	UC X08	C X08	2.3
UCC X09	45	120	38	51.6	19	UC X09	C X09	2.3
UCC X10	50	130	40	55.6	22.2	UC X10	C X10	2.8
UCC X11	55	150	42	65.1	25.4	UC X11	C X11	4.7
UCC X12	60	160	44	65.1	25.4	UC X12	C X12	5.1

CARTRIDGE UNITS

*** UCC 300 type**

Heavy Duty
Set-screw Locking

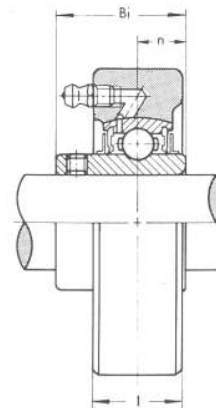
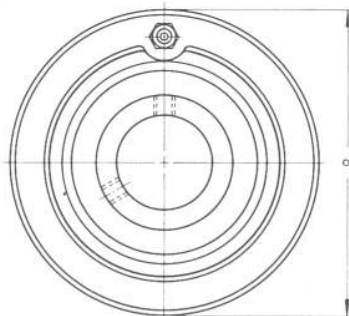

Unit No.	Shaft Diam. mm	Dimensions mm				Bearing No.	Housing No.	Weight kg
		a	l	Bi	n			
UCC 305	25	90	26	38	15	UC 305	C 305	1.1
UCC 306	30	100	28	43	17	UC 306	C 306	1.3
UCC 307	35	110	32	48	19	UC 307	C 307	1.8
UCC 308	40	120	34	52	19	UC 308	C 308	2.2
UCC 309	45	130	38	57	22	UC 309	C 309	2.7
UCC 310	50	140	40	61	22	UC 310	C 310	3.3
UCC 311	55	150	44	66	25	UC 311	C 311	3.9
UCC 312	60	160	46	71	26	UC 312	C 312	4.8
UCC 313	65	170	50	75	30	UC 313	C 313	5.7
UCC 314	70	180	52	78	33	UC 314	C 314	6.6
UCC 315	75	190	55	82	32	UC 315	C 315	7.7
UCC 316	80	200	60	86	34	UC 316	C 316	8.9
UCC 317	85	215	64	96	40	UC 317	C 317	11.2
UCC 318	90	225	66	96	40	UC 318	C 318	12.3
UCC 319	95	240	72	103	41	UC 319	C 319	15.2
UCC 320	100	260	75	108	42	UC 320	C 320	19.2
UCC 321	105	260	75	112	44	UC 321	C 321	18.9
UCC 322	110	300	80	117	46	UC 322	C 322	28.1
UCC 324	120	320	90	126	51	UC 324	C 324	35.0
UCC 326	130	340	100	135	54	UC 326	C 326	42.2
UCC 328	140	360	100	145	59	UC 328	C 328	48.9

HANGER BEARING UNITS

UCECH 200 type

Normal Duty
Set-screw Locking

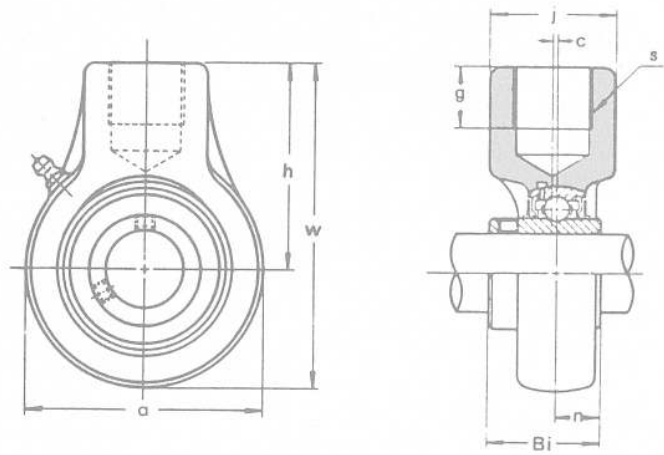

Unit No.	Shaft Diam. mm	Dimensions mm										Bearing No.	Housing No.	Weight kg
		a	w	h	j	s	g	Bi	n	c				
UCECH 205	25	70	99	64	40	PF 3/4	19	34.1	14.3	0	UC 205	ECH 205	0.74	
UCECH 206	30	80	104	64	40	PF 3/4	19	38.1	15.9	0	UC 206	ECH 206	0.91	
UCECH 207	35	92	116	70	40	PF 3/4	19	42.9	17.5	0	UC 207	ECH 207	1.2	
UCECH 208	40	96	121	73	40	PF 3/4	19	49.2	19	2	UC 208	ECH 208	1.4	
UCECH 209	45	108	136	82	48	PF 1	21	49.2	19	4	UC 209	ECH 209	1.8	
UCECH 210	50	114	140	83	48	PF 1	21	51.6	19	5	UC 210	ECH 210	1.9	

TWO-BOLT FLANGE UNITS

BLCTE 200K type

Light Duty
Set-screw Locking

KHLCTE 200K type incorporating bearing with eccentric locking collar also available.

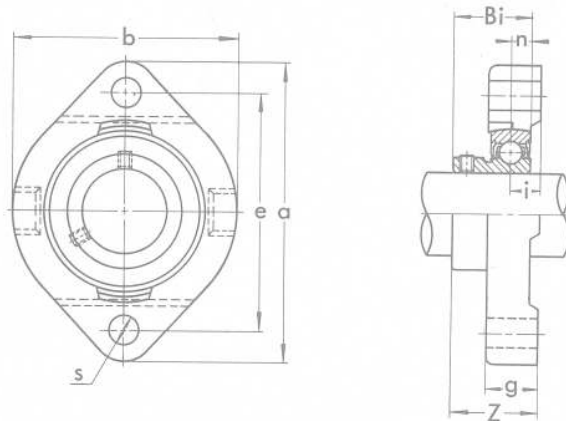

Unit No.	Shaft Diam. mm	Dimensions mm									Bolt Size mm	Bearing No.	Housing No.	Weight kg
		a	e	i	g	s	b	Z	Bi	n				
BLCTE 201K	12	81	63.5	8.5	15	7	59	24.5	22	6	M 6	B 1	LCTE 203K	0.22
BLCTE 202K	15	81	63.5	8.5	15	7	59	24.5	22	6	M 6	B 2	LCTE 203K	0.22
BLCTE 203K	17	81	63.5	8.5	15	7	59	24.5	22	6	M 6	B 3	LCTE 203K	0.22
BLCTE 204K	20	90	71.4	9.5	17	10	67	27.2	24.7	7	M 8	B 4	LCTE 204K	0.40
BLCTE 205K	25	97	76.2	10	17.5	10	71	29.5	27	7.5	M 8	B 5	LCTE 205K	0.49
BLCTE 206K	30	113	90.5	11.5	20.5	12	84	33.8	30.3	8	M10	B 6	LCTE 206K	0.77
BLCTE 207K	35	126	100	12.5	22	12	94	36.9	32.9	8.5	M10	B 7	LCTE 207K	0.98



BALL BEARINGS

UC 200 type

Normal Duty
Set-screw Locking

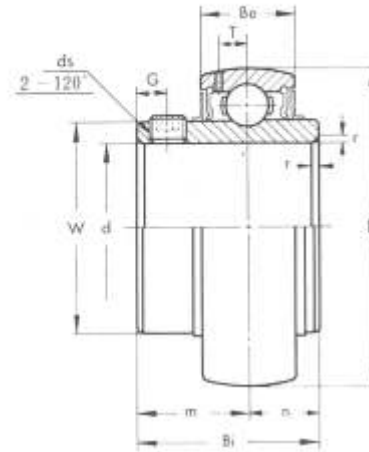

(Metric series)

Bearing No.	Dimensions mm											Basic Load Rating kg		Weight kg
	d	D	Bi	Be	r	n	m	G	ds	T	W	Dynamic C	Static Co	
UC 201	12	47	31	17	1	12.7	18.3	4.5	M6×0.75	4.5	29	1310	630	0.21
UC 202	15	47	31	17	1	12.7	18.3	4.5	M6×0.75	4.5	29	1310	630	0.19
UC 203	17	47	31	17	1	12.7	18.3	4.5	M6×0.75	4.5	29	1310	630	0.18
UC 204	20	47	31	17	1.5	12.7	18.3	4.5	M6×0.75	4.5	29	1310	630	0.16
UC 205	25	52	34.1	17	1.5	14.3	19.8	5	M6×0.75	4.5	34	1430	710	0.19
UC 206	30	62	38.1	19	1.5	15.9	22.2	5	M6×0.75	5.1	40.5	2000	1020	0.31
UC 207	35	72	42.9	20	2	17.5	25.4	6	M8×1	5.8	48	2640	1400	0.48
UC 208	40	80	49.2	21	2	19	30.2	8	M8×1	6.2	53	2990	1600	0.62
UC 209	45	85	49.2	22	2	19	30.2	8	M8×1	6.5	57.3	3350	1810	0.67
UC 210	50	90	51.6	23	2	19	32.6	9	M10×1.25	6.5	63	3600	2010	0.78
UC 211	55	100	55.6	24	2.5	22.2	33.4	9	M10×1.25	7.3	70	4400	2550	1.03
UC 212	60	110	65.1	26	2.5	25.4	39.7	10	M10×1.25	7.7	77	5350	3150	1.45
UC 213	65	120	65.1	27	2.5	25.4	39.7	10	M10×1.25	8.3	82.1	5850	3500	1.71
UC 214	70	125	74.6	29	2.5	30.2	44.4	12	M12×1.5	8.7	87	6350	3800	2.06
UC 215	75	130	77.8	30	2.5	33.3	44.5	14	M12×1.5	9.2	91.5	6750	4200	2.22
UC 216	80	140	82.6	32	3	33.3	49.3	14	M12×1.5	9.6	98.5	7400	4550	2.82
UC 217	85	150	85.7	34	3	34.1	51.6	14	M12×1.5	10.5	105	8500	5500	3.38
UC 218	90	160	96	36	3	39.7	56.3	15	M12×1.5	11.1	111.5	9750	6300	4.34

(Inch series)

Bearing No.	Dimensions in.											Basic Load Rating lb.		Weight lb.	
	d	D	Bi	Be	r	n	m	G	ds(UNF)	T	W	Dynamic C	Static Co		
UC 201-8	1/2														0.46
* UC 202-9	5/8	1.8504	1.220	0.669	0.039	0.500	0.720	0.177	1/4-28	0.177	1.142	2890	1390	0.42	
UC 202-10	3/4														
* UC 203-11	3/4	1.8504	1.220	0.669	0.059	0.500	0.720	0.177	1/4-28	0.177	1.142	2890	1390	0.35	
UC 204-12	7/8														
* UC 205-14	7/8	2.0472	1.342	0.669	0.059	0.563	0.780	0.197	1/4-28	0.177	1.339	3150	1560	0.42	
UC 205-15	1														
UC 205-16	1 1/8														
* UC 206-17	1 1/8	2.4409	1.500	0.748	0.059	0.626	0.874	0.197	1/4-28	0.201	1.594	4410	2250	0.68	
UC 206-18	1 1/4														
UC 206-19	1 3/8														
UC 207-20	1 1/4	2.8346	1.689	0.787	0.079	0.689	1.000	0.236	5/16-24	0.228	1.890	5820	3090	1.06	
UC 207-21	1 3/8														
UC 207-22	1 3/8														
UC 207-23	1 7/8														
* UC 208-24	1 1/2	3.1496	1.937	0.827	0.079	0.748	1.189	0.315	5/8-24	0.244	2.087	6590	3530	1.37	
UC 208-25	1 5/8														
UC 209-26	1 5/8	3.3465	1.937	0.866	0.079	0.748	1.189	0.315	5/8-24	0.256	2.256	7390	3990	1.48	
UC 209-27	1 7/8														
UC 209-28	1 3/4														
UC 210-30	1 7/8	3.5433	2.031	0.906	0.079	0.748	1.283	0.354	3/8-24	0.256	2.480	7940	4430	1.72	
UC 210-31	1 5/8														
* UC 211-32	2	3.9370	2.189	0.945	0.098	0.874	1.315	0.354	3/8-24	0.287	2.756	9700	5620	2.27	
UC 211-34	2 1/8														
UC 211-35	2 3/8														
UC 212-36	2 1/4	4.3307	2.563	1.024	0.098	1.000	1.563	0.394	7/8-24	0.303	3.031	11800	6940	3.20	
UC 212-38	2 3/8														
UC 212-39	2 7/8														
UC 213-40	2 1/2	4.7244	2.563	1.063	0.098	1.000	1.563	0.394	3/8-24	0.327	3.232	12900	7720	3.77	
* UC 214-44	2 3/4	4.9213	2.937	1.142	0.098	1.189	1.748	0.472	7/8-20	0.343	3.425	14000	8380	4.54	
* UC 215-48	3	5.1181	3.063	1.181	0.098	1.311	1.752	0.551	7/8-20	0.362	3.602	14900	9260	4.89	
* UC 216-50	3 1/8	5.5118	3.252	1.260	0.118	1.311	1.941	0.551	7/8-20	0.378	3.878	16300	10000	6.22	
* UC 217-52	3 1/4	5.9055	3.374	1.339	0.118	1.343	2.031	0.551	7/8-20	0.413	4.134	18700	12100	7.45	
* UC 218-56	3 1/2	6.2992	3.780	1.417	0.118	1.563	2.217	0.591	1 1/2-20	0.437	4.390	21500	13900	9.57	

BALL BEARINGS

*** UCW 200 type**

Normal Duty
Set-screw Locking

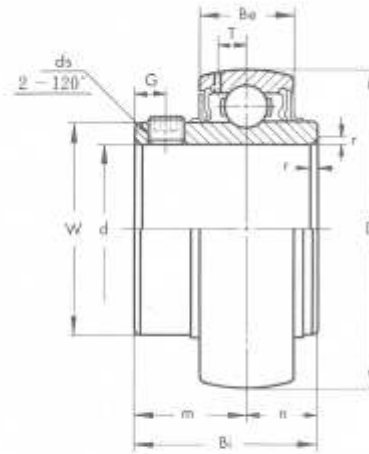

《Metric series》

Bearing No.	Dimensions mm											Basic Load Rating kg		Weight kg
	d	D	Bi	Be	r	n	m	G	ds	T	W	Dynamic C	Static Co	
UCW 201	12	40	26	15	1	10	16	4	M 5×0.8	4	24.7	750	455	0.12
UCW 202	15	40	26	15	1	10	16	4	M 5×0.8	4	24.7	750	455	0.11
UCW 203	17	40	26	15	1	10	16	4	M 5×0.8	4	24.7	750	455	0.10

《Inch series》

Bearing No.	Dimensions in.											Basic Load Rating lb.		Weight lb.
	d	D	Bi	Be	r	n	m	G	ds (UNF)	T	W	Dynamic C	Static Co	
UCW 201-8	1/2	1.5748	1.024	0.591	0.039	0.394	0.630	0.157	10-32	0.157	0.972	1650	1000	0.26
UCW 202-9	9/16													0.24
UCW 202-10	5/8													0.22
UCW 203-11	11/16													

BALL BEARINGS

UC X00 type

Medium Duty
Set-screw Locking

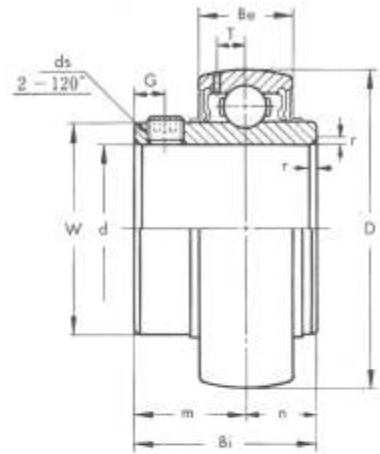

《Metric series》

Bearing No.	Dimensions mm											Basic Load Rating kg		Weight kg
	d	D	Bi	Be	r	n	m	G	ds	T	W	Dynamic C	Static Co	
UC X05	25	62	38.1	19	1.5	15.9	22.2	5	M 6×0.75	5.1	40.5	2000	1020	0.37
UC X06	30	72	42.9	20	1.5	17.5	25.4	6	M 8×1	5.8	48	2640	1400	0.46
UC X07	35	80	49.2	21	2	19	30.2	8	M 8×1	6.2	53	2990	1600	0.74
UC X08	40	85	49.2	22	2	19	30.2	8	M 8×1	6.5	57.3	3350	1810	0.80
UC X09	45	90	51.6	23	2	19	32.6	9	M10×1.25	6.5	63	3600	2010	0.92
UC X10	50	100	55.6	24	2	22.2	33.4	9	M10×1.25	7.3	70	4400	2550	1.21
UC X11	55	110	65.1	26	2.5	25.4	39.7	10	M10×1.25	7.7	77	5350	3150	1.72
UC X12	60	120	65.1	27	2.5	25.4	39.7	10	M10×1.25	8.3	82.1	5850	3500	1.97
UC X13	65	125	74.6	29	2.5	30.2	44.4	12	M12×1.5	8.7	87	6350	3800	2.33
UC X14	70	130	77.8	30	2.5	33.3	44.5	12	M12×1.5	9.2	91.5	6750	4200	2.57
UC X15	75	140	82.6	32	2.5	33.3	49.3	12	M12×1.5	9.6	98.5	7400	4550	3.22
UC X16	80	150	85.7	34	3	34.1	51.6	12	M12×1.5	10.5	105	8500	5500	3.81
UC X17	85	160	96	36	3	39.7	56.3	12	M12×1.5	11.1	111.5	9750	6300	4.83
UC X18	90	170	104	38	3	42.9	61.1	14	M14×1.5	11.9	118	11100	7100	5.49
UC X20	100	190	117.5	42	3.5	49.2	68.3	16	M16×1.5	13	132.5	13700	9100	9.04

《Inch series》

Bearing No.	Dimensions in.											Basic Load Rating lb.		Weight lb.			
	d	D	Bi	Be	r	n	m	G	ds(UNF)	T	W	Dynamic C	Static Co				
* UC X05-14	7/8																
* X05-15	15/16	2.4409	1.500	0.748	0.059	0.626	0.874	0.197	1/4-28	0.201	1.594	4410	2250	0.82			
* X05-16	1																
* UC X06-18	1 1/8																
* X06-19	1 3/8	2.8346	1.689	0.787	0.059	0.689	1.000	0.236	5/16-24	0.228	1.890	5820	3090	1.01			
* X06-20	1 1/4																
* UC X07-22	1 3/8																
* X07-23	1 7/8	3.1496	1.937	0.827	0.079	0.748	1.189	0.315	3/8-24	0.244	2.087	6590	3530	1.63			
UC X08-24	1 1/2	3.3465	1.937	0.866	0.079	0.748	1.189	0.315	5/8-24	0.256	2.256	7390	3990	1.76			
* UC X09-26	1 5/8																
* X09-27	1 7/8	3.5433	2.031	0.906	0.079	0.748	1.283	0.354	3/4-24	0.256	2.480	7940	4430	2.03			
* X09-28	1 3/4																
* UC X10-30	1 7/8																
* X10-31	1 3/4	3.9370	2.189	0.945	0.079	0.874	1.315	0.354	3/4-24	0.287	2.746	9700	5620	2.67			
* X10-32	2																
* UC X11-34	2 1/8																
* X11-35	2 3/8	4.3307	2.563	1.024	0.098	1.000	1.563	0.394	3/4-24	0.303	3.031	11800	6940	3.79			
* X11-36	2 1/4																
* UC X12-38	2 3/8																
* X12-39	2 7/8	4.7244	2.563	1.063	0.098	1.000	1.563	0.394	3/4-24	0.327	3.232	12900	7720	4.34			
UC X13-40	2 1/2	4.9213	2.937	1.142	0.098	1.189	1.748	0.472	7/8-20	0.343	3.425	14000	8380	5.14			
UC X14-43	2 5/8																
X14-44	2 3/4	5.1181	3.063	1.181	0.098	1.311	1.752	0.472	7/8-20	0.362	3.602	14900	9260	5.66			
UC X15-47	2 7/8																
X15-48	3	5.5118	3.252	1.260	0.098	1.311	1.941	0.472	7/8-20	0.378	3.878	16300	10000	7.10			
* UC X16-51	3 1/8	5.9055	3.374	1.339	0.118	1.343	2.031	0.472	7/8-20	0.413	4.134	18700	12100	8.40			
UC X17-52	3 1/4																
X17-55	3 3/8	6.2992	3.780	1.417	0.118	1.563	2.217	0.472	1 1/2-20	0.437	4.390	21500	13900	10.65			
UC X18-56	3 1/2	6.6929	4.094	1.496	0.118	1.689	2.406	0.551	1 1/2-18	0.469	4.646	24500	15700	12.10			
UC X20-63	3 3/4																
X20-64	4	7.4803	4.626	1.654	0.138	1.937	2.689	0.630	5/8-18	0.512	5.217	30200	20100	19.92			

UC 300 type

Heavy Duty
Set-screw Locking

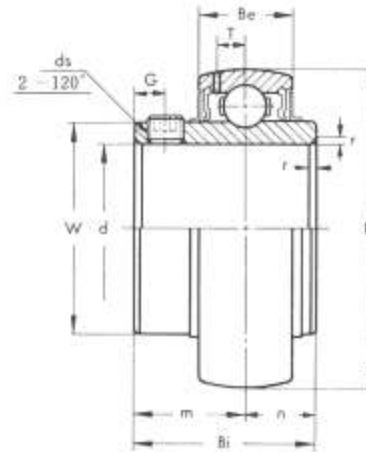

《Metric series》

Bearing No.	Dimensions mm											Basic Load Rating kg		Weight kg
	d	D	Bi	Be	r	n	m	G	ds	T	W	Dynamic C	Static Co	
UC 305	25	62	38	21	2	15	23	6	M 6×0.75	6.1	36.9	2170	1090	0.44
UC 306	30	72	43	23	2	17	26	6	M 6×0.75	6.7	45	2730	1420	0.56
UC 307	35	80	48	25	2.5	19	29	8	M 8×1	7.4	50.5	3400	1820	0.71
UC 308	40	90	52	27	2.5	19	33	10	M10×1.25	8.2	56	4150	2270	1.00
UC 309	45	100	57	30	2.5	22	35	10	M10×1.25	9	63	5250	3050	1.28
UC 310	50	110	61	32	3	22	39	12	M12×1.5	10	70.5	6300	3650	1.65
UC 311	55	120	66	34	3	25	41	12	M12×1.5	10.7	76.5	7300	4250	2.07
UC 312	60	130	71	36	3.5	26	45	12	M12×1.5	11.5	82.5	8300	4900	2.59
UC 313	65	140	75	38	3.5	30	45	12	M12×1.5	12.2	88.5	9450	5650	3.15
UC 314	70	150	78	40	3.5	33	45	12	M12×1.5	13	95.2	10600	6450	3.83
UC 315	75	160	82	42	3.5	32	50	14	M14×1.5	13.8	101.5	11600	7200	4.59
UC 316	80	170	86	44	3.5	34	52	14	M14×1.5	14.5	108	12500	8150	5.40
UC 317	85	180	96	46	4	40	56	16	M16×1.5	15	114.5	13500	9100	6.58
UC 318	90	190	96	48	4	40	56	16	M16×1.5	15.9	121	14600	10100	7.34
UC 319	95	200	103	50	4	41	62	16	M16×1.5	16.7	127.5	15600	11100	8.70
UC 320	100	215	108	54	4	42	66	18	M18×1.5	18	135.5	17700	13300	10.80
UC 321	105	225	112	56	4	44	68	18	M18×1.5	19	142	18700	14500	12.20
UC 322	110	240	117	60	4	46	71	18	M18×1.5	21	152	20900	17000	14.30
UC 324	120	260	126	64	4	51	75	18	M18×1.5	22	165	21100	17000	18.50
UC 326	130	280	135	68	5	54	81	20	M20×1.5	23	178	23400	19600	23.00
UC 328	140	300	145	73	5	59	86	20	M20×1.5	25	191.5	26000	22400	28.50

* 《Inch series》

Bearing No.	Dimensions in.											Basic Load Rating lb.		Weight lb.
	d	D	Bi	Be	r	n	m	G	ds(UNF)	T	W	Dynamic C	Static Co	
UC 305-14 305-16	1 1/8	2.4409	1.496	0.827	0.079	0.591	0.906	0.236	1/4-28	0.240	1.453	4780	2400	0.97
UC 306-18	1 1/8	2.8346	1.693	0.906	0.079	0.669	1.024	0.236	1/4-28	0.264	1.772	6020	3130	1.23
UC 307-20 307-22	1 1/4	3.1496	1.890	0.984	0.098	0.748	1.142	0.315	5/16-24	0.291	1.988	7500	4010	1.56
UC 308-24	1 1/2	3.5433	2.047	1.063	0.098	0.748	1.299	0.394	3/8-24	0.323	2.205	9150	5000	2.20
UC 309-26 309-28	1 5/8	3.9370	2.244	1.181	0.098	0.866	1.378	0.394	3/8-24	0.354	2.480	11570	6720	2.82
UC 310-30	1 3/4	4.3307	2.402	1.260	0.118	0.866	1.535	0.472	7/16-20	0.394	2.776	13900	8050	3.64
UC 311-32 311-34	2	4.7244	2.598	1.339	0.118	0.984	1.614	0.472	7/16-20	0.421	3.012	16100	9370	4.56
UC 312-36 312-38	2 1/8	5.1181	2.795	1.417	0.138	1.024	1.772	0.472	1/2-20	0.453	3.248	18300	10800	5.71
UC 313-40	2 1/8	5.5118	2.953	1.496	0.138	1.181	1.772	0.472	1/2-20	0.480	3.484	20800	12500	6.94
UC 314-44	2 3/4	5.9055	3.071	1.575	0.138	1.299	1.772	0.472	1/2-20	0.512	3.748	23400	14200	8.44
UC 315-48	3	6.2992	3.228	1.654	0.138	1.260	1.969	0.551	9/16-18	0.543	3.996	25600	15900	10.12
UC 316-50	3 1/8	6.6929	3.386	1.732	0.138	1.339	2.047	0.551	9/16-18	0.571	4.252	27600	18000	11.90
UC 317-52	3 1/4	7.0866	3.780	1.811	0.157	1.575	2.205	0.630	5/8-18	0.591	4.508	29800	20100	14.50
UC 318-56	3 1/2	7.4803	3.780	1.890	0.157	1.575	2.205	0.630	5/8-18	0.626	4.764	32200	22300	16.18
UC 319-60	3 3/4	7.8740	4.055	1.969	0.157	1.614	2.441	0.630	5/8-18	0.657	5.020	34400	24500	19.17
UC 320-64	4	8.4646	4.252	2.126	0.157	1.654	2.598	0.709	3/4-16	0.709	5.335	39000	29300	23.80

BALL BEARINGS

UK 200+H type

Normal Duty
Adapter Sleeve Locking

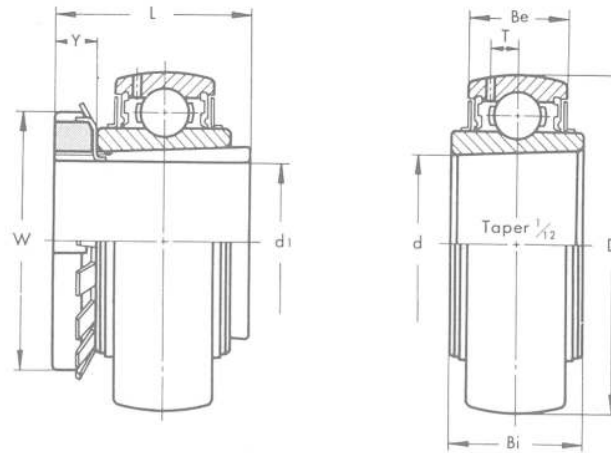

《Metric series》

Bearing No.	Dimensions mm										Basic Load Rating kg		Weight kg
	d ₁	D	L	d	Bi	Be	T	Y	W	Dynamic C	Static C ₀		
UK 205 +H 2305	20	52	35	25	23	17	4.5	8	38	1430	710	0.24	
UK 206 +H 2306	25	62	38	30	26	19	5.1	8	45	2000	1020	0.40	
UK 207 +H 2307	30	72	43	35	27	20	5.8	9	52	2640	1400	0.53	
UK 208 +H 2308	35	80	46	40	29	21	6.2	10	58	2990	1600	0.69	
UK 209 +H 2309	40	85	50	45	30	22	6.5	11	65	3350	1810	0.77	
UK 210 +H 2310	45	90	55	50	31	23	6.5	12	70	3600	2010	0.93	
UK 211 +H 2311	50	100	59	55	33	24	7.3	12	75	4400	2550	1.16	
UK 212 +H 2312	55	110	62	60	36	26	7.7	13	80	5350	3150	1.47	
UK 213 +H 2313	60	120	65	65	38	27	8.3	14	85	5850	3500	1.82	
UK 215 +H 2315	65	130	73	75	41	30	9.2	15	98	6750	4200	2.59	
UK 216 +H 2316	70	140	78	80	44	32	9.6	17	105	7400	4550	3.27	
UK 217 +H 2317	75	150	82	85	46	34	10.5	18	110	8500	5500	3.92	
UK 218 +H 2318	80	160	86	90	49	36	11.1	18	120	9750	6300	4.68	

《Inch series》

Bearing No.	Dimensions in.										Basic Load Rating lb.		Weight lb.
	d ₁	D	L	d	Bi	Be	T	Y	W	Dynamic C	Static C ₀		
UK 205 +HE 2305 205 +HA 2305	3/4 1 1/16	2.0472	1.378	0.9843	0.906	0.669	0.177	0.315	1.496	3150	1560	0.53	
UK 206 +HS 2306 206 +HA 2306 206 +HE 2306	7/8 1	2.4409	1.496	1.1811	1.024	0.748	0.201	0.315	1.772	4410	2250	0.88	
UK 207 +HS 2307 207 +HA 2307	1 1/8 1 3/16	2.8346	1.693	1.3780	1.063	0.787	0.228	0.354	2.047	5820	3090	1.17	
UK 208 +HE 2308 208 +HA 2308 208 +HS 2308	1 1/4 1 5/8 1 3/8	3.1496	1.811	1.5748	1.142	0.827	0.244	0.394	2.283	6590	3530	1.52	
UK 209 +HA 2309 209 +HE 2309 209 +HS 2309	1 7/16 1 1/2 1 5/8	3.3465	1.969	1.7717	1.181	0.866	0.256	0.433	2.559	7390	3990	1.70	
UK 210 +HA 2310 210 +HE 2310	1 1/2 1 3/4	3.5433	2.165	1.9685	1.220	0.906	0.256	0.472	2.756	7940	4430	2.05	
UK 211 +HS 2311 211 +HA 2311 211 +HE 2311	1 7/8 1 5/8 2	3.9370	2.323	2.1654	1.299	0.945	0.287	0.472	2.953	9700	5620	2.56	
UK 212 +HA 2312 212 +HS 2312	2 1/16 2 1/8	4.3307	2.441	2.3622	1.417	1.024	0.303	0.512	3.150	11800	6940	3.24	
UK 213 +HA 2313 213 +HE 2313 213 +HS 2313	2 3/16 2 1/4 2 3/8	4.7244	2.559	2.5591	1.496	1.063	0.327	0.551	3.346	12900	7720	4.01	
UK 215 +HE 2315	2 1/2	5.1181	2.874	2.9528	1.614	1.181	0.362	0.591	3.858	14900	9260	5.71	
UK 216 +HE 2316	2 3/4	5.5118	3.071	3.1496	1.732	1.260	0.378	0.669	4.134	16300	10000	7.21	
UK 217 +HE 2317	3	5.9055	3.228	3.3465	1.811	1.339	0.413	0.709	4.331	18700	12100	8.64	
UK 218 +HS 2318	3 1/8	6.2992	3.386	3.5433	1.929	1.417	0.437	0.709	4.724	21500	13900	10.31	

BALL BEARINGS

UK X00 +H type

Medium Duty
Adapter Sleeve Locking

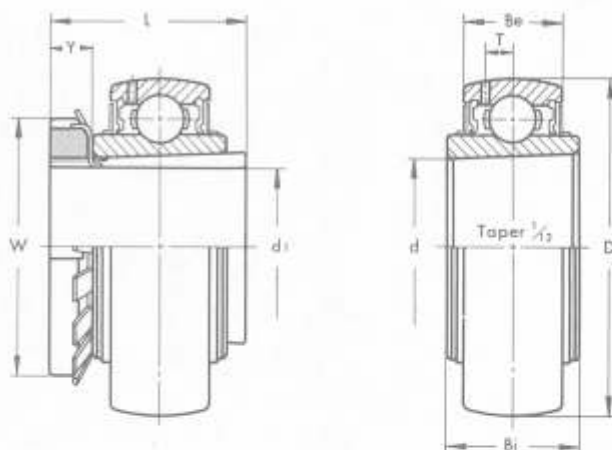

《Metric series》

Bearing No.	Dimensions mm										Basic Load Rating kg		Weight kg
	d ₁	D	L	d	B _i	B _e	T	Y	W	Dynamic C	Static C ₀		
UK X05 +H2305	20	62	35	25	26	19	5.1	8	38	2000	1020	0.37	
UK X06 +H2306	25	72	38	30	27	20	5.8	8	45	2640	1400	0.54	
UK X07 +H2307	30	80	43	35	29	21	6.2	9	52	2990	1600	0.70	
UK X08 +H2308	35	85	46	40	30	22	6.5	10	58	3350	1810	0.81	
UK X09 +H2309	40	90	50	45	31	23	6.5	11	65	3600	2010	0.94	
UK X10 +H2310	45	100	55	50	33	24	7.3	12	70	4400	2550	1.22	
UK X11 +H2311	50	110	59	55	36	26	7.7	12	75	5350	3150	1.54	
UK X12 +H2312	55	120	62	60	38	27	8.3	13	80	5850	3500	1.89	
UK X13 +H2313	60	125	65	65	40	29	8.7	14	85	6350	3800	2.09	
UK X15 +H2315	65	140	73	75	44	32	9.6	15	98	7400	4550	3.25	
UK X16 +H2316	70	150	78	80	46	34	10.5	17	105	8500	5500	3.86	
UK X17 +H2317	75	160	82	85	49	36	11.1	18	110	9750	6300	4.72	
UK X18 +H2318	80	170	86	90	52	38	11.9	18	120	11100	7100	5.11	
UK X20 +H2320	90	190	97	100	58	42	13	20	130	13700	9100	8.10	

《Inch series》

Bearing No.	Dimensions in.										Basic Load Rating lb.		Weight lb.
	d ₁	D	L	d	B _i	B _e	T	Y	W	Dynamic C	Static C ₀		
UK X05 +HE 2305 X05 +HA 2305	3/4 5/8	2.4409	1.378	0.9843	1.024	0.748	0.201	0.315	1.496	4410	2250	0.82	
UK X06 +HS 2306 X06 +HA 2306 X06 +HE 2306	7/8 1	2.8346	1.496	1.1811	1.063	0.787	0.228	0.315	1.772	5820	3090	1.19	
UK X07 +HS 2307 X07 +HA 2307	1 1/8 1 1/8	3.1496	1.693	1.3780	1.142	0.827	0.244	0.354	2.047	6590	3530	1.54	
UK X08 +HE 2308 X08 +HA 2308 X08 +HS 2308	1 1/4 1 5/8 1 3/8	3.3465	1.811	1.5748	1.181	0.866	0.256	0.394	2.283	7390	3990	1.79	
UK X09 +HA 2309 X09 +HE 2309 X09 +HS 2309	1 3/4 1 1/2 1 5/8	3.5433	1.969	1.7717	1.220	0.906	0.256	0.433	2.559	7940	4430	2.07	
UK X10 +HA 2310 X10 +HE 2310	1 7/8 1 3/4	3.9370	2.165	1.9685	1.299	0.945	0.287	0.472	2.756	9700	5620	2.69	
UK X11 +HS 2311 X11 +HA 2311 X11 +HE 2311	1 7/8 1 5/8 2	4.3307	2.323	2.1654	1.417	1.024	0.303	0.472	2.953	11800	6940	3.39	
UK X12 +HA 2312 X12 +HS 2312	2 1/8 2 1/8	4.7244	2.441	2.3622	1.496	1.063	0.327	0.512	3.150	12900	7720	4.17	
UK X13 +HA 2313 X13 +HE 2313 X13 +HS 2313	2 3/8 2 1/4 2 5/8	4.9213	2.559	2.5591	1.575	1.142	0.343	0.551	3.346	14000	8380	4.61	
UK X15 +HE 2315	2 1/2	5.5118	2.874	2.9528	1.732	1.260	0.378	0.591	3.858	16300	10000	7.16	
UK X16 +HE 2316	2 3/4	5.9055	3.071	3.1496	1.811	1.339	0.413	0.699	4.134	18700	12100	8.51	
UK X17 +HE 2317	3	6.2992	3.228	3.3465	1.929	1.417	0.437	0.709	4.331	21500	13900	10.40	
UK X18 +HS 2318	3 1/8	6.6929	3.386	3.5433	2.047	1.496	0.469	0.709	4.724	24500	15700	11.26	
UK X20 +HE 2320	3 1/2	7.4803	3.819	3.9370	2.283	1.654	0.512	0.787	5.118	30200	20100	17.85	

BALL BEARINGS

UK 300 +H type

Heavy Duty
Adapter Sleeve Locking

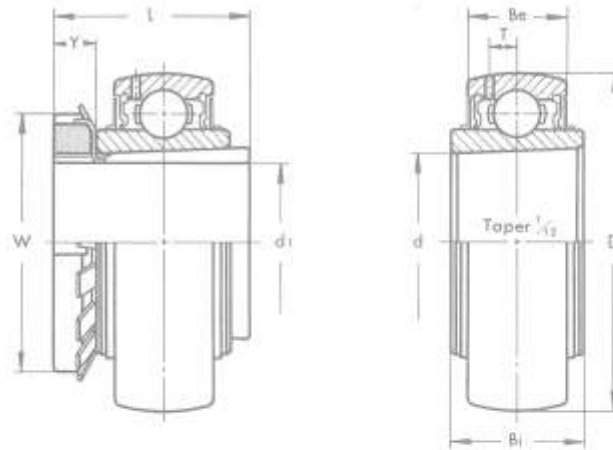

《Metric series》

Bearing No.	Dimensions mm									Basic Load Rating kg		Weight kg
	d ₁	D	L	d	Bi	Be	T	Y	W	Dynamic C	Static C ₀	
UK 305 +H 2305	20	62	35	25	26	21	6.1	8	38	2170	1090	0.48
UK 306 +H 2306	25	72	38	30	29	23	6.7	8	45	2730	1420	0.59
UK 307 +H 2307	30	80	43	35	31	25	7.4	9	52	3400	1820	0.74
UK 308 +H 2308	35	90	46	40	34	27	8.2	10	58	4150	2270	1.01
UK 309 +H 2309	40	100	50	45	37	30	9	11	65	5250	3050	1.31
UK 310 +H 2310	45	110	55	50	40	32	10	12	70	6300	3650	1.68
UK 311 +H 2311	50	120	59	55	43	34	10.7	12	75	7300	4250	2.06
UK 312 +H 2312	55	130	62	60	46	36	11.5	13	80	8300	4900	2.53
UK 313 +H 2313	60	140	65	65	48	38	12.2	14	85	9450	5650	3.07
UK 315 +H 2315	65	160	73	75	54	42	13.8	15	98	11600	7200	4.74
UK 316 +H 2316	70	170	78	80	57	44	14.5	17	105	12500	8150	5.62
UK 317 +H 2317	75	180	82	85	60	46	15	18	110	13500	9100	6.56
UK 318 +H 2318	80	190	86	90	63	48	15.9	18	120	14600	10100	7.32
UK 319 +H 2319	85	200	90	95	66	50	16.7	19	125	15600	11100	8.72
UK 320 +H 2320	90	215	97	100	72	54	18	20	130	17700	13300	10.80
UK 322 +H 2322	100	240	105	110	80	60	21	21	145	20900	17000	14.40
UK 324 +H 2324	110	260	112	120	86	64	22	22	155	21100	17000	18.00
UK 326 +H 2326	115	280	121	130	92	68	23	23	165	23400	19600	23.30
UK 328 +H 2328	125	300	131	140	98	73	25	24	180	26000	22400	28.80

《Inch series》

Bearing No.	Dimensions in.									Basic Load Rating lb.		Weight lb.
	d ₁	D	L	d	Bi	Be	T	Y	W	Dynamic C	Static C ₀	
UK 305 +HE 2305	3/4	2.4409	1.378	0.9843	1.024	0.827	0.240	0.315	1.496	4780	2400	1.06
UK 306 +HE 2306	1	2.8346	1.496	1.1811	1.142	0.906	0.264	0.315	1.772	6020	3130	1.30
UK 307 +HS 2307	1 1/8	3.1496	1.693	1.3780	1.220	0.984	0.291	0.354	2.047	7500	4010	1.63
UK 308 +HE 2308 308 +HS 2308	1 1/4	3.5433	1.811	1.5748	1.339	1.063	0.323	0.394	2.283	9150	5000	2.23
UK 309 +HE 2309 309 +HS 2309	1 1/2	3.9370	1.969	1.7717	1.457	1.181	0.354	0.433	2.559	11570	6720	2.89
UK 310 +HE 2310	1 3/4	4.3307	2.165	1.9685	1.575	1.260	0.394	0.472	2.756	13900	8050	3.70
UK 311 +HS 2311 311 +HE 2311	1 7/8	4.7244	2.323	2.1654	1.693	1.339	0.421	0.472	2.953	16100	9370	4.54
UK 312 +HS 2312	2 1/8	5.1181	2.441	2.3622	1.811	1.417	0.453	0.512	3.150	18300	10600	5.58
UK 313 +HE 2313 313 +HS 2313	2 1/4	5.5118	2.559	2.5591	1.890	1.496	0.480	0.551	3.346	20800	12500	6.77
UK 315 +HE 2315	2 1/2	6.2992	2.874	2.9528	2.126	1.654	0.543	0.591	3.858	25600	15900	10.45
UK 316 +HE 2316	2 3/4	6.6929	3.071	3.1496	2.244	1.732	0.571	0.669	4.134	27600	18000	12.39
UK 317 +HE 2317	3	7.0866	3.228	3.3465	2.362	1.811	0.591	0.709	4.331	29800	20100	14.46
UK 318 +HS 2318	3 1/8	7.4803	3.386	3.5433	2.480	1.890	0.626	0.709	4.724	32200	22300	16.57
UK 319 +HE 2319	3 1/4	7.8740	3.543	3.7402	2.598	1.969	0.657	0.748	4.921	34400	24500	19.22
UK 320 +HE 2320	3 1/2	8.4646	3.819	3.9370	2.835	2.126	0.709	0.787	5.118	39000	29300	23.80
UK 322 +HE 2322	4	9.4488	4.134	4.3307	3.150	2.362	0.827	0.827	5.709	46100	37500	31.74

BALL BEARINGS

UD 200+EE type

Normal Duty
Eccentric Collar Locking

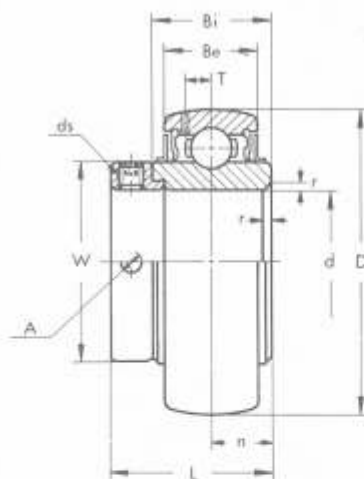

⟨Metric series⟩

Bearing No.	Dimensions mm											Basic Load Rating kg		Weight kg
	d	D	L	B_i	B_e	r	n	T	W	A	d_s	Dynamic C	Static C_0	
UD 204 +EE	20	47	31	23	17	1.5	11.5	4.5	29	4.8	M 5×0.8	1310	630	0.16
UD 205 +EE	25	52	32	23	17	1.5	11.5	4.5	34	4.8	M 6×0.75	1430	710	0.18
UD 206 +EE	30	62	36	26	19	1.5	13	5.1	40	4.8	M 6×0.75	2000	1020	0.30
UD 207 +EE	35	72	38	27	20	2	13.5	5.8	48	4.8	M 8×1	2640	1400	0.44
UD 208 +EE	40	80	40	29	21	2	14.5	6.2	53	4.8	M 8×1	2990	1600	0.56
UD 209 +EE	45	85	42	30	22	2	15	6.5	57	4.8	M 8×1	3350	1810	0.61
UD 210 +EE	50	90	43	31	23	2	15.5	6.5	63	4.8	M 8×1	3600	2010	0.70

* ⟨Inch series⟩

Bearing No.	Dimensions in.											Basic Load Rating lb.		Weight lb.
	d	D	L	B_i	B_e	r	n	T	W	A	d_s (UNF)	Dynamic C	Static C_0	
UD 204-12 +EE	$\frac{3}{4}$	1.8504	1.220	0.906	0.669	0.059	0.453	0.177	1.142	0.189	10-32	2890	1390	0.35
UD 205-14 +EE	$\frac{7}{8}$	2.0472	1.260	0.906	0.669	0.059	0.453	0.177	1.339	0.189	$\frac{1}{4}$ -28	3150	1560	0.40
UD 206-18 +EE	$1\frac{1}{8}$	2.4409	1.417	1.024	0.748	0.059	0.512	0.201	1.575	0.189	$\frac{1}{4}$ -28	4410	2250	0.66
UD 207-20 +EE	$1\frac{1}{4}$	2.8346	1.496	1.063	0.787	0.079	0.531	0.228	1.890	0.189	$\frac{3}{8}$ -24	5820	3090	0.97
UD 207-22 +EE	$1\frac{3}{8}$	2.8346	1.496	1.063	0.787	0.079	0.531	0.228	1.890	0.189	$\frac{3}{8}$ -24	5820	3090	0.97
UD 208-24 +EE	$1\frac{1}{2}$	3.1496	1.575	1.142	0.827	0.079	0.571	0.244	2.087	0.189	$\frac{5}{8}$ -24	6590	3530	1.23
UD 209-26 +EE	$1\frac{5}{8}$	3.3465	1.654	1.181	0.866	0.079	0.591	0.256	2.244	0.189	$\frac{5}{8}$ -24	7390	3990	1.34
UD 209-28 +EE	$1\frac{3}{4}$	3.3465	1.654	1.181	0.866	0.079	0.591	0.256	2.244	0.189	$\frac{5}{8}$ -24	7390	3990	1.34
UD 210-30 +EE	$1\frac{7}{8}$	3.5433	1.693	1.220	0.906	0.079	0.610	0.256	2.480	0.189	$\frac{5}{8}$ -24	7940	4430	1.54

BALL BEARINGS

B type

Light Duty
Set-screw Locking

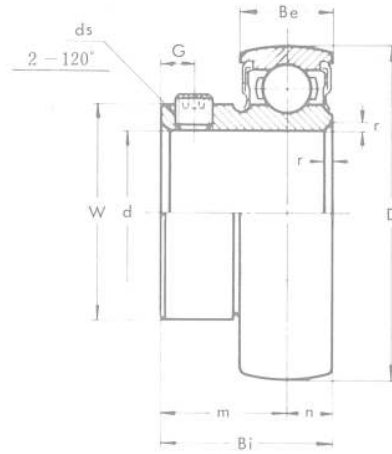

《Metric series》

Bearing No.	Dimensions mm										Basic Load Rating kg		Weight kg
	d	D	Bi	Be	r	n	m	G	ds	W	Dynamic C	Static Co	
B 1	12	40	22	12	1	6	16	4	M5×0.8	24.7	975	455	0.10
B 2	15	40	22	12	1	6	16	4	M5×0.8	24.7	975	455	0.09
B 3	17	40	22	12	1	6	16	4	M5×0.8	24.7	975	455	0.07
B 4	20	47	24.7	14	1.5	7	17.7	4.5	M5×0.8	29	1310	630	0.12
B 5	25	52	27	15	1.5	7.5	19.5	5	M6×0.75	34	1430	710	0.16
B 6	30	62	30.3	16	1.5	8	22.3	5	M6×0.75	40.5	2000	1020	0.25
B 7	35	72	32.9	17	2	8.5	24.4	6	M8×1	48	2640	1400	0.38

《Inch series》

Bearing No.	Dimensions in.										Basic Load Rating lb.		Weight lb.
	d	D	Bi	Be	r	n	m	G	ds(UNF)	W	Dynamic C	Static Co	
B 1-8	1/2	1.5748	0.866	0.472	0.039	0.236	0.630	0.157	10-32	0.972	2150	1000	0.22
* B 2-9	9/16												0.20
2-10	5/8												0.15
* B 3-11	11/16	1.8504	0.972	0.551	0.059	0.276	0.697	0.177	10-32	1.142	2890	1390	0.26
B 4-12	3/4												0.26
B 5-14	7/8												0.35
* B 5-15	15/16	2.0472	1.063	0.591	0.059	0.295	0.767	0.197	1/4-28	1.339	3150	1560	0.35
B 5-16	1												0.35
B 6-18	1 1/8												2.4409
B 6-19	1 3/16	0.55											
B 7-20	1 1/4	2.8346	1.295	0.669	0.079	0.335	0.961	0.236	5/16-24	1.890	5820	3090	
* B 7-21	1 5/16												0.84
B 7-22	1 3/8												0.84
B 7-23	1 7/16												0.84

BALL BEARINGS WITH SNAP RING

* SER 200 type

Normal Duty
Set-screw Locking

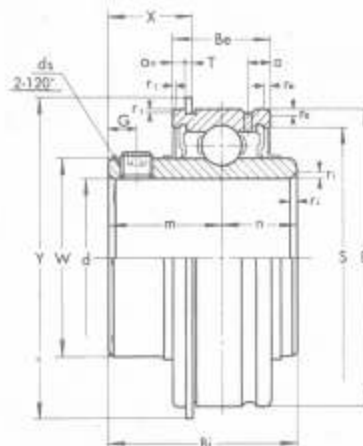

<Metric series>

Bearing No.	Dimensions mm																	Basic Load Rating kg		Weight kg	
	d	D	Bi	Be	ri	re	r ₁ (Min.)	n	m	G	ds	o	W	an	T	Y (Max.)	X	S	Dynamic C		Static C _s
SER 201	12	47	31	15.9	1	1.5	0.5	10.3	20.7	4.5	M 6×0.75	3.8	29	2.38	1.07	52.7	16.15	41	1310	630	0.27
SER 202	15	47	31	15.9	1	1.5	0.5	10.3	20.7	4.5	M 6×0.75	3.8	29	2.38	1.07	52.7	16.15	41	1310	630	0.25
SER 203	17	47	31	15.9	1	1.5	0.5	10.3	20.7	4.5	M 6×0.75	3.8	29	2.38	1.07	52.7	16.15	41	1310	630	0.23
SER 204	20	47	31	15.9	1.5	1.5	0.5	10.3	20.7	4.5	M 6×0.75	3.8	29	2.38	1.07	52.7	16.15	41	1310	630	0.22
SER 205	25	52	34.9	19	1.5	1.5	0.5	13.1	21.8	5	M 6×0.75	5.2	34	2.38	1.07	57.9	15.75	46	1430	710	0.28
SER 206	30	62	38.1	22.2	1.5	1.5	0.5	15.9	22.2	5	M 6×0.75	5.6	40.5	3.18	1.65	67.7	15.93	54.3	2000	1020	0.38
SER 207	35	72	42.9	23.8	2	2	0.5	17.5	25.4	6	M 8×1.0	5.6	48	3.18	1.65	78.6	18.32	63.5	2640	1400	0.56
SER 208	40	80	49.2	27.8	2	2	0.5	19	30.2	8	M 8×1.0	6.4	53	3.18	1.65	86.6	21.1	69.3	2990	1600	0.87
SER 209	45	85	49.2	27.8	2	2	0.5	19	30.2	8	M 8×1.0	6.4	57.3	3.18	1.65	91.6	21.1	74.3	3350	1810	0.95
SER 210	50	90	51.6	28.6	2	2	0.5	19	32.6	9	M10×1.25	7.5	63	3.18	2.41	96.5	23.84	79.7	3600	2010	1.03
SER 211	55	100	55.6	30.2	2.5	2.5	0.5	22.2	33.4	9	M10×1.25	7.5	70	3.18	2.41	106.5	23.84	90.7	4400	2550	1.21
SER 212	60	110	65.1	31.8	2.5	2.5	0.5	25.4	39.7	10	M10×1.25	7.5	77	3.18	2.41	116.6	29.4	100	5350	3150	1.68

<Inch series>

Bearing No.	Dimensions in.																	Basic Load Rating lb.		Weight lb.	
	d	D	Bi	Be	ri	re	r ₁ (Min.)	n	m	G	ds(UNF)	o	W	an	T	Y (Max.)	X	S	Dynamic C		Static C _s
SER 201-8	1/2																				0.60
SER 202-9	5/8	1.8504	1 1/8	5/8	0.039	0.059	0.020	1/2	1 1/8	0.177	1/4-28	0.150	1.142	3/8	0.042	2.075	0.636	1.614	2890	1390	0.55
SER 202-10	5/8																				0.51
SER 203-11	3/4	1.8504	1 1/8	5/8	0.059	0.059	0.020	1/2	1 1/8	0.177	1/4-28	0.150	1.142	3/8	0.042	2.075	0.636	1.614	2890	1390	0.48
SER 204-12	3/4																				0.48
SER 205-14	7/8	2.0472	1 3/8	3/4	0.059	0.059	0.020	5/8	1 3/8	0.197	1/4-28	1/8	1.339	3/8	0.042	2.280	0.620	1.811	3150	1560	0.62
SER 205-15	7/8																				0.62
SER 205-16	1																				0.62
SER 206-17	1 1/8	2.4409	1 1/2	7/8	0.059	0.059	0.020	5/8	1 3/8	0.197	1/4-28	3/8	1.594	1/2	0.065	2.665	0.628	2.138	4410	2250	0.84
SER 206-18	1 1/8																				0.84
SER 206-19	1 1/8																				0.84
SER 207-20	1 1/4	2.8346	1 5/8	7/8	0.079	0.079	0.020	1/2	1	0.236	5/8-24	3/8	1.890	1/2	0.065	3.095	0.721	2.500	5820	3090	1.23
SER 207-21	1 1/4																				1.23
SER 207-22	1 1/4																				1.23
SER 207-23	1 1/4																				1.23
SER 208-24	1 1/2	3.1498	1 3/4	1 1/8	0.079	0.079	0.020	3/4	1 3/4	0.315	5/8-24	1/2	2.087	1/2	0.065	3.410	0.831	2.728	6590	3530	1.92
SER 208-25	1 1/2																				1.92
SER 209-26	1 5/8	3.3465	1 3/4	1 1/8	0.079	0.079	0.020	3/4	1 3/4	0.315	5/8-24	1/2	2.256	1/2	0.065	3.606	0.831	2.925	7390	3990	2.09
SER 209-27	1 5/8																				2.09
SER 209-28	1 5/8																				2.09
SER 210-30	1 3/4	3.5433	2 1/8	1 1/8	0.079	0.079	0.020	3/4	1 3/4	0.354	3/8-24	3/4	2.480	1/2	0.095	3.799	0.939	3.138	7940	4430	2.27
SER 210-31	1 3/4																				2.27
SER 211-32	2	3.9370	2 3/8	1 3/4	0.098	0.098	0.020	7/8	1 3/4	0.354	3/8-24	3/4	2.756	1/2	0.095	4.193	0.939	3.571	9700	5620	2.67
SER 211-34	2																				2.67
SER 211-35	2 3/8																				2.67
SER 212-36	2 1/4	4.3307	2 5/8	1 1/4	0.098	0.098	0.020	1	1 3/4	0.394	3/8-24	3/4	3.031	1/2	0.095	4.591	1.158	3.937	11800	6940	3.70
SER 212-38	2 1/4																				3.70
SER 212-39	2 1/4																				3.70

BALL BEARINGS

UG 200+ER type

Normal Duty
Eccentric Collar Locking

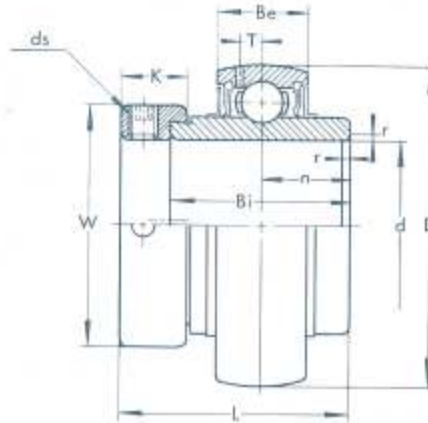

《Metric series》

Bearing No.	Dimensions (mm)											Basic Load Rating (kgf)		Weight (kg)
	d	D	L	Bi	Be	r	n	T	W	K	ds	Dynamic C _r	Static C ₀	
UGW 201+ER	12	40	37.3	27.8	15	1	13.9	4	28.6	13.5	M 6×0.75	975	460	0.16
UGW 202+ER	15	40	37.3	27.8	15	1	13.9	4	28.6	13.5	M 6×0.75	975	460	0.14
UGW 203+ER	17	40	37.3	27.8	15	1	13.9	4	28.6	13.5	M 6×0.75	975	460	0.13
UG 204+ER	20	47	43.7	34.2	17	1.5	17.1	4.5	33.3	13.5	M 6×0.75	1310	635	0.21
UG 205+ER	25	52	44.4	34.9	17	1.5	17.5	4.5	38.1	13.5	M 6×0.75	1430	730	0.23
UG 206+ER	30	62	48.4	36.5	19	1.5	18.3	5.1	44.5	15.9	M 8×1	2000	1050	0.37
UG 207+ER	35	72	51.1	37.6	20	2	18.8	5.8	55.6	17.5	M10×1.25	2640	1430	0.6
UG 208+ER	40	80	56.3	42.8	21	2	21.4	6.2	60.3	18.3	M10×1.25	2990	1650	0.76
UG 209+ER	45	85	56.3	42.8	22	2	21.4	6.5	63.5	18.3	M10×1.25	3350	1890	0.79
UG 210+ER	50	90	62.7	49.2	23	2	24.6	6.5	69.9	18.3	M10×1.25	3600	2110	0.91
UG 211+ER	55	100	71.4	55.5	24	2.5	27.8	7.3	76.2	20.7	M12×1.5	4400	2670	1.26
UG 212+ER	60	110	77.8	61.9	26	2.5	31	7.7	84.2	22.3	M12×1.5	5350	3300	1.7

《Inch series》

Bearing No.	Dimensions (in)											Basic Load Rating (lbf)		Weight (lb)
	d	D	L	Bi	Be	r	n	T	W	K	ds (UNF)	Dynamic C _r	Static C ₀	
UGW 201-B+ER	1/2	1.5748	1 1/8	1 3/8	0.591	0.039	3/4	0.157	1 1/8	5/8	1/4-28	2150	1010	0.35
UGW 202-9+ER	5/8													
UGW 202-10+ER	5/8													
UGW 203-11+ER	3/4	1.8504	1 3/8	1 1/2	0.669	0.059	3/4	0.177	1 1/2	5/8	1/4-28	2890	1400	0.46
UG 204-12+ER	3/4													
UG 205-14+ER	7/8													
UG 205-15+ER	7/8	2.0472	1 3/4	1 3/8	0.669	0.059	3/4	0.177	1 1/2	5/8	1/4-28	3150	1610	0.51
UG 205-16+ER	1													
UG 206-18+ER	1 1/8													
UG 206-19+ER	1 1/8	2.4409	1 3/4	1 7/8	0.748	0.059	3/4	0.201	1 3/4	5/8	5/8-24	4410	2310	0.82
UG 206-20+ER	1 1/4													
UG 207-20+ER	1 1/4													
UG 207-21+ER	1 1/4	2.8346	2 1/4	1 3/4	0.787	0.079	3/4	0.228	2 3/8	5/8	3/8-24	5820	3150	1.32
UG 207-22+ER	1 3/8													
UG 207-23+ER	1 3/8													
UG 208-24+ER	1 1/2													
UG 208-25+ER	1 3/4	3.1496	2 3/8	1 3/4	0.827	0.079	3/4	0.244	2 3/8	5/8	3/8-24	6590	3640	1.68
UG 209-26+ER	1 3/8													
UG 209-27+ER	1 3/8													
UG 209-28+ER	1 3/4	3.3465	2 3/8	1 3/4	0.866	0.079	3/4	0.256	2 1/2	5/8	3/8-24	7390	4170	1.74
UG 210-30+ER	1 3/8													
UG 210-31+ER	1 3/8													
UG 211-32+ER	2	3.9370	2 3/4	2 3/8	0.945	0.098	1 3/8	0.287	3	5/8	3/8-20	9700	5880	2.78
UG 211-34+ER	2 1/8													
UG 211-35+ER	2 3/8													
UG 212-36+ER	2 1/4	4.3307	3 1/4	2 3/4	1.024	0.098	1 3/8	0.303	3 3/8	7/8	3/8-20	11800	7270	3.75
UG 212-38+ER	2 3/8													
UG 212-39+ER	2 3/4													

Note: UG 200+ER series has superseded FG 200+ER bearings.
For availability of the former FG 200+ER, please check with us.

BALL BEARINGS

KH 200 AE type
KHR 200 AE type

Light Duty
Eccentric Collar Locking

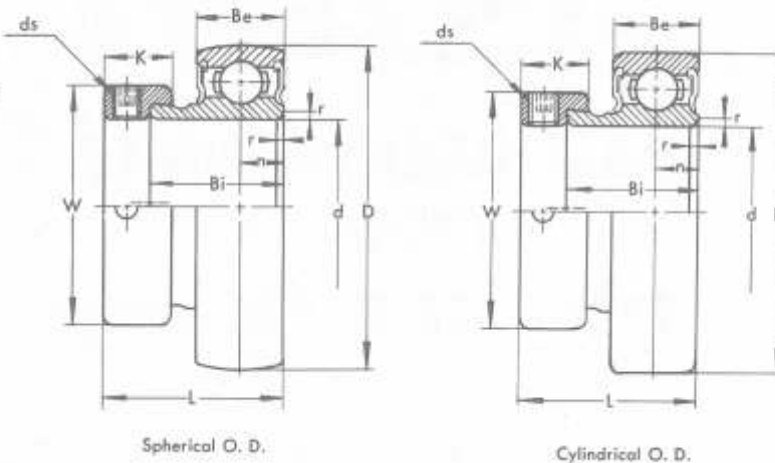

《Metric series》

Bearing No.		Dimensions (mm)											Basic Load Rating (kgf)		Weight (kg)
Spherical O.D.	Cylindrical O.D.	d	D	L	Bi	Be	r	T	n	W	K	ds	Dynamic C	Static C ₀	
KH 201 AE	KHR 201 AE	12	40	28.6	19.1	12	1	3.6	6.5	28.6	13.5	M 6×0.75	975	460	0.12
KH 202 AE	KHR 202 AE	15	40	28.6	19.1	12	1	3.6	6.5	28.6	13.5	M 6×0.75	975	460	0.11
KH 203 AE	KHR 203 AE	17	40	28.6	19.1	12	1	3.6	6.5	28.6	13.5	M 6×0.75	975	460	0.1
KH 204 AE	KHR 204 AE	20	47	31	21.5	14	1.5	4.1	7.5	33.3	13.5	M 6×0.75	1310	635	0.16
KH 205 AE	KHR 205 AE	25	52	31	21.5	15	1.5	4.1	7.5	38.1	13.5	M 6×0.75	1430	730	0.2
KH 206 AE	KHR 206 AE	30	62	35.7	23.8	16	1.5	4.9	9	44.5	15.9	M 8×1	2000	1050	0.31
KH 207 AE	KHR 207 AE	35	72	38.9	25.4	17	2	5.4	9.5	55.6	17.5	M10×1.25	2640	1430	0.49
KH 208 AE	KHR 208 AE	40	80	43.7	30.2	18	2	5.9	11	60.3	18.3	M10×1.25	2990	1650	0.62
KH 209 BE	KHR 209 BE	45	85	43.7	30.2	19	2	6.2	11	63.5	18.3	M10×1.25	3350	1890	0.65
KH 210 BE	KHR 210 BE	50	90	43.7	30.2	20	2	6.5	11	69.9	18.3	M10×1.25	3600	2110	0.75
KH 211 BE	KHR 211 BE	55	100	48.4	32.5	21	2.5	7	12	76.2	20.7	M12×1.5	4400	2670	0.94

《Inch series》

Bearing No.		Dimensions (in)											Basic Load Rating (lbf)		Weight (lb)
Spherical O.D.	Cylindrical O.D.	d	D	L	Bi	Be	r	T	n	W	K	ds (UNF)	Dynamic C	Static C ₀	
KH 201-8AE	KHR 201-8AE	1/2	1.5748	1 1/8	0.752	0.472	0.039	0.142	0.256	1 1/8	3/8	3/8-28	2150	1010	0.26
KH 202-9AE	KHR 202-9AE	3/8													
KH 202-10AE	KHR 202-10AE	7/16													
KH 203-11AE	KHR 203-11AE	3/4	1.8504	1 7/16	0.846	0.551	0.059	0.161	0.295	1 1/8	3/8	3/8-28	2890	1400	0.22
KH 204-12AE	KHR 204-12AE	3/4													
KH 205-14AE	KHR 205-14AE	7/8													
KH 205-15AE	KHR 205-15AE	15/16	2.0472	1 7/16	0.846	0.591	0.059	0.161	0.295	1 1/8	3/8	3/8-28	3150	1610	0.35
KH 205-16AE	KHR 205-16AE	1													
KH 206-18AE	KHR 206-18AE	1 1/8													
KH 206-19AE	KHR 206-19AE	1 1/4	2.4409	1 1/2	0.938	0.630	0.059	0.193	0.354	1 3/4	5/8	5/8-24	4410	2310	0.44
KH 206-20AE	KHR 206-20AE	1 1/2													
KH 207-20AE	KHR 207-20AE	1 1/4													
KH 207-21AE	KHR 207-21AE	1 3/8	2.8346	1 1/2	1.000	0.669	0.079	0.213	0.374	2 3/8	3/4	3/8-24	5820	3150	0.68
KH 207-22AE	KHR 207-22AE	1 3/8													
KH 207-23AE	KHR 207-23AE	1 3/8													
KH 208-24AE	KHR 208-24AE	1 1/2	3.1496	1 3/8	1.188	0.709	0.079	0.232	0.433	2 3/8	3/8	3/8-24	6590	3640	1.08
KH 208-25AE	KHR 208-25AE	1 3/4													
KH 209-26BE	KHR 209-26BE	1 5/8													
KH 209-27BE	KHR 209-27BE	1 3/4	3.3465	1 3/8	1.188	0.748	0.079	0.244	0.433	2 1/2	3/8	3/8-24	7390	4170	1.37
KH 209-28BE	KHR 209-28BE	1 3/4													
KH 210-30BE	KHR 210-30BE	1 7/8													
KH 210-31BE	KHR 210-31BE	1 3/4	3.5433	1 3/8	1.188	0.787	0.079	0.256	0.433	2 3/8	3/8	3/8-24	7940	4650	1.43
KH 211-32BE	KHR 211-32BE	2													
KH 211-34BE	KHR 211-34BE	2 1/8													
KH 211-35BE	KHR 211-35BE	2 3/8	3.9370	1 3/2	1.281	0.827	0.098	0.276	0.472	3	3/4	3/4-20	9700	5880	1.65
KH 211-32BE	KHR 211-32BE	2													
KH 211-34BE	KHR 211-34BE	2 1/8													

ASAHI

BALL BEARING UNITS SILVER series

STAINLESS SILVER series

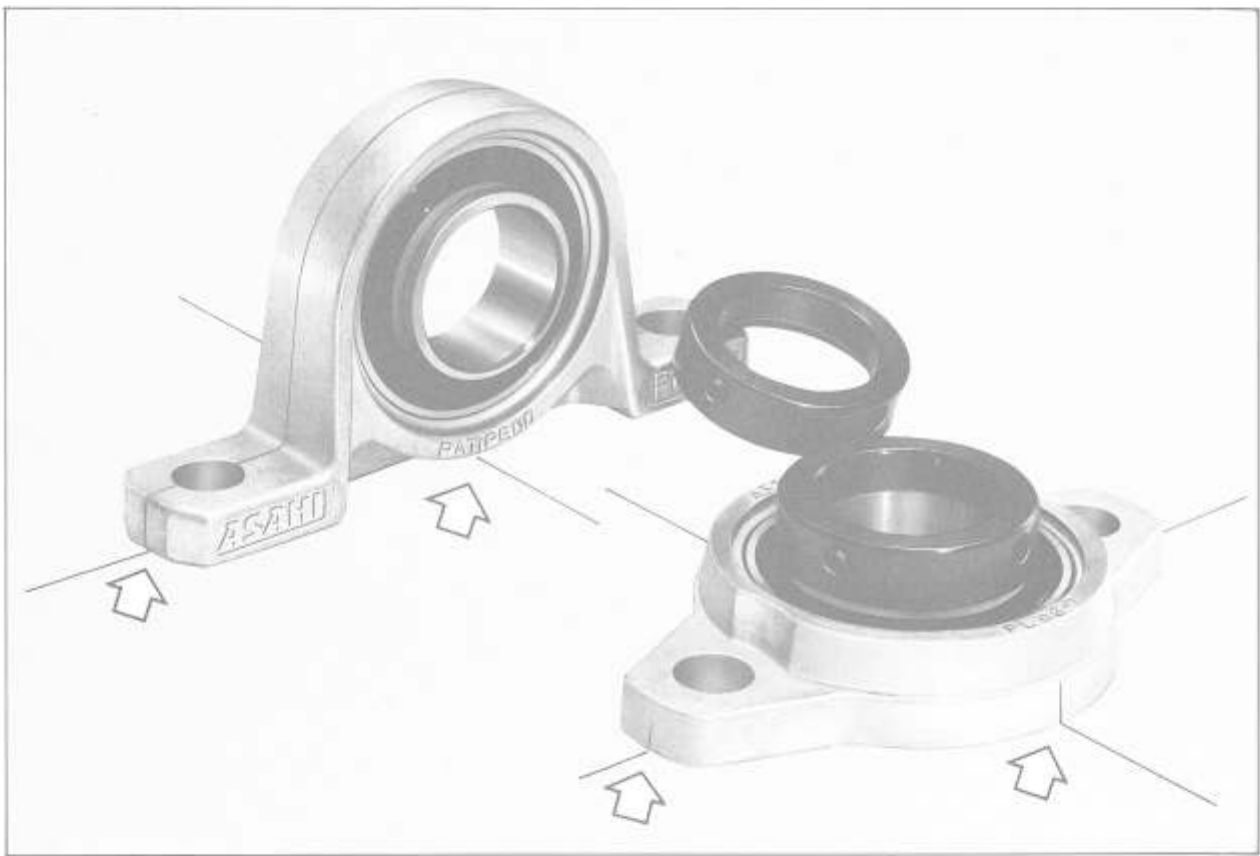

● QUICK, ACCURATE POSITIONING BY CENTER-LINE MARKS

Center-line marks provided on housing offer easy, quick and exact positioning, eliminating need for adjustment after mounting. For positioning, just scribe the lines on supporting frame and match them with the center-line marks.

● COMPACT & LIGHT-WEIGHTED

This feature permits high performance and more space-saving machine and equipment designs.

● EASY & QUICK TO MOUNT

Eccentric locking collar ensures fast and positive locking of bearing to the shaft.

● HIGH SEALING EFFICIENCY

Bearings are effectively sealed. For added protection against dust and humid, units fitted with stainless steel end covers are also available.

● HIGH ANTI-CORROSIVENESS (STAINLESS SILVER series)

Suitable for applications under adverse environmental conditions.

● HIGH SPEED OPERATION

Compact bearing design permits high speed operation.

Pillow blocks

UP000 type

UP000C(E) type

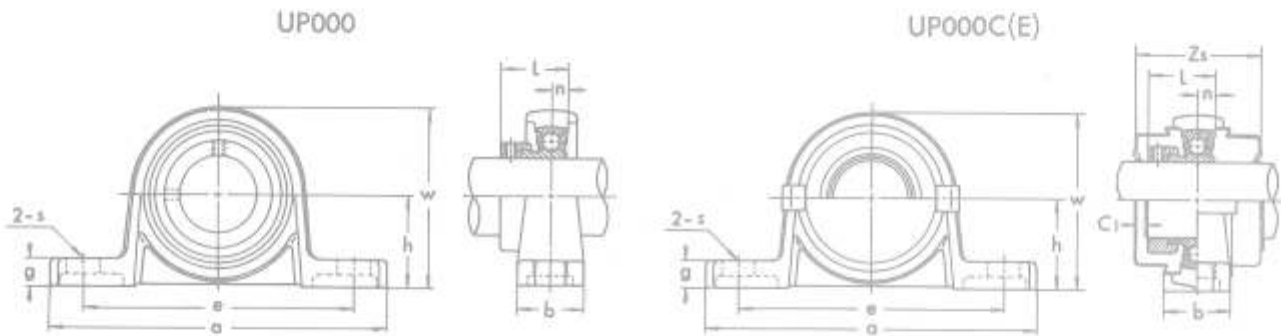

Shaft dia. (mm)	Unit No.	Dimensions (mm)											Mounting bolt size
		h	a	e	b	s	g	w	L	n	C1	Zs	
8	※ UP08	15	55	42	13	4.8	5	29	15	3.5	—	—	M 4
10	UP000	18	67	53	16	7	6	35	17.5	4	2	33	M 6
12	UP001	19	71	56	16	7	6	38	17.5	4	2	33	M 6
15	UP002	22	80	63	16	7	7	43	18.5	4.5	2	34	M 6
17	UP003	24	85	67	18	7	7	47	20.5	5	2	38	M 6
20	UP004	28	100	80	20	10	9	55	24.5	6	3	46	M 8
25	UP005	32	112	90	20	10	10	62	25.5	6	3	47	M 8
30	UP006	36	132	106	26	13	11	70	26.5	6.5	4	50	M10

Bearing No.	Bearing		Housing No.	Unit No. with covers	Stainless steel cover No.		Weight (g)		
	Basic load rating (kgf) (1 kgf=9.8N)				Open (closed)	Open	Closed	Normal	With cover
	Cr	Cor							
U08 + ER	340	170	※ P08	—	—	—	47	—	
U000 + ER	470	200	P000	UP000C(E)	000CP10	000CPE	77	85	
U001 + ER	520	245	P001	UP001C(E)	001CP12	001CPE	91	100	
U002 + ER	570	290	P002	UP002C(E)	002CP15	002CPE	125	135	
U003 + ER	610	335	P003	UP003C(E)	003CP17	003CPE	156	170	
U004 + ER	955	515	P04-5	UP004C(E)	04-5CP20	04-5CPE	230	250	
U005 + ER	1030	595	P05-6	UP005C(E)	05-6CP25	05-6CPE	294	315	
U006 + ER	1350	845	P06-7	UP006C(E)	06-7CP30	06-7CPE	454	480	

Note: ※ For availability of UP08, please check with us.
Cr: Dynamic load rating, Cor: Static load rating

● Tolerances

In conformity with JIS B 1558 on ball bearings for units and JIS B 1559 on housings for bearing units.

● Operating temperature range

-10°C to +80°C. For operating temperature beyond this range, please consult us.

● Shaft selection

Shaft dia. (mm)		Unit: μm	
Over	Incl.	js7	h7
6	10	± 7.5	0 ~ -15
10	18	± 9	0 ~ -18
18	30	± 10.5	0 ~ -21
30	50	± 12.5	0 ~ -25

Note: Use tight fit for applications involving high speed and vibration.

Two-bolt flange units

UFL000 type

UFL000C(E) type

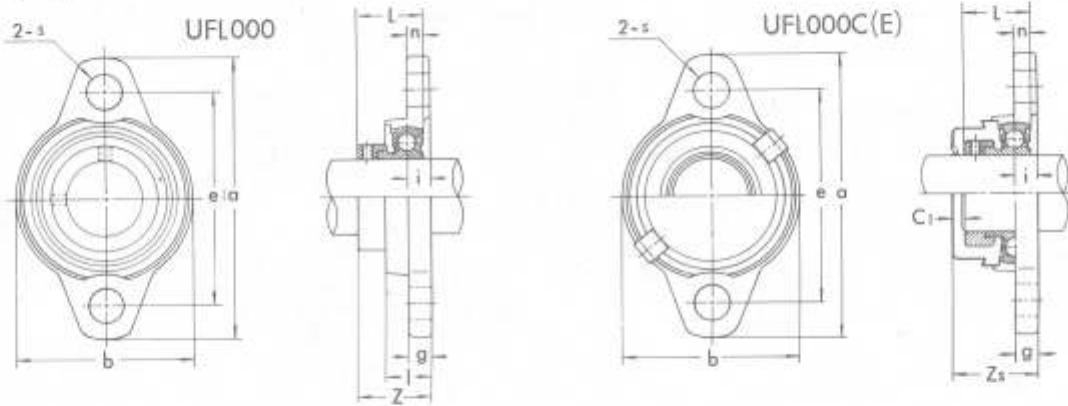

Shaft dia. (mm)	Unit No.	Dimensions (mm)												Mounting bolt size
		a	e	i	g	l	s	b	Z	L	n	C ₁	Z _s	
8	UFL08	48	37	4.5	4	8.5	4.8	27	16	15	3.5	—	—	M 4
10	UFL000	60	45	5.5	5.5	11.5	7	36	19	17.5	4	2	22	M 6
12	UFL001	63	48	5.5	5.5	11.5	7	38	19	17.5	4	2	22	M 6
15	UFL002	67	53	6.5	6.5	13	7	42	20.5	18.5	4.5	2	24	M 6
17	UFL003	71	56	7	7	14	7	46	22.5	20.5	5	2	26	M 6
20	UFL004	90	71	8	8	16	10	55	26.5	24.5	6	3	31	M 8
25	UFL005	95	75	8	8	16	10	60	27.5	25.5	6	3	32	M 8
30	UFL006	112	85	9	9	18	13	70	29	26.5	6.5	4	34	M10
35	UFL007	122	95	10	10	20	13	80	32.5	29.5	7	4	38	M10

Bearing No.	Bearing		Housing No.	Unit No. with covers	Stainless steel cover No.		Weight (g)	
	Basic load rating (kgf) (1 kgf=9.8N)				Open(closed)	Open	Closed	Normal
	C _r	C _{or}						
U08 + ER	340	170	FL08	—	—	—	30	—
U000 + ER	470	200	FL000	UFL000C(E)	000CP10	000CPE	60	65
U001 + ER	520	245	FL001	UFL001C(E)	001CP12	001CPE	76	80
U002 + ER	570	290	FL002	UFL002C(E)	002CP15	002CPE	100	105
U003 + ER	610	335	FL003	UFL003C(E)	003CP17	003CPE	129	135
U004 + ER	955	515	FL04-5	UFL004C(E)	04.5CP20	04.5CPE	205	215
U005 + ER	1030	595	FL05-6	UFL005C(E)	05.6CP25	05.6CPE	244	255
U006 + ER	1350	845	FL06-7	UFL006C(E)	06.7CP30	06.7CPE	354	370
U007 + ER	1625	1050	FL07-8	UFL007C(E)	07.8CP35	07.8CPE	498	520

● Recommended tightening torque of set-screws and axial load capacity

Applicable bearing Nos.	Set-screw No.	Hexagon socket screw key No.	Tightening torque (kgf cm)	Axial load capacity (kgf)
U08	M3×0.5	1.5	6	40
U000~U003, MU000~MU003	M4×0.7	2	15	90
U004~U006, MU004~MU006	M5×0.8	2.5	30	180
U007	M6×0.75	3	50	300

Note: As the operating radial load increases, the axial load carrying capacity also increases.

Pillow blocks

MUP000 type

MUP000C(E) type

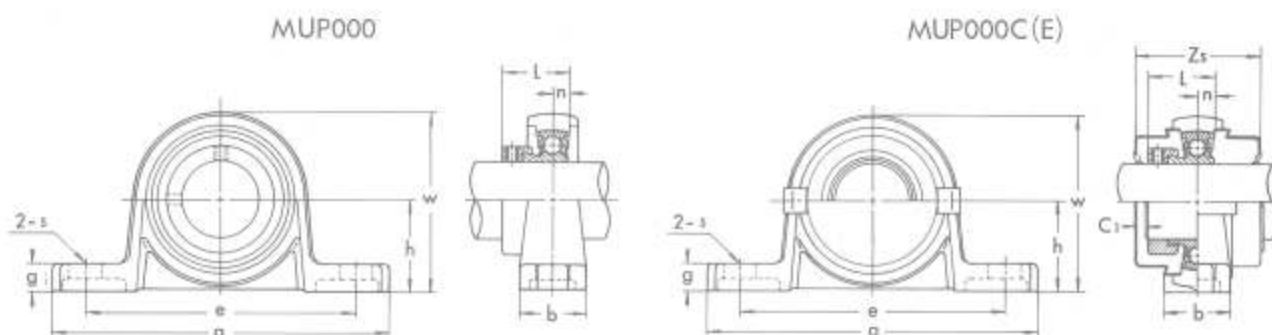

Shaft dia. (mm)	Unit No.	Dimensions (mm)											Mounting bolt size
		h	a	e	b	s	g	w	L	n	C1	Zs	
10	MUP000	18	67	53	16	7	6	35	17.5	4	2	33	M 6
12	MUP001	19	71	56	16	7	6	38	17.5	4	2	33	M 6
15	MUP002	22	80	63	16	7	7	43	18.5	4.5	2	34	M 6
17	MUP003	24	85	67	18	7	7	47	20.5	5	2	38	M 6
20	MUP004	28	100	80	20	10	9	55	24.5	6	3	46	M 8
25	MUP005	32	112	90	20	10	10	62	25.5	6	3	47	M 8
30	MUP006	36	132	106	26	13	11	70	26.5	6.5	4	50	M10

Bearing No.	Bearing		Housing No.	Unit No. with covers	Stainless steel cover No.		Weight (g)	
	Basic load rating (kgf) (1 kgf=9.8N)				Open (closed)	Open	Closed	Normal
	Cr	Cor						
MU000+ER	400	160	P000Z3	MUP000C(E)	000CP10	000CPE	77	85
MU001+ER	440	195	P001Z3	MUP001C(E)	001CP12	001CPE	91	100
MU002+ER	485	230	P002Z3	MUP002C(E)	002CP15	002CPE	125	135
MU003+ER	520	270	P003Z3	MUP003C(E)	003CP17	003CPE	156	170
MU004+ER	810	410	P04-5Z3	MUP004C(E)	04-5CP20	04-5CPE	230	250
MU005+ER	875	475	P05-6Z3	MUP005C(E)	05-6CP25	05-6CPE	294	315
MU006+ER	1150	675	P06-7Z3	MUP006C(E)	06-7CP30	06-7CPE	454	480

●Materials

Series	SILVER	STAINLESS SILVER
Unit No.	UP000, UFL000 UP000C(E), UFL000C(E)	MUP000, MUFL000 MUP000C(E), MUFL000C(E)
Bearing	High carbon chromium bearing steel (SUJ2)	Stainless steel (SUS4400)
Rubber seal	NBR	
Eccentric locking collar	Carbon steel for machine structure (SxxC) or Rolled steel for general structure (SS)	
	Black oxide treatment	Electro plated (MFCr)
Housing	Zinc alloy die-casting (ZDC)	
	—	Electro plated (MZCr)
Stainless steel cover	Stainless steel (SUS430)	

●Limiting speed

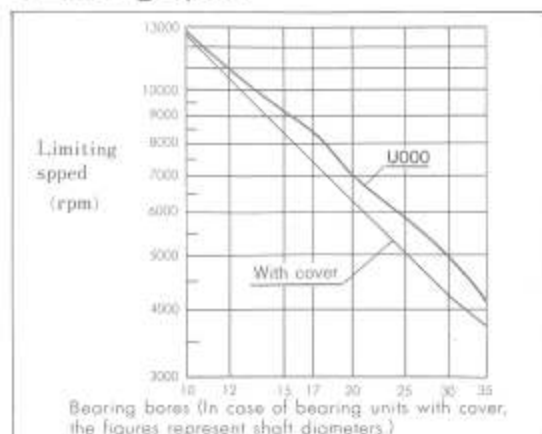

Two-bolt flange units

MUFL000 type

MUFL000C(E) type

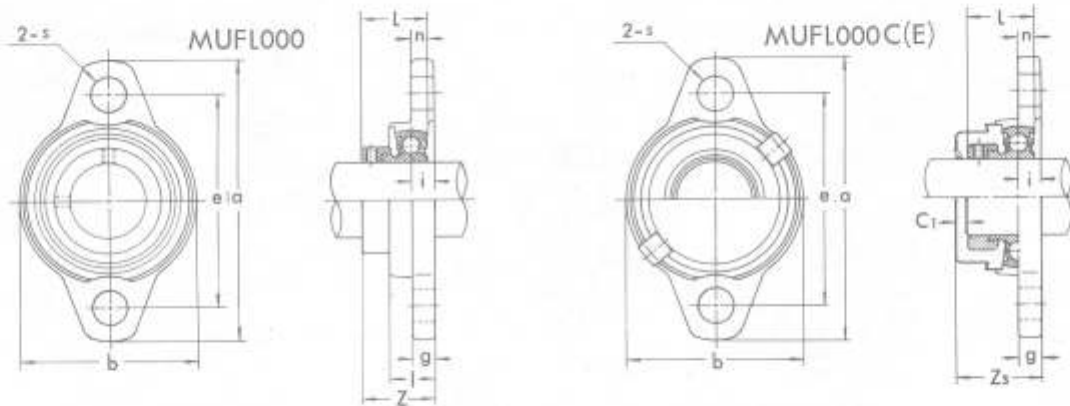

Shaft dia. (mm)	Unit No.	Dimensions (mm)											Mounting bolt size	
		a	e	i	g	l	s	b	Z	L	n	Ct		Zs
10	MUFL000	60	45	5.5	5.5	11.5	7	36	19	17.5	4	2	22	M 6
12	MUFL001	63	48	5.5	5.5	11.5	7	38	19	17.5	4	2	22	M 6
15	MUFL002	67	53	6.5	6.5	13	7	42	20.5	18.5	4.5	2	24	M 6
17	MUFL003	71	56	7	7	14	7	46	22.5	20.5	5	2	26	M 6
20	MUFL004	90	71	8	8	16	10	55	26.5	24.5	6	3	31	M 8
25	MUFL005	95	75	8	8	16	10	60	27.5	25.5	6	3	32	M 8
30	MUFL006	112	85	9	9	18	13	70	29	26.5	6.5	4	34	M10

Bearing No.	Bearing		Housing No.	Unit No. with covers	Stainless steel cover No.		Weight (g)		
	Basic load rating (kgf) (1 kgf=9.8N)				Open(closed)	Open	Closed	Normal	With cover
	Cr	Cor							
MU000+ER	400	160	FL000Z3	MUFL000C(E)	000CP10	000CPE	60	65	
MU001+ER	440	195	FL001Z3	MUFL001C(E)	001CP12	001CPE	76	80	
MU002+ER	485	230	FL002Z3	MUFL002C(E)	002CP15	002CPE	100	105	
MU003+ER	520	270	FL003Z3	MUFL003C(E)	003CP17	003CPE	129	135	
MU004+ER	810	410	FL04-5Z3	MUFL004C(E)	04-5CP20	04-5CPE	205	215	
MU005+ER	875	475	FL05-6Z3	MUFL005C(E)	05-6CP25	05-6CPE	244	255	
MU006+ER	1150	675	FL06-7Z3	MUFL006C(E)	06-7CP30	06-7CPE	354	370	

● Breaking strength of housings

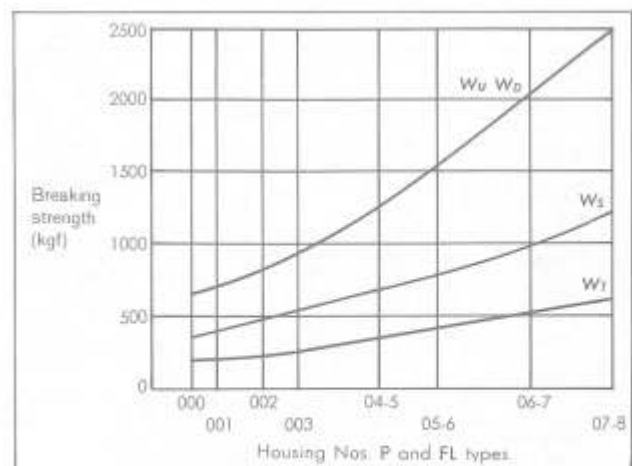
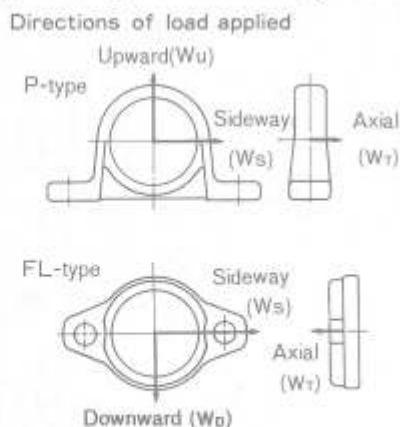

ASAHI

BEARING UNITS

ENGINEERING DATA

IMPORTANT NOTICE

This edition contains revised "Basic Dynamic Load Ratings".

The new basic dynamic load ratings, whose C values are increased by 30% over the values contained in our previous publications, have resulted from the improved life properties of our bearings, and the new values supersede the old ones.

Calculations of dynamic load ratings and rating lives of the bearings are in conformity with the standards established by ISO 281/1-1977 (corresponding JIS 1518-1981), which formulates the adjusted rating life as follows: —

$$L_{na} = a_1 a_2 a_3 L_{10}$$

where:

$$L_{10} = \left(\frac{C}{P} \right)^3$$

L_{na} : Adjusted rating life in millions of revolutions taking into account reliability (100 — n)%, where the index "n" represents the difference between the requisite reliability, bearing materials and operating conditions.

a_1 : Life adjustment factor for reliability

a_2 : Life adjustment factor for materials

a_3 : Life adjustment factor for operating conditions

Please note that the new basic dynamic load ratings have been determined taking into account the fact that the standard bearing steels used for our bearings have better life properties than the materials on which the equation by ISO are based. Therefore, when using these new load ratings, the value for a_2 factor should be $a_2 = 1$. Other values, i.e., a_1 and a_3 factors should be properly used according to the guidances given in the same standard.

Load Rating Data on page 80 — 81 and other related figures and values are based on new basic dynamic load ratings.

1. TOLERANCES FOR BEARING UNITS

1.1 Tolerances for bearings

1) Inner rings

Table 1.1 Tolerances on inner rings of bearings with cylindrical bore

Unit: 0.001 mm
(0.0001 in.)

Nominal bore diameter d				Deviation of mean bore diameter in plane of inner ring		Variation of bore diameter in plane of inner ring	Deviation of inner ring width		Radial runout of inner ring	Eccentricity deviation of eccentric surface of inner ring and eccentric locking collar
Over		Incl.		Δdmp		Vdp	ΔBs (reference)		Kia (reference)	
mm	in.	mm	in.	High	Low	Max.	High	Low	Max.	
6	0.2362	10	0.3937	+12 (+5)	0	8 (3)	0	-120 (-47)	15 (6)	± 100 (± 39)
10	0.3937	18	0.7087	+15 (+6)	0	10 (4)	0	-120 (-47)	15 (6)	
18	0.7087	31.75	1.2500	+18 (+7)	0	12 (5)	0	-120 (-47)	18 (7)	
31.75	1.2500	50.8	2.0000	+21 (+8)	0	14 (6)	0	-120 (-47)	20 (8)	
50.8	2.0000	80	3.1496	+24 (+9)	0	16 (6)	0	-150 (-59)	25 (10)	
80	3.1496	120	4.7244	+28 (+11)	0	19 (7)	0	-200 (-79)	30 (12)	
120	4.7244	180	7.0866	+33 (+13)	0	22 (9)	0	-250 (-98)	35 (14)	
										—
										—

Theoretical tapered bore

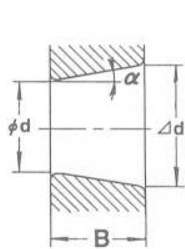

Actual tapered bore with deviation of mean bore diameter in plane of inner ring

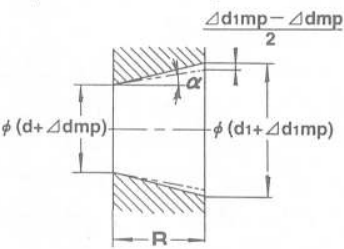

Table 1.2 Tolerances on inner rings of bearings with tapered bore

Unit: 0.001 mm
(0.0001 in.)

Nominal bore diameter d				Deviation of mean bore diameter in place of inner ring at the narrower edge		$\Delta d1mp - \Delta dmp$		Variation of bore diameter in plane of inner ring(1)
Over		Incl.		Δdmp		Vdp		
mm	in.	mm	in.	High	Low	Max.	Min.	
18	0.7087	30	1.1811	+33 (+13)	0	+21 (+8)	0	13 (5)
30	1.1811	50	1.9685	+39 (+15)	0	+25 (+10)	0	16 (6)
50	1.9685	80	3.1496	+46 (+18)	0	+30 (+12)	0	19 (7)
80	3.1496	120	4.7244	+54 (+21)	0	+35 (+14)	0	22 (9)
120	4.7244	180	7.0866	+63 (+25)	0	+40 (+16)	0	40 (16)

Note: (1) Applicable to all radial planes of tapered bore.

2) Outer rings

Table 1.3 Tolerances on outer rings Unit: 0.001 mm
(0.0001 in.)

Nominal outside diameter D				Deviation of mean outside diameter		Radial runout of outer ring
Over		Incl.		ΔDm		Kea (reference)
mm	in.	mm	in.	High	Low	Max.
18	0.7087	30	1.1811	0	-9 (-4)	15 (6)
30	1.1811	50	1.9685	0	-11 (-4)	20 (8)
50	1.9685	80	3.1496	0	-13 (-5)	25 (10)
80	3.1496	120	4.7244	0	-15 (-6)	35 (14)
120	4.7244	150	5.9055	0	-18 (-7)	40 (16)
150	5.9055	180	7.0866	0	-25 (-10)	45 (18)
180	7.0866	250	9.8425	0	-30 (-12)	50 (20)
250	9.8425	315	12.4016	0	-35 (-14)	60 (24)

Note: The values of the low of ΔDm shall not be applicable to the distance within 1/4 the width dimension of outer ring from the outer ring surface.

- 3) Distance between radial plane passing through center of sphere of outer ring and side of inner ring.

Table 1.4 Distance “n” between radial plane passing through center of sphere of outer ring and side of inner ring

Nominal bore diameter d				n	
Over		Incl.		Deviations	
mm	in.	mm	in.	mm (0.001 mm)	in. (0.0001 in.)
		50	1.9685	± 200	± 79
50	1.9685	80	3.1496	± 250	± 98
80	3.1496	120	4.7244	± 300	± 118
120	4.7244			± 350	± 138

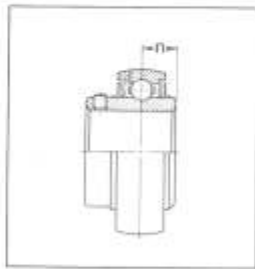

- 4) Chamfer dimensions

Table 1.5 Chamfer dimensions

Unit: mm (in.)

Nominal chamfer dimensions r	r	
	Max.	Min.
1 (.039)	1.5 (.059)	0.6 (.024)
1.5 (.059)	2 (.079)	1 (.039)
2 (.079)	2.5 (.098)	1.5 (.059)
2.5 (.098)	3 (.118)	2 (.079)
3 (.118)	3.5 (.138)	2.5 (.098)
3.5 (.138)	4 (.157)	2.5 (.098)
4 (.157)	4.5 (.177)	3 (.118)
5 (.197)	6 (.236)	4 (.157)

Note: Chamfer dimensions do not control the shape of the bearing corner, but the profile shall fall within the shaded area shown below.

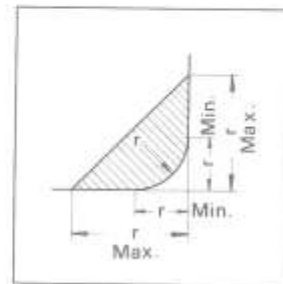

1.2 Tolerances for housings

- 1) Tolerances on spherical inside diameter of housings

Table 1.6 Tolerances on spherical inside diameter

Unit: 0.001 mm
(0.0001 in.)

Nominal diameter of spherical bearing seating Da				Tolerance range class H7			Tolerance range class J7			Tolerance range class K7		
				Deviation of mean bore diameter in plane of inner ring of spherical seat		Variation of bore diameter in plane of inner ring of spherical seat	Deviation of mean bore diameter in plane of inner ring of spherical seat		Variation of bore diameter in plane of inner ring of spherical seat	Deviation of mean bore diameter in plane of inner ring of spherical seat		Variation of bore diameter in plane of inner ring of spherical seat
Over		Incl.		Dam		VDap	Dam		VDap	Dam		VDap
mm	in.	mm	in.	High	Low	Max.	High	Low	Max.	High	Low	Max.
30	1.1811	50	1.9685	+25 (+10)	0	10 (4)	+14 (+6)	-11 (-4)	10 (4)	7 (3)	18 (7)	10 (4)
50	1.9685	80	3.1496	+30 (+12)	0	12 (5)	+18 (+7)	-12 (-5)	12 (5)	9 (4)	21 (8)	12 (5)
80	3.1496	120	4.7244	+35 (+14)	0	14 (6)	+22 (+9)	-13 (-5)	14 (6)	10 (4)	25 (11)	14 (6)
120	4.7244	180	7.0866	+40 (+16)	0	16 (6)	+26 (+10)	-14 (-6)	16 (6)	12 (5)	28 (11)	16 (6)
180	7.0866	250	9.8425	+46 (+18)	0	18 (7)	+30 (+12)	-16 (-6)	18 (7)	13 (5)	33 (13)	18 (7)
250	9.8425	315	12.4016	+52 (+20)	0	20 (8)	+36 (+14)	-16 (-6)	20 (8)	16 (6)	36 (14)	20 (8)

Note: (1) Dimensional tolerances on spherical inside diameter of housings are classified into H for clearance fit K for interference fit and J for intermediate fit between H and K. As the self-contained bearings are equipped with locking-pin, clearance fit H is normally applied.

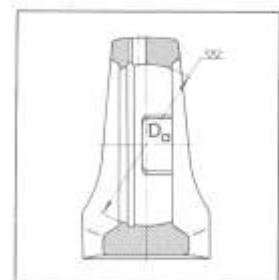

2) Tolerances for Pillow Block type housings (P, IP, PH)

Table 1.7 Pillow Block type housings (P, IP, PH)

Unit: 0.001 mm
(0.0001 in.)

Housing No.						h	e
						Deviations	Deviations
							IP200, IP300
P 203	—	—	—	—	—	± 150 (±59)	± 700 (± 276)
P 204	—	—	—	—	PH 204		
P 205	P 305	P X05	—	—	PH 205		
P 206	P 306	P X06	—	—	PH 206		
P 207	P 307	P X07	—	—	PH 207		
P 208	P 308	P X08	IP 208	—	PH 208		
P 209	P 309	P X09	IP 209	—	PH 209		
P 210	P 310	P X10	IP 210	—	PH 210		
P 211	P 311	P X11	IP 211	—	—	± 200 (±79)	± 1000 (± 394)
P 212	P 312	P X12	IP 212	—	—		
P 213	P 313	P X13	IP 213	IP 313	—		
P 214	P 314	P X14	—	IP 314	—		
P 215	P 315	P X15	—	IP 315	—		
P 216	P 316	P X16	—	IP 316	—		
P 217	P 317	P X17	—	IP 317	—		
P 218	P 318	P X18	—	IP 318	—		
—	P 319	—	—	IP 319	—		
—	P 320	P X20	—	IP 320	—		
—	P 321	—	—	—	—	± 300 (±118)	
—	P 322	—	—	IP 322	—		
—	P 324	—	—	IP 324	—		
—	P 326	—	—	IP 326	—		
—	P 328	—	—	IP 328	—		

Note: These tolerances also apply to Bearing Units with Covers.

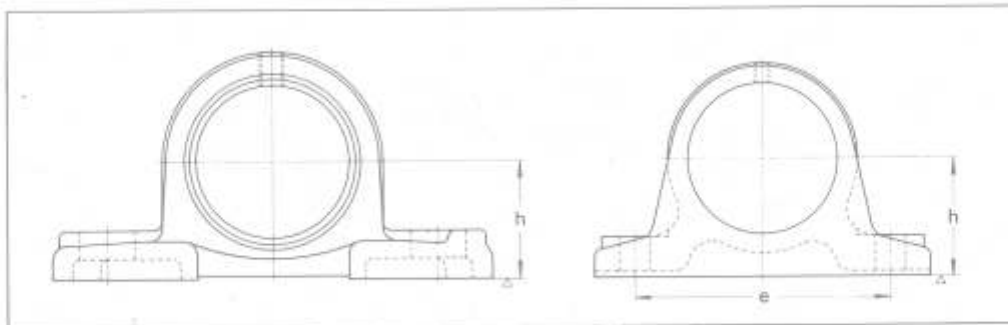

3) Tolerances for Flange type housings (F, FC, FS, FL, FK)

Table 1.8 Flange type housings (F, FC, FS, FL, FK)

Unit: 0.001 mm
(0.0001 in.)

Housing No.								e Deviations	I Deviations	Radial run-out of machined pilot Max.	F Deviations					
											FC 200		FS 300		FC X00	
											High	Low	High	Low	High	Low
F204	-	-	FC204	-	FL204	-	FK204	±700 (±276)	±500 (±197)	200 (79)	0	-46 (-18)	0	-46 (-18)	0	-46 (-18)
F205	F305	FX05	FC205	FS305	FL205	FL305	FK205				0	-54 (-21)	0	-54 (-21)	0	-54 (-21)
F206	F306	FX06	FC206	FS306	FL206	FL306	FK206				0	-54 (-21)	0	-54 (-21)	0	-54 (-21)
F207	F307	FX07	FC207	FS307	FL207	FL307	FK207	±1000 (±394)	±800 (±315)	300 (118)	0	-63 (-25)	0	-63 (-25)	0	-63 (-25)
F208	F308	FX08	FC208	FS308	FL208	FL308	FK208				0	-72 (-28)	0	-72 (-28)	0	-72 (-28)
F209	F309	FX09	FC209	FS309	FL209	FL309	FK209				0	-72 (-28)	0	-72 (-28)	0	-72 (-28)
F210	F310	FX10	FC210	FS310	FL210	FL310	FK210	400 (157)	-	-	0	-81 (-32)	-	-	-	-
F211	F311	FX11	FC211	FS311	FL211	FL311	FK211				0	-89 (-35)	-	-	-	-
F212	F312	FX12	FC212	FS312	FL212	FL312	-				0	-89 (-35)	-	-	-	-
F213	F313	FX13	FC213	FS313	FL213	FL313	-	-	-	-	0	-81 (-32)	-	-	-	-
F214	F314	FX14	FC214	FS314	FL214	FL314	-				0	-89 (-35)	-	-	-	-
F215	F315	FX15	FC215	FS315	FL215	FL315	-				0	-89 (-35)	-	-	-	-
F216	F316	FX16	FC216	FS316	FL216	FL316	-	-	-	-	0	-81 (-32)	-	-	-	-
F217	F317	FX17	FC217	FS317	FL217	FL317	-				0	-89 (-35)	-	-	-	-
F218	F318	FX18	FC218	FS318	FL218	FL318	-				0	-89 (-35)	-	-	-	-
-	F319	-	-	FS319	-	FL319	-	-	-	-	0	-81 (-32)	-	-	-	-
-	F320	FX20	-	FS320	-	FL320	-				0	-89 (-35)	-	-	-	-
-	F321	-	-	FS321	-	FL321	-				0	-89 (-35)	-	-	-	-
-	F322	-	-	FS322	-	FL322	-	-	-	-	0	-81 (-32)	-	-	-	-
-	F324	-	-	FS324	-	FL324	-				0	-89 (-35)	-	-	-	-
-	F326	-	-	FS326	-	FL326	-				0	-89 (-35)	-	-	-	-
-	F328	-	-	FS328	-	FL328	-	-	-	-	0	-81 (-32)	-	-	-	-
-	-	-	-	-	-	-	-				0	-89 (-35)	-	-	-	-
-	-	-	-	-	-	-	-				0	-89 (-35)	-	-	-	-

Note: (1) Radial run-out of machined pilot applies to Flange Cartridge Units.
 (2) These tolerances also apply to Bearing Units with Covers.
 (3) For FC X00 and FL X00 types, tolerances for F X00 shall be applied.

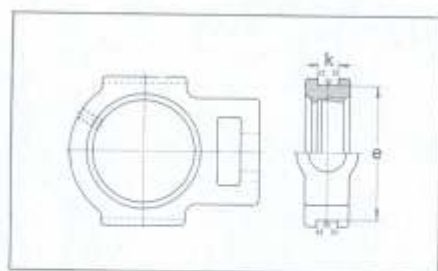
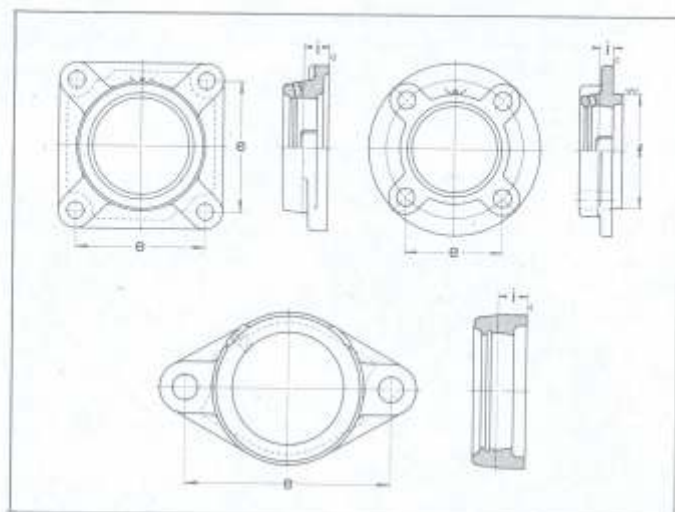

4) Tolerances for Take-Up type housings (T)

Table 1.9 Take-Up type housings (T)

Unit: 0.001 mm
(0.0001 in.)

Housing No.			k Deviations	e Deviations	Parallelism of guide Max.
T204	-	-	+200 0	0 -500	500 (197)
T205	T305	TX05			
T206	T306	TX06			
T207	T307	TX07	(+79) 0	0 (-197)	-
T208	T308	TX08			
T209	T309	TX09			
T210	T310	TX10	-	-	600 (236)
T211	T311	TX11			
T212	T312	TX12			
T213	T313	TX13	+300 0	0 -800	-
T214	T314	TX14			
T215	T315	TX15			
T216	T316	TX16	(+118) 0	0 (-315)	700 (276)
T217	T317	TX17			
-	T318	-			
-	T319	-	-	-	800 (315)
-	T320	-			
-	T321	-			
-	T322	-	-	-	-
-	T324	-			
-	T326	-			
-	T328	-	-	-	-
-	-	-			
-	-	-			

Note: These tolerances also apply to Bearing Units with Covers.

2. LOAD AND LIFE OF BEARING UNITS

As load capacity and life of Bearing Units are same as those of the self-contained bearing, they are calculated in the same method as ordinary ball bearings.

2.1 Bearing loads

1) Dynamic factors

In general, bearings are subjected to weight of rolling elements themselves, forces due to belt or gear drive and various kinds of loads produced by operation of the machine. Besides them, operation of the machine is accompanied by shocks and vibrations, small or heavy, and it is practically difficult to obtain these loads specifically by calculations.

Therefore, the loads on the self-contained bearing are to be obtained by multiplying calculable values by factors which are determined through experiences. These factors are generally classified as follows and called Dynamic Factors collectively.

- Belt factor f_b : Belt (or chain) drive
- Gear factor f_g : Gear drive
- Machine factor f_d : All types of drive

(1) Belt (or chain) drive

The radial load imposed on the pulley (or sprocket) shaft by belt or chain drive is calculated as follows.

$$M = 97400 \frac{H}{n} \quad (2.1)$$

$$K_b = \frac{M}{r} \quad (2.2)$$

where:

- M : Torque on pulley (or sprocket) kgfcm
- H : Input horsepower kW
- n : Shaft speed rpm
- K_b : Effective tension of belt (or chain) kgf
- r : Effective radius of pulley (or sprocket) cm

The effective tension is the difference between tight-side tension and slack-side tension.

The radial load acting on the shaft through the pulley is obtained by multiplying the effective tension by belt (or chain) factor shown in Table 2.1 in consideration of type of the belt and starting tension.

$$F_b = f_b \cdot K_b \quad (2.3)$$

where:

- F_b : Radial load on pulley (or sprocket) shaft kgf
- f_b : Belt (or chain) factor

Table 2.1 Belt (or chain) factor : f_b

Type of belt	f_b
V belt	2~2.5
Single leather belt with tension pulley	2.5~3
Double-ply leather belt with tension pulley	3~3.5
Silk belt	3.5~4.5
Single leather or rubber belt	4~5
Double-ply leather or hemp belt	5~6
Chain	1.25~1.5

Note: The shorter the distance between shafts and the lower the speed, the larger factor be taken.

(2) Gear drive

Operating load on the gear at gear drive can be theoretically obtained from transmission horsepower and type of the gear.

Although the flat gear is subjected only to the radial load, worm gear, bevel gear and screw gear are subjected to the thrust load in addition to the radial load. Besides them, the gears are necessarily subject to shock and vibration loads which are produced according to machining degree of finish of gear teeth.

However, as it is difficult to calculate these loads accurately, the load on the gear shaft is obtained by multiplying theoretical loads by gear factors given in Table 2.2.

$$F_g = f_g \cdot K_g \quad (2.4)$$

where:

- F_g : Radial load on gear shaft kgf
- K_g : Theoretical load on gear shaft kgf
- f_g : Gear factor

Table 2.2 Gear factor : f_g

Type of gear	f_g
Precision gear (tolerance of pitch and shape is within 0.02mm)	1.05~1.1
Ordinary gear (tolerance of pitch and shape is within 0.02~0.1mm)	1.1~1.3

2.2 Life and load rating

1) Life and basic dynamic load rating

Bearings are incessantly subjected to repetitive stresses on outer and inner rings and rolling elements during operation even if they are normally run and there eventually occur flakings in raceways and surfaces of rolling elements due to fatigue.

The bearing life is expressed in total numbers of revolution (or hours at constant speed) which a bearing attains before fatigue failure occurs on either bearing race or rolling element.

As there is variation in the lives of identical bearings operating under the same condition, the bearing life is defined as total numbers of revolution (or hours at constant speed) which 90% of group of identical bearings attain or exceed before the onset of fatigue failure when individual bearings are operated under the same condition. This life of the bearing is called Rating Life which is about 1/5 of average life of the bearing. Basic dynamic load rating represents such load that does not vary in magnitude and direction and under which rating life of the bearing will be one million revolutions with the inner ring rotating and the outer ring stationary. For the self-contained bearing for Bearing Units, central radial load is taken as the basic dynamic load rating.

2) Calculation of rating life

Relation among rating life, basic dynamic load rating and operating load on the bearing is formularized as follows.

$$L = \left(\frac{C}{P}\right)^3 \tag{2.8}$$

where:

- L : Rating life 10⁶ rev
- C : Basic dynamic load rating kg
- P : Dynamic equivalent load kg

When it is convenient to express rating life in hours rather than numbers of revolution, following formula is used.

$$L_h = \frac{10^6 \cdot L}{60 \cdot n} = \frac{10^6}{60 \cdot n} \left(\frac{C}{P}\right)^3 \tag{2.9}$$

where:

- Lh : Life hours of bearing h
- n : Shaft speed rpm

Fig. 2.1 NOMOGRAPH (n-C/P-Lh)

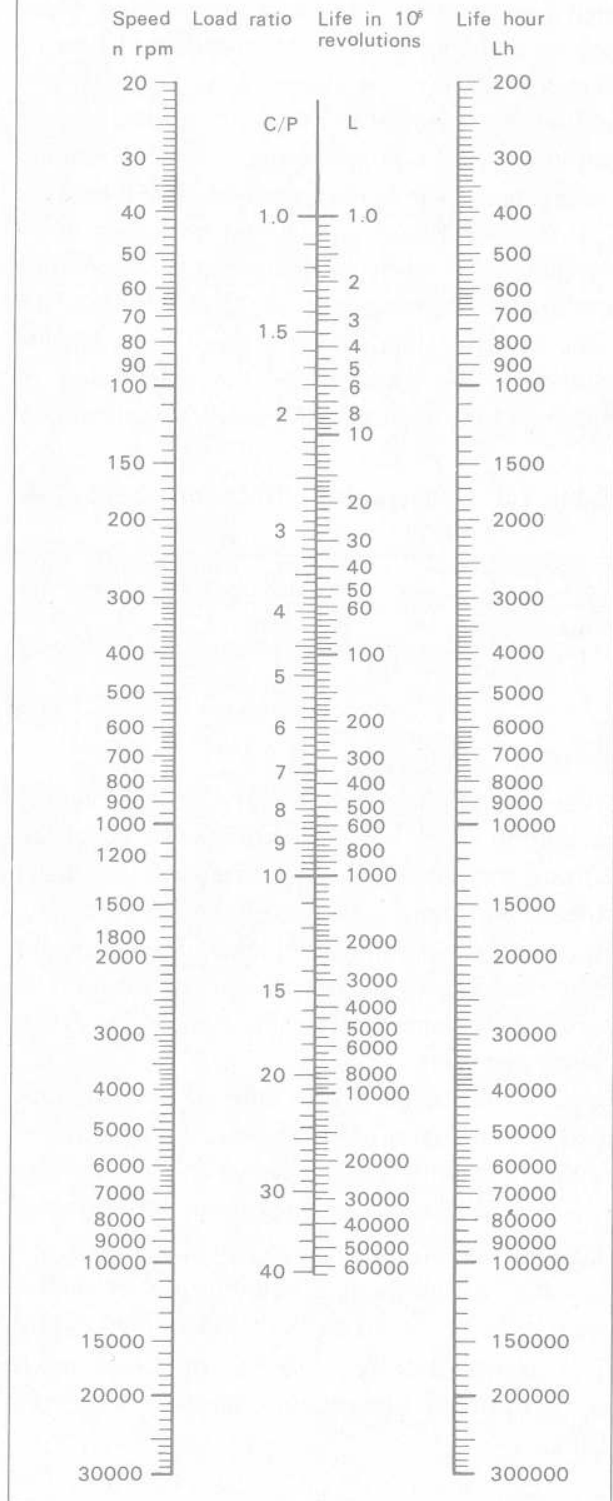

For life calculation of the bearing, the Nomograph shown in Fig. 2.1 which represents a relation between C/P value and rating life may be conveniently used.

3. MOUNTING OF BEARING UNITS ON SHAFT

Bearing Units are prelubricated for immediate installation and operation providing easy handling of them, but same as ordinary bearings, they may come to early failure when not handled properly.

Bearing Units must be, therefore, handled with care and when mounting on the shaft, be careful not to apply shock loads nor permit ingress of foreign matters into the self-contained bearing.

3.1 Selection of shaft

The shaft on which Bearing Units are mounted shall be free from bend and flexure.

For the units with cylindrical bore (with set-screws or eccentric locking collar) clearance fit is

usually adopted for mounting the units on the shaft, and shaft tolerances in Table 3.1 are recommended for such loose fit. But, for high speed or highly accurate operation or such application where is accompanied by heavy shock loads, interference fit is to be adopted. Table 3.2 shows recommended shaft tolerances for interference fit. When Bearing Units with eccentric locking collar are mounted on the shaft with interference fit, the eccentric locking collar may be omitted.

Tapered bore bearings permit wider tolerances of the shaft since they are locked to the shaft by means of adapter sleeves.

Recommended shaft tolerances for tapered bore bearings are listed in Table 3.3.

Table 3.1 Shaft tolerances for clearance fit for bearings with cylindrical bore

Unit: 0.001mm
(0.0001in.)

Shaft diameter				Shaft tolerance					
Over		Incl.							
mm	in.	mm	in.	j7		h7		h8	
10	0.3937	18	0.7087	+12 (+5)	-6 (-2)	0	-18 (-7)	0	-27 (-11)
18	0.7087	30	1.1811	+13 (+5)	-8 (-3)	0	-21 (-8)	0	-33 (-13)
30	1.1811	50	1.9685	+15 (+6)	-10 (-4)	0	-25 (-10)	0	-39 (-15)
50	1.9685	80	3.1496	+18 (+7)	-12 (-5)	0	-30 (-12)	0	-46 (-18)
80	3.1496	120	4.7244	+20 (+8)	-15 (-6)	0	-35 (-14)	0	-54 (-21)
120	4.7244	140	5.5118	+22 (+9)	-18 (-7)	0	-40 (-16)	0	-63 (-25)

Note: Use j7 in principle.

Table 3.2 Shaft tolerances for interference fit for bearings with cylindrical bore

Unit: 0.001mm
(0.0001in.)

Shaft diameter				Shaft tolerance							
Over		Incl.									
mm	in.	mm	in.	n6		n7		m6		m7	
10	0.3937	18	0.7087	+23 (+9)	+12 (+5)	+30 (+12)	+12 (+5)	+18 (+7)	+7 (+3)	+25 (+10)	+7 (+3)
18	0.7087	30	1.1811	+28 (+11)	+15 (+6)	+36 (+14)	+15 (+6)	+21 (+8)	+8 (+3)	+29 (+11)	+8 (+3)
30	1.1811	50	1.9685	+33 (+13)	+17 (+7)	+42 (+17)	+17 (+7)	+25 (+10)	+9 (+4)	+34 (+13)	+9 (+4)
50	1.9685	80	3.1496	+39 (+15)	+20 (+8)	+50 (+20)	+20 (+8)	+30 (+12)	+11 (+4)	+41 (+16)	+11 (+4)
80	3.1496	120	4.7244	+45 (+18)	+23 (+9)	+58 (+23)	+23 (+9)	+35 (+14)	+13 (+5)	+48 (+19)	+13 (+5)
120	4.7244	140	5.5118	+52 (+21)	+27 (+11)	+67 (+26)	+27 (+11)	+40 (+16)	+15 (+6)	+55 (+22)	+15 (+6)

Note: Use m6 for shaft diameter less 30mm.

Table 3.5 Recommended set-screw tightening torque for through-hardened units

Set-screw tap		Bearing No.				Tightening torque	
Metric thread	UNF thread					kgcm	inlb
M 5 X 0.8	10-32	UCW 201-203			B 1-3	25	22
M 6 X 0.75	1/4-28	UC 201-203	UC 305-306	UC X05		40	35
M 8 X 1	5/16-24		UC 307	UC X06-X08		85	74
M 10 X 1.25	3/8-24		UC 308-309	UC X09-X12		165	143
M 12 X 1.5	1/2-20	UC 214-218	UC 310-314	UC X13-X17		285	247
M 14 X 1.5	5/8-18		UC 315-316	UC X18		285	247
M 16 X 1.5	3/4-18		UC 317-319	UC X20		680	590
M 18 X 1.5	7/8-16		UC 320-324			680	590
M 20 X 1.5	1-14		UC 326-328			1150	998

Bearing Units with set-screws are mounted on the shaft in following steps.

- (1) Make sure that the set-screws do not protrude from the inside diameter of the self-contained bearing. (In case they protrude, loosen the set-screws).
- (2) Slowly slide Bearing Units on the shaft in required position. When mounting, be careful of shaft distortion and never hammer the ends of the bearing inner ring and the slinger.
- (3) Tighten the set-screws uniformly with recommended torque in Table 3.4 and fix the units to the shaft.
- (4) Fix the housing to the machine frame. The machine frame must be rigid enough and flat to prevent housing from being deformed.

2) Bearing Units with adapter sleeve

Bearing Units with adapter sleeve permit wider shaft tolerances and can be used in applications where vibrations and shocks are heavy.

Mounting processes of these units are as follows.

- (1) Slip the adapter sleeve on the shaft into required position.
- (2) Slide the unit on the shaft and mate the tapered bore of the self-contained bearing to counter tapered part of the sleeve.
- (3) Fit the washer and nut to the sleeve and tighten the nut by hand.
- (4) Tighten the nut with the spanner to fix the unit to the shaft.

Be careful not to tighten the nut too hard as it may cause overheating.

- (5) Bend a tooth of the washer into the notch of the sleeve to prevent the nut from loosening.
- (6) Fix the housing to the machine frame in the same manner as the units with set-screws.

3) Bearing Units with eccentric locking collar
Bearing Units with eccentric locking collar are mounted on the shaft by engaging the eccentric locking collar with the eccentric recessed cam in the bearing inner ring as shown in Fig. 3.5. For tightening of the collar, turn it in the direction of shaft rotation and the collar tightens automatically with the force corresponding to operating radial loads.

Then, fix the collar to the shaft by tightening the set-screws. For recommended tightening torque of the set-screws, refer to Table 3.6.

If the collar is turned to opposite direction to shaft rotation, the inner ring loosens after starting operation, then it tightens automatically in the direction of shaft rotation. The shaft may, therefore, slide in the bearing bore when the units are subjected to thrust loads.

For applications where the shaft rotates in clockwise direction and counter-clockwise direction reciprocally, it is needed to use the shaft with shoulder or the axial direction fixing collar to fix the bearing inner ring. When the inner ring has interference fit to the shaft, the eccentric locking collar may be omitted, but if the units are subjected to thrust loads, the inner ring must be fixed in the direction of shaft rotation, and in case especially heavy thrust loads operate, the shaft with shoulder must be used.

Table 3.6 Set-screw tightening torque

Set-screw tap		Bearing No.		Tightening torque	
Metric thread	UNF thread			kgcm	inlb
M5X0.8	10-32	UD 204 +EE	30	26	
M6X0.75	1/4-28	UD 205 +EE -206 +EE	50	43	
M8X1	5/16-24	UD 207 +EE -210 +EE	120	104	

4) Bearing Units with covers

Mounting processes of Bearing Units with cast iron and pressed steel covers are as follows.

- (1) When the cast iron or pressed steel covers are equipped with rubber seals, fill the chamber inside the covers with the grease by about $1/3 \sim 1/2$ full. The grease, which is to be rather solid type like the cup grease, serves for prevention of ingress of dirt and moisture from the atmosphere. (Fig. 3.4).
For the rubber seal of the pressed cover, fill the grease in the space between lips and apply the grease to surface of the shaft on the part where the lips contact.
- (2) Slide the inner cover with the rubber seal on the shaft to required position.
- (3) Mount the unit without cover on the shaft in required position and lock it there positively. Mounting processes of the units with covers on the shaft are same as those with set-screws or adapter sleeve.
- (4) Fix the housing to the shaft by fixing bolts.
- (5) Fix the inside cover with rubber seal to the

housing by fitting it to the counter recess in the housing and tighten it with the hexagonal bolts for cast iron cover. The pressed steel cover is to be pressed into the recess in the housing. When fixing the pressed steel cover, use a wooden or plastic hammer as shown in Fig. 3.5.

- (6) Fix another cover with the rubber seal or the closed cover to the housing in the same method as above (5).

When removing the pressed steel covers, use a screw driver as shown in Fig. 3.6.

The rubber seal equipped in the cover often contacts comparatively rough unground surface of the shaft and dirt and other contaminants enter between the lips of the rubber seal. The rubber seal of the cover may be, therefore, damaged earlier than the rubber seal of the self-contained bearing and it is needed to replace the rubber seal of the cover from time to time. It is also desirable to chamfer the end of the shaft so that it may not damage the rubber seal when mounting the units on the shaft.

Fig. 3.4

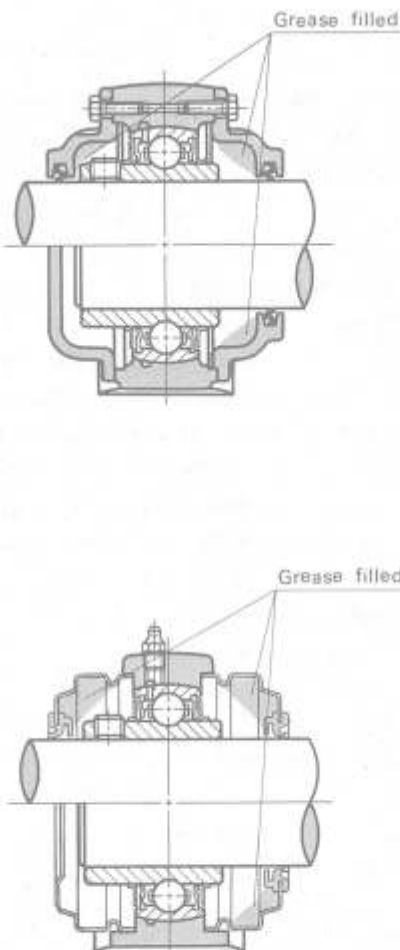

Fig. 3.5

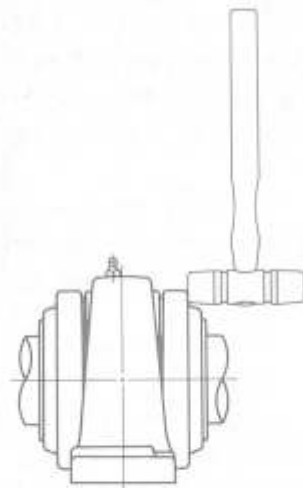
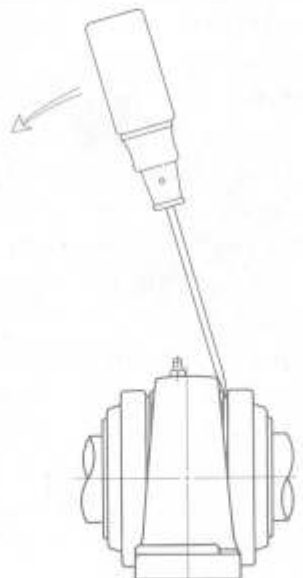

Fig. 3.6



3.3 Inspection

When mounting of Bearing Units is completed, inspect if they are mounted properly. For inspection, turn the shaft by hand and check if it rotates smoothly. If no irregularity is found, run the units by the motor initially at low speed under no load, then increase speed and load up to required conditions gradually and check noise and rise of temperature during this operation.

1) Noise

To inspect noise, apply a screw driver to the housing and listen to rotating sound. If there is irregularity in mounting, etc., abnormal noise can be heard.

2) Rise of temperature

Measure the temperature on surface of the bearing inner ring and the housing during operation. Generally, the temperature rises up to a constant degree and it is stabilized in 2~3 hours after starting operation. But, if the units are mounted improperly, or by other irregularities, the temperature rises extremely and is not stabilized in due time.

The above are to be checked during running-in operation and making sure of no irregularity existing, start regular operation of the machine. It is desirable to inspect noise and rise of temperature periodically during regular operation so that any failure may be found early.

3.4 Allowance for shaft expansion

As Bearing Units are locked to the shaft by means of set-screw, adapter sleeve or eccentric locking collar and as spherical outside diameter of the bearing outer ring mates corresponding spherical seat of the housing, allowance for shaft expansion is quite limited compared with ordinary bearings.

Where distance between the units is short and expansion of the shaft due to heat is not expected, allowance for shaft expansion is not needed. But, in applications where the units are used in high atmospheric or operating temperature or where the units are mounted on the long shaft, the units may come to failure due to

thrust loads produced by shaft expansion unless allowance for such expansion of the shaft is provided.

When the units are to be used under such operating conditions as may cause shaft expansion, the unit on the fixed side is to be locked to the shaft firmly and the one on the other side is to be locked to the shaft by means of SH type set-screw on the part where a keyway is provided so that the shaft may expand in axial direction as shown in Fig. 3.7 or Cartridge Unit may be used as shown in Fig. 3.8. Although the former method is popularly adopted for such applications, use of Cartridge Units is desirable. For applications where shaft expansion is a factor, UCEP 200 type is available.

When SH type set-screw is used for the shaft with a key-way, recommended shaft tolerances are h7 or h8.

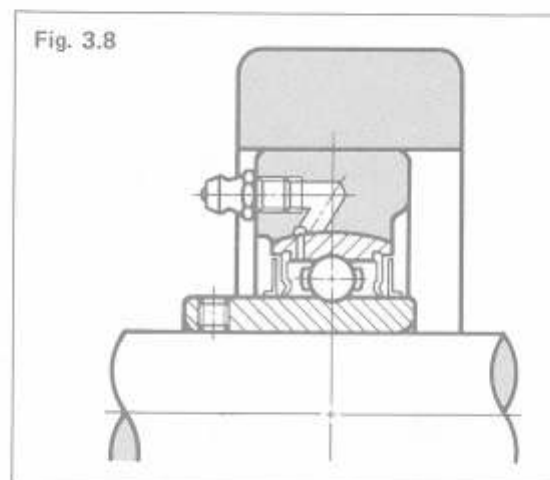
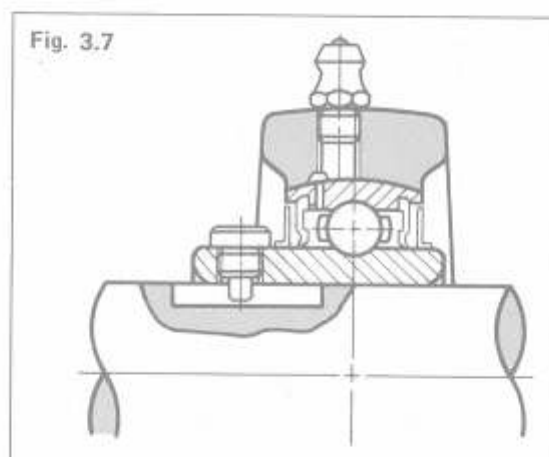

3.5 Radial internal clearance

Radial internal clearance of the self-contained bearing is specified as listed in Table 3.7 for cylindrical bore and Table 3.8 for tapered bore. Ordinary clearance (C0) is considered to be satisfactory for most applications of the units, but when the units are operated in high atmos-

pheric temperature or when temperature differential between the inner ring and the outer ring is large due to effect of the heat transmitted through the shaft or when rise of temperature is high due to high speed operation, larger clearance must be adopted for initial clearance.

Table 3.7 Radial internal clearance for bearings with cylindrical bore (with set-screws and eccentric locking collar)

Unit: 0.001mm
(0.0001in.)

Nominal bore diameter d				Clearance symbol										Measuring load	
Over		Incl.		C2		C0		C3		C4		C5			
mm	in.	mm	in.	Min.	Max.	Min.	Max.	Min.	Max.	Min.	Max.	Min.	Max.		
10	0.3937	18	0.7087	—	9	3	18	11	25	18	33	—	—	2.5	5.51
					(3.5)	(1)	(7)	(4)	(10)	(7)	(13)				
18	0.7087	24	0.9449	—	10	5	20	13	28	20	36	—	—	5	11.02
					(4)	(2)	(8)	(5)	(11)	(8)	(14)				
24	0.9449	30	1.1811	—	11	5	20	13	28	23	41	36	56	5	11.02
					(4.5)	(2)	(8)	(5)	(11)	(9)	(16)	(14)	(22)		
30	1.1811	40	1.5748	—	11	6	20	15	33	28	46	41	61	5	11.02
					(4.5)	(2)	(8)	(6)	(13)	(11)	(18)	(16)	(24)		
40	1.5748	50	1.9685	—	11	6	23	18	36	30	51	46	69	5	11.02
					(4.5)	(2)	(9)	(7)	(14)	(12)	(20)	(18)	(27)		
50	1.9685	65	2.5591	—	15	8	28	23	43	38	61	56	81	15	33.07
					(6)	(3)	(11)	(9)	(17)	(15)	(24)	(22)	(32)		
65	2.5591	80	3.1496	—	15	10	30	25	51	46	71	67	97	15	33.07
					(6)	(4)	(12)	(10)	(20)	(18)	(28)	(26)	(38)		
80	3.1496	100	3.9370	—	18	12	36	30	58	53	84	79	114	15	33.07
					(7)	(5)	(14)	(12)	(23)	(21)	(33)	(31)	(45)		
100	3.9370	120	4.7244	—	20	15	41	36	66	61	97	92	132	15	33.07
					(8)	(6)	(16)	(14)	(26)	(24)	(38)	(36)	(52)		
120	4.7244	140	5.5118	—	23	18	48	41	81	71	114	104	154	15	33.07
					(9)	(7)	(19)	(16)	(32)	(28)	(45)	(41)	(61)		

Table 3.8 Radial internal clearance for bearings with tapered bore (with adapter sleeve)

Unit: 0.001mm
(0.0001in.)

Nominal bore diameter d				Clearance symbol								Measuring load	
Over		Incl.		CT2		CT0		CT3		CT4			
mm	in.	mm	in.	Min.	Max.	Min.	Max.	Min.	Max.	Min.	Max.		
24	0.9449	30	1.1811	5	20	13	28	23	41	36	56	5	11.02
				(2)	(8)	(5)	(11)	(9)	(16)	(14)	(22)		
30	1.1811	40	1.5748	6	20	15	33	28	46	41	61	5	11.02
				(2)	(8)	(6)	(13)	(11)	(18)	(16)	(24)		
40	1.5748	50	1.9685	6	23	18	36	30	51	46	69	5	11.02
				(2)	(9)	(7)	(14)	(12)	(20)	(18)	(27)		
50	1.9685	65	2.5591	8	28	23	43	38	61	56	81	15	33.07
				(3)	(11)	(9)	(17)	(15)	(24)	(22)	(31)		
65	2.5591	80	3.1496	10	30	25	51	46	71	67	97	15	33.07
				(4)	(12)	(10)	(20)	(18)	(28)	(26)	(38)		
80	3.1496	100	3.9370	12	36	30	58	53	84	79	114	15	33.07
				(5)	(14)	(12)	(23)	(21)	(33)	(31)	(45)		
100	3.9370	120	4.7244	15	41	36	66	61	97	92	132	15	33.07
				(6)	(16)	(14)	(26)	(24)	(38)	(36)	(52)		
120	4.7244	140	5.5118	18	48	41	81	71	114	104	154	15	33.07
				(7)	(19)	(16)	(32)	(28)	(45)	(41)	(61)		

4. LUBRICATION OF BEARING UNITS

4.1 Limiting speed

The limiting speed of the bearing is dependent upon type and size of the bearing, type of lubricant, method of lubrication, etc. and it is generally expressed in terms of "dn value" (bore in mm x rpm) or "dmn value" ($\frac{d+D}{2}$ in mm x rpm).

The self-contained bearing for Bearing Units has a deep grooved internal construction, but as it is sealed by rubber seals on both sides retaining the grease inside it, the speed capacity is limited according to linear contact velocity of the seal. The limiting speed of Bearing Units with Covers corresponds to linear contact velocity of the rubber seals equipped in the cover.

The speed capacity of Bearing Units is, therefore, determined in consideration of these factors and the limiting speed of specific self-contained bearing is shown in Fig. 4.1

4.2 Relubrication

Bearing Units are all grease lubricated and are basically to be relubricated. The grease injected from the grease fitting by means of the grease gun flows into the bearing chamber passing through the grease groove in the housing and grease hole in the bearing outer ring.

For relubrication, it is recommended to supply the grease during operation of Bearing Units so as to avoid excessive greasing and the quantity of the grease to be supplied is about 80% of the standard fill volume at factory lubrication.

There are three types of the grease fittings available as shown in Table 4.1 and Fig. 4.2 and convenient type is to be selected according to mounting position of Bearing Units.

Fig. 4.1

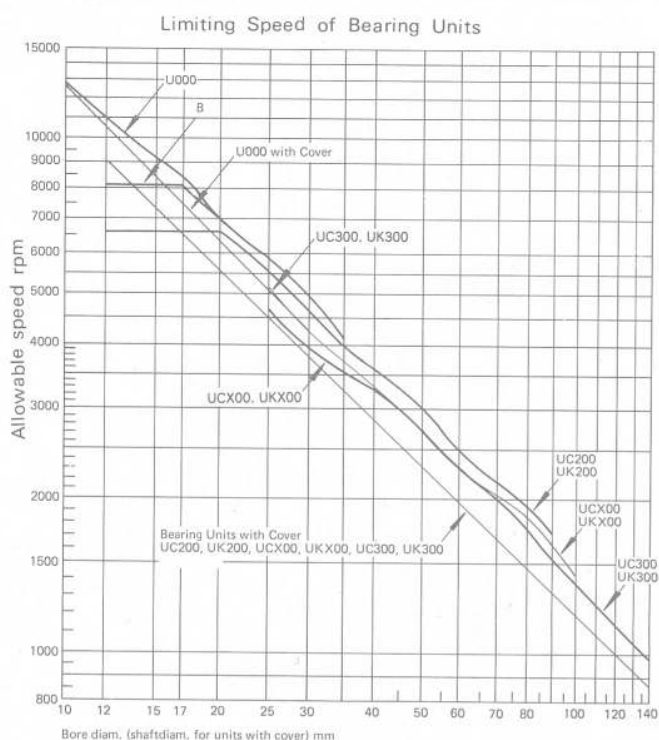
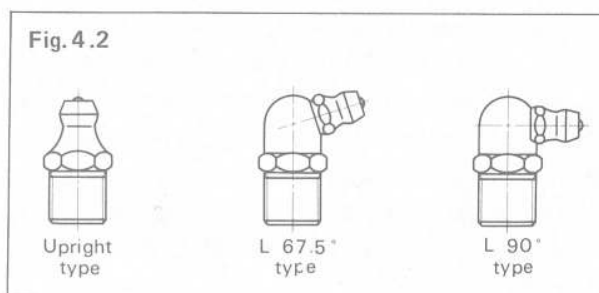

Table 4.1 Type of grease fitting

No.	Type	Thread	Applicable housing	
			Type	No.
GU1	Upright	1/4-28UNF	P, IP, PH, EP F, FC, FS, FL, FA, FK, C, ECH	201 ~ 213
				305 ~ 313
				X05 ~ X13
G1	Upright	PF 1/8	T	214 ~ 218
				314 ~ 328
				X14 ~ X20
GU2	L 67.5°	1/4-28UNF	T	201 ~ 213
				305 ~ 313
				X05 ~ X13
G2	L 67.5°	PF 1/8	T	214 ~ 217
				314 ~ 328
				X14 ~ X17

Note: RP 200 type housing is equipped with G1 for all sizes.

Fig. 4.2



When many units are installed in a machine, centralized forced lubrication system is often adopted for regular relubrication, but in this case, failures by over-heating may be caused because standard type Bearing Units are not furnished with grease discharge holes. However, where operating speed is low and frequency of relubrication is less, standard type units may be used. For forced relubrication, the grease with viscosity of 385 ~ 310 (NLGI No. 0 or 1) is recommended.

Although Bearing Units are relubricable, grease relubrication is not always required according to operating condition.

Where environments are clean and operating temperature does not rise high, supplement of the grease may not be required like ordinary bearings, however, the grease becomes deteriorated in any operating condition and regular relubrication is necessarily required where operating condition is humid or rise of temperature is high.

4.3 Grease

1) Selection of grease

As bearings are to be operated for rather long time without supplement of the grease, the grease must be of high quality.

When selecting the grease, care must be taken not to use improper grease as there are various types of grease available by mixing mineral oil and metallic soap base according to the application purpose. The lithium soap base grease is superior to others in water-proof, heat-resistance and mechanical stability and can be used in both high and low temperature operating condition. For relubrication of Bearing Units, it is desirable to use the grease with the same soap base as that originally filled.

2) Quantity of grease

Quantity of the grease required for relubrication of the self-contained bearing is such that prevents metal-to-metal contact between raceways and steel balls and retainer and steel balls, lubricates friction parts of the seal and prevents ingress of dirt and moisture from the atmosphere.

3) Greasing interval

Greasing intervals for Bearing Units vary widely according to type and quality of the grease as well as operating condition, but in applications under normal conditions it is recommended to relubricate them at less than half of the value obtained from the following formula.

$$\log L = 4.73 - (t - 17.2) (0.0104 + 8.46 \times 10^{-7} n) - 0.03 \frac{nFr^{1.5}}{C^{1.9}} \quad (4. 1)$$

where :

L	: Average life of grease	h
t	: Operating temperature of bearing	°C
n	: Shaft speed	rpm
Fr	: Radial load	kg
C	: Basic dynamic load rating of bearing	kg

Table 4.2 Greasing interval

Operating temperature of bearing		Greasing interval		
		Environmental condition		
°C	°F	Clean	Dirty	Very dirty heavily humid
50	122	3 years	6 months	3 months
70	158	1 year	2 months	1 month
100	212	3 months	2 weeks	1 week
120	248	6 weeks	1 week	3 days
150	302	2 weeks	3 days	Daily

4.4 Range of operating temperature

As Bearing Units are used not only in normal temperature but also in high or low temperature in many applications.

Bearing Units for heat-resistance or cold-resistance application are available by using suitable kind of rubber seal and grease for specific operating temperature as shown in Table 4.3.

For heat-resistance application, decrease of load rating of the bearing must be taken into consideration and larger radial internal clearance of the bearing than normal application be taken.

Standard radial internal clearances for heat-resistance application are C3 HR4 and C4 HR5 for cylindrical bore bearing, and CT3 HR4 and CT4 HR5 for tapered bore bearing.

When temperature differential between bearing inner ring and outer ring is extremely large, suitable radial internal clearance must be determined.

Note: For application where operating temperature exceeds 150°C, consult us along with data of specification and operating condition.

Table 4.3 Range of operating temperature

Type	Range of operating temperature °C (°F)	Grease	Rubber seal	Color of slinger
Ordinary application	-15 to +100 (+5 to +212)	Alvania Grease 3 (Shell)	Nitril rubber (NBR)	Black
Heat resistance application HR 4	Normal to +120 (Normal to +248)	Super-Lube No. 3 (Yuken Kogyo Co., Ltd.)	Nitril rubber (NBR)	Yellow
Heat resistance application HR 5	Normal to +200 (Normal to +392)		Silicon rubber	
Cold resistance application CR 2A	-40 to Normal (-40 to Normal)	Aero Shell 7 (Shell)	Silicon rubber	Silver

LOAD RATING DATA

The following tables show Bearing Load Ratings at various rpm based on 500 hours minimum life – 2,500 hours average life.

Light, Normal and Medium duty type

Bearing No.						Radial load rating at various rpm														rpm
UC 200 UK 200	UC X00 UK X00	UD 200	B	UG 200	KH 200	33 1/3	50	100	250	500	750	1000	1200	1500	2000	2400	3600	5000		
(UCW 200) (201 ~ 203)	—	—	1 ~ 3	201 ~ 203	1 ~ 3	975 (2150)	850 (1880)	675 (1490)	500 (1100)	395 (870)	345 (760)	315 (690)	295 (650)	275 (605)	250 (550)	235 (515)	205 (450)	185 (405)		
201 ~ 204	—	204	4	204	204	1310 (2890)	1150 (2520)	910 (2000)	670 (1480)	530 (1170)	645 (1020)	420 (930)	395 (875)	370 (810)	335 (740)	315 (695)	275 (605)	245 (545)		
205	—	205	5	205	205	1430 (3150)	1250 (2750)	990 (2190)	730 (1610)	580 (1280)	505 (1120)	460 (1020)	435 (955)	400 (885)	365 (805)	345 (760)	300 (660)	270 (595)		
206	X05	206	6	206	206	2000 (4410)	1750 (3850)	1390 (3060)	1020 (2250)	810 (1790)	710 (1560)	645 (1420)	605 (1340)	560 (1240)	510 (1130)	480 (1060)	420 (925)	375 (830)		
207	X06	207	7	207	207	2640 (5820)	2310 (5090)	1830 (4040)	1350 (2970)	1070 (2360)	935 (2060)	850 (1870)	800 (1760)	740 (1640)	675 (1490)	635 (1400)	555 (1220)			
208	X07	208	—	208	208	2990 (6590)	2610 (5760)	2070 (4570)	1530 (3370)	1210 (2670)	1060 (2340)	960 (2120)	905 (2000)	840 (1850)	765 (1680)	720 (1590)	630 (1380)			
209	X08	209	—	209	209	3350 (7390)	2930 (6450)	2320 (5120)	1710 (3770)	1360 (3000)	1190 (2620)	1080 (2380)	1010 (2240)	940 (2080)	855 (1890)	805 (1780)	705 (1550)			
210	X09	210	—	210	210	3600 (7940)	3150 (6930)	2500 (5500)	1840 (4060)	1460 (3220)	1280 (2810)	1160 (2550)	1090 (2400)	1010 (2230)	920 (2030)	865 (1910)	755 (1670)			
211	X10	—	—	—	211	4400 (9700)	3840 (8480)	3050 (6730)	2250 (4960)	1780 (3930)	1560 (3440)	1420 (3120)	1330 (2940)	1240 (2730)	1120 (2080)	1060 (2330)				
212	X11	—	—	—	—	5350 (11800)	4670 (10300)	3710 (8180)	2730 (6030)	2170 (4780)	1900 (4180)	1720 (3800)	1620 (3570)	1500 (3320)	1370 (3010)	1290 (2840)				
213	X12	—	—	—	—	5850 (12900)	5110 (11300)	4060 (8940)	2990 (6590)	2370 (5230)	2070 (4570)	1880 (4150)	1770 (3910)	1650 (3630)	1490 (3300)	1410 (3100)				
214	X13	—	—	—	—	6350 (14000)	5550 (12200)	4400 (9710)	3240 (7150)	2580 (5680)	2250 (4960)	2040 (4510)	1920 (4240)	1790 (3940)	1620 (3580)	1530 (3370)				
215	X14	—	—	—	—	6750 (14900)	5900 (13000)	4680 (10300)	3450 (7600)	2740 (6040)	2390 (5270)	2170 (4790)	2040 (4510)	1900 (4180)	1720 (3800)	1620 (3580)				
216	X15	—	—	—	—	7400 (16300)	6460 (14300)	5130 (11300)	3780 (8340)	3000 (6620)	2620 (5780)	2380 (5250)	2240 (4940)	2080 (4590)	1890 (4170)					
217	X16	—	—	—	—	8500 (18700)	7430 (16400)	5890 (13000)	4340 (9570)	3450 (7600)	3010 (6640)	2740 (6030)	2570 (5680)	2390 (5270)	2170 (4790)					
218	X17	—	—	—	—	9750 (21500)	8520 (18800)	6760 (14900)	4980 (11000)	3950 (8720)	3450 (7620)	3140 (6920)	2950 (6510)	2740 (6040)	2490 (5490)					
—	X18	—	—	—	—	11100 (24500)	9700 (21400)	7700 (17000)	5670 (12500)	4500 (9920)	3930 (8670)	3570 (7880)	3360 (7410)	3120 (6890)						
—	X20	—	—	—	—	13700 (30200)	12000 (26400)	9500 (20900)	7000 (15400)	5560 (12200)	4850 (10700)	4410 (9720)	4150 (2150)	3850 (8490)						

Radial load rating in kilograms (Pounds)

Note : Radial load rating of SER 200 Series is same as UC 200 Series.

Heavy duty type

Bearing No.		Radial load rating at various rpm													
UC 300	UK 300	33 1/3	50	100	250	500	750	1000	1200	1500	2000	2400	3600	5000	rpm
305	305	2170 (4780)	1900 (4180)	1500 (3320)	1110 (2440)	880 (1940)	770 (1700)	700 (1540)	655 (1450)	610 (1350)	555 (1220)	520 (1150)	455 (1010)	410 (900)	
306	306	2730 (6020)	2390 (5260)	1890 (4170)	1400 (3080)	1110 (2440)	965 (2130)	880 (1940)	825 (1820)	765 (1690)	695 (1540)	655 (1450)	575 (1260)	515 (1130)	
307	307	3400 (7500)	2970 (6560)	2360 (5200)	1740 (3830)	1380 (3040)	1200 (2660)	1090 (2410)	1030 (2270)	955 (2110)	870 (1920)	815 (1800)	715 (1570)		
308	308	4150 (9150)	3630 (7990)	2880 (6340)	2120 (4670)	1680 (3710)	1470 (3240)	1340 (2950)	1260 (2770)	1170 (2570)	1060 (2340)	995 (2200)	870 (1920)		
309	309	5250 (11570)	4580 (10100)	3640 (8030)	2680 (5910)	2130 (4690)	1860 (4100)	1680 (3730)	1580 (3510)	1480 (3250)	1340 (2960)	1260 (2780)	1100 (2430)		
310	310	6300 (13900)	5500 (12100)	4370 (9630)	3220 (7100)	2550 (5630)	2230 (4920)	2030 (4470)	1910 (4210)	1770 (3910)	1610 (3550)	1510 (3340)			
311	311	7300 (16100)	6380 (14100)	5000 (11200)	3730 (8220)	2960 (6530)	2590 (5700)	2350 (5180)	2210 (4870)	2050 (4530)	1870 (4110)	1760 (3870)			
312	312	8300 (18300)	7250 (16000)	5750 (12700)	4240 (9350)	3370 (7420)	2940 (6480)	2670 (5890)	2510 (5540)	2330 (5150)	2120 (4670)	2000 (4400)			
313	313	9450 (20800)	8280 (18200)	6580 (14400)	4830 (10600)	3830 (8450)	3350 (7380)	3040 (6710)	2860 (6310)	2660 (5860)	2410 (5320)	2270 (5010)			
314	314	10900 (23400)	9260 (20400)	7350 (16200)	5420 (11940)	4300 (9480)	3750 (8280)	3400 (7520)	3210 (7080)	2980 (6580)	2710 (5970)	2590 (5620)			
315	315	11900 (25800)	10100 (22300)	8040 (17700)	6300 (13100)	4700 (10400)	4110 (9060)	3730 (8230)	3510 (7750)	3260 (7190)	2980 (6530)				
316	316	12500 (27600)	10900 (24100)	8670 (19100)	6390 (14100)	5070 (11200)	4430 (9760)	4020 (8870)	3790 (8390)	3510 (7750)	3190 (7040)				
317	317	13500 (29800)	11800 (26000)	9360 (20900)	6900 (15200)	5470 (12100)	4780 (10500)	4340 (9580)	4090 (9010)	3800 (8370)	3450 (7600)				
318	318	14600 (32200)	12800 (28100)	10100 (22300)	7460 (16400)	5920 (13100)	5170 (11400)	4700 (10400)	4430 (9790)	4100 (9050)					
319	319	15800 (34400)	13800 (30000)	10800 (23800)	7970 (17600)	6330 (13900)	5530 (12200)	5020 (11100)	4720 (10400)	4390 (9670)					
320	320	17700 (39000)	15460 (34100)	12300 (27100)	9040 (19900)	7180 (15800)	6370 (13900)	5700 (12600)	5360 (11800)	4980 (11000)					
321	321	18700 (41200)	16300 (36000)	13000 (28600)	9550 (21100)	7580 (16720)	6620 (14600)	6020 (13300)	5660 (12500)	5260 (11600)					
322	322	20900 (46100)	18300 (40300)	14500 (32000)	10700 (23500)	8470 (18700)	7400 (16300)	6730 (14800)	6330 (14000)						
324	324	21100 (46500)	18400 (40600)	14600 (32300)	10800 (23900)	8560 (18900)	7470 (16500)	6790 (15000)	6390 (14100)						
326	326	23400 (51800)	20400 (45100)	16200 (35800)	12000 (26400)	9490 (20900)	8290 (18300)	7530 (16600)	7090 (15600)						
328	328	26000 (57300)	22700 (50100)	18000 (39700)	13300 (29300)	10600 (23200)	9210 (20300)	8370 (18400)	7870 (17400)						

Radial load rating in kilograms (pounds)

Silver series

Bearing No.		Radial load rating at various rpm													
U000		33 1/3	50	100	250	500	750	1000	1200	1500	2000	2400	3600	5000	rpm
000		470 (1040)	410 (905)	325 (720)	240 (530)	190 (420)	165 (365)	150 (335)	140 (315)	130 (290)	120 (265)	115 (250)	100 (220)	90 (195)	
001		520 (1150)	455 (1000)	360 (795)	265 (585)	210 (465)	185 (405)	165 (370)	155 (345)	145 (320)	135 (295)	125 (275)	110 (240)	100 (215)	
002		570 (1260)	500 (1100)	395 (870)	290 (640)	230 (510)	200 (445)	185 (405)	175 (380)	160 (355)	145 (320)	135 (300)	120 (265)	105 (235)	
003		610 (1340)	535 (1180)	425 (935)	310 (685)	245 (545)	215 (475)	195 (435)	185 (405)	170 (380)	155 (345)	145 (325)	130 (280)	115 (255)	
004		955 (2110)	835 (1840)	660 (1460)	490 (1080)	385 (855)	340 (745)	305 (680)	290 (640)	270 (590)	245 (540)	230 (505)	200 (440)	180 (395)	
005		1030 (2270)	900 (1980)	715 (1580)	525 (1150)	420 (920)	365 (805)	330 (730)	310 (690)	290 (640)	265 (580)	250 (545)	215 (475)	195 (425)	
006		1350 (2980)	1180 (2600)	935 (2090)	690 (1520)	545 (1210)	480 (1050)	435 (960)	410 (900)	380 (830)	345 (760)	325 (715)	285 (625)	255 (560)	
007		1630 (3600)	1420 (3140)	1130 (2490)	835 (1840)	660 (1460)	575 (1270)	525 (1160)	495 (1090)	460 (1010)	415 (920)	390 (865)	340 (755)	308 (675)	
U 08		340 (750)	295 (660)	235 (520)	175 (385)	140 (305)	120 (265)	110 (240)	105 (225)	95 (210)	85 (190)	80 (180)	70 (155)	65 (140)	

Radial load rating in kilograms (pounds)

Kg - N
CONVERSION TABLE OF
BASIC LOAD RATING

Light, Normal and Medium duty type

Bearing No.						Basic dynamic load rating		Basic static load rating	
UC 200 UK 200	UC X00 UK X00	UD 200	B	UG 200	KH 200	C		Co	
						Kgf	N	Kgf	N
(UCW 200) (201 - 203)	—	—	1 - 3	201 - 203	201 - 203	975	9550	455	4450
201 - 204		204	4	204	204	1310	12800	630	6200
205		205	5	205	205	1430	14000	710	6950
206	X05	206	6	206	206	2000	19600	1020	10000
207	X06	207	7	207	207	2640	25900	1400	13700
208	X07	208		208	208	2990	29300	1600	15700
209	X08	209		209	209	3350	33000	1810	17800
210	X09	210		210	210	3600	35500	2010	19700
211	X10			211	211	4400	43000	2550	25000
212	X11			212		5350	52500	3150	31000
213	X12					5850	57500	3500	34000
214	X13					6350	62000	3800	37500
215	X14					6750	66000	4200	41000
216	X15					7400	72500	4550	44500
217	X16					8500	83500	5500	52000
218	X17					9750	95500	6300	60500
	X18					11100	109000	7100	69500
	X20					13700	134000	9100	89000

Note:

For SER 200 Series, take load rating of corresponding UC 200 Series.

U000	470	4600	198	1940
U001	520	5100	229	2240
U002	570	5600	263	2580
U003	610	6000	297	2910
U004	955	9350	470	4610
U005	1030	10100	530	5190
U006	1350	13200	740	7250
U007	1630	15900	915	8970
U 08	340	3300	136	1330

Heavy duty type

Bearing No.	Basic dynamic load rating		Basic static load rating	
UC 300 UK 300	C		Co	
	Kgf	N	Kgf	N
305	2170	21300	1090	10600
306	2730	26800	1420	13900
307	3400	33500	1820	17800
308	4150	40500	2270	22300
309	5250	51500	3050	27200
310	6300	61500	3650	35500
311	7300	71500	4250	41500
312	8300	81500	4900	48500
313	9450	92500	5650	55500
314	10600	104000	6450	63000
315	11600	114000	7200	71500
316	12500	123000	8150	80000
317	13500	132000	9100	89000
318	14600	143000	10100	99000
319	15600	153000	11100	109000
320	17700	173000	13300	131000
321	18700	183000	14500	142000
322	20900	205000	17000	167000
324	21100	207000	17000	167000
326	23400	229000	19600	194000
328	26000	255000	22400	222000

ASAHI JOINBAL

ROD ENDS SPHERICAL BEARINGS



TYPES AND CONSTRUCTION OF JOINBAL

JA SERIES 3-Piece Construction Lubricatable

		<u>Page</u>
JAF	Female Rod End	82
JAM	Male Rod End	



FB SERIES PTFE Lined (*) Self-lubricated

		<u>Page</u>
FBF	Female Rod End	83
FBM	Male Rod End	

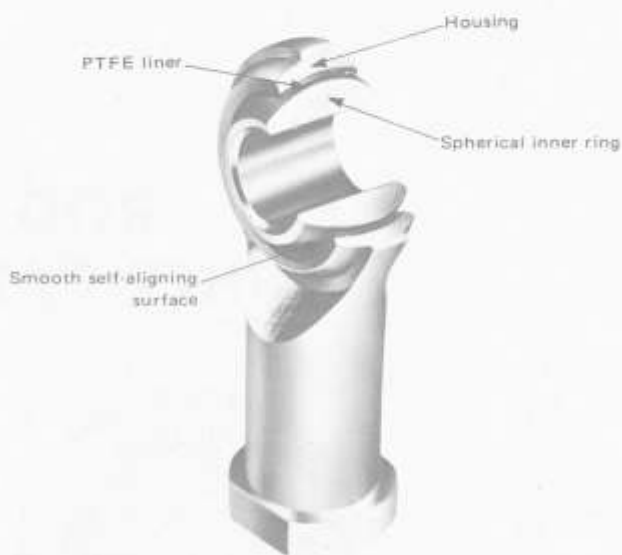

*PTFE : Reinforced Poly Tetra Fluoro Ethylene Resin

JH SERIES 2-Piece Construction Lubricatable

		<u>Page</u>
JHF	Female Rod End (*)	84
JHM	Male Rod End	

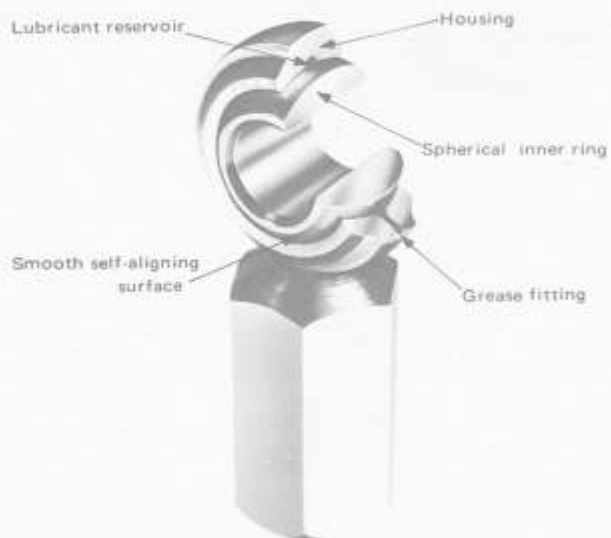

(*) Hexagonal Shank
(Design Application pending)

SPHERICAL BEARINGS

		<u>Page</u>
JAS	3-Piece Construction	85
JBS	2-Piece Construction	

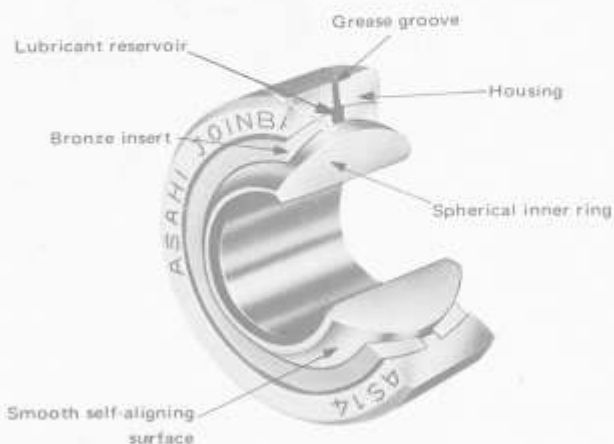

FEATURES OF JOINBAL

High reliability

JOINBAL is manufactured with high technic attained through long experiences in production of precision bearings and it assures high reliability.

Smooth self-alignment

JOINBAL is provided with smooth self-alignment between superfinished spherical outside diameter of the inner ring and mating spherical inside diameter of the inserts or housing compensating for alignment errors or shaft deflection of the machine.

Large angle of misalignment

JOINBAL has a large angle of misalignment for smooth transmission of any complex motion.

Large load carrying capacity

JOINBAL is capable to carry radial, axial, heavy or shock load and any combined loads of any of them as it is accurately machined and assembled using selected materials for the inner ring, inserts and housing.

High wear-resistance

JOINBAL has high wear-resistance capability with high quality materials.

Easy handling

JOINBAL is a compact assembly and as it is ready for immediate application to the machine, installation is easy and free from troubles.

NUMBERING SYSTEM OF JOINBAL

Series Symbol	Housing Type Symbol	Bore Diameter Number
JA : 3-piece construction with copper alloy insert	F : Female Rod End	To indicate bore diameter of inner ring in millimeter
FB : Reinforced PTFE lined	M : Male Rod End	
JH : 2-piece construction JB : 2-piece construction	S : Spherical Bearings	

Note; For left-hand thread of Rod End types, add "L" to Rod End Number (Example : JAF^L5)

EXAMPLES

<p>J A F 10</p> <p>— Bore diameter 10mm</p> <p>— Female Rod End</p> <p>— 3-piece construction</p>	<p>F B F 8</p> <p>— Bore diameter 8mm</p> <p>— Female Rod End</p> <p>— PTFE lined</p>
<p>J H M 15</p> <p>— Bore diameter 15mm</p> <p>— Male Rod End</p> <p>— 2-piece construction</p>	<p>J A S 20</p> <p>— Bore diameter 20mm</p> <p>— Spherical Bearing</p> <p>— 3-piece construction</p>

Female Rod End

* FBF type

PTFE Lined
Self-lubricated

Materials:

Housing — Carbon Steel
Unichrome plated

Ball — High Carbon Chromium Bearing Steel

Liner — Reinforced Poly Tetra
Fluoro Ethylene Resin

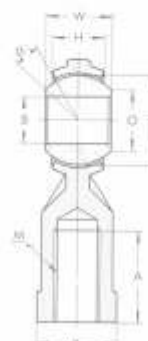
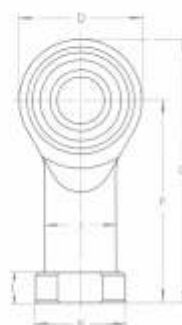

No.	Dimensions (mm)														Misalign- ment °	Minimum Static Fracture Radial Load (kg)	Maximum Static Load (kg)		wt. (g)
	B	W	H	O	D	F	G	A	K	X	J	L	E	M			Radial	Axial	
FBF 5	5	8	7	7.7	16	27	36	12.5	12	10	9	4	11.11	M 5x0.8	7	880	590	230	16
FBF 6	6	9	7	9	18	30	39	13.5	13	11	10	5	12.7	M 6x1	11	1000	650	250	20
FBF 8	8	12	9	10.4	22	36	47	16	16	14	12.5	5	15.88	M 8x1.25	14	1200	800	300	37
FBF 10	10	14	11	12.9	26	43	56	19.5	19	17	15	6.5	19.05	M10x1.5	12	1550	1050	390	61
FBF 12	12	16	12	15.4	30	50	65	24	22	19	17.5	6.5	22.23	M12x1.75	13	1950	1300	500	89
FBF 14	14	19	14	16.9	34	57	74	27	25	22	20	8	25.4	M14x2	14	2550	1700	650	135
FBF 16	16	21	15	19.4	38	64	83	33	27	22	22	8	28.58	M16x2	15	3150	2100	800	171
FBF 18	18	23	17	21.9	42	71	92	36	31	27	25	10	31.75	M18x1.5	14	3800	2550	950	246
FBF 20	20	25	18	24.4	46	77	100	40	34	30	27.5	10	34.93	M20x1.5	14	4500	3000	1100	314
FBF 22	22	28	20	25.8	50	84	109	43	37	32	30	12	38.1	M22x1.5	15	5300	3550	1350	410

Male Rod End

* FBM type

PTFE Lined
Self-lubricated

Materials:

Housing — Carbon Steel
Unichrome plated

Ball — High Carbon Chromium Bearing Steel

Liner — Reinforced Poly Tetra
Fluoro Ethylene Resin

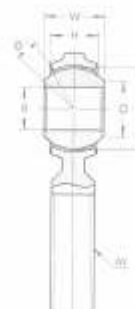

No.	Dimensions (mm)										Misalign- ment °	Minimum Static Fracture Radial Load (kg)	Maximum Static Load (kg)		wt. (g)
	B	W	H	O	D	F	G	A	E	M			Radial	Axial	
FBM 5	5	8	7	7.7	16	33	41	20	11.11	M 5x0.8	7	400	250	100	11
FBM 6	6	9	7	9	18	36	45	22	12.7	M 6x1	11	600	400	150	15
FBM 8	8	12	9	10.4	22	42	53	25	15.88	M 8x1.25	14	1100	750	300	30
FBM 10	10	14	11	12.9	26	48	61	29	19.05	M10x1.5	12	1550	1050	400	48
FBM 12	12	16	12	15.4	30	54	69	33	22.23	M12x1.75	13	1950	1300	500	76
FBM 14	14	19	14	16.9	34	60	77	36	25.4	M14x2	14	2550	1700	650	115
FBM 16	16	21	15	19.4	38	66	85	40	28.58	M16x2	15	3150	2100	800	159
FBM 18	18	23	17	21.9	42	72	93	44	31.75	M18x1.5	14	3800	2550	950	222
FBM 20	20	25	18	24.4	46	78	101	47	34.93	M20x1.5	14	4500	3000	1150	292
FBM 22	22	28	20	25.8	50	84	109	51	38.1	M22x1.5	15	5310	3550	1350	381

Note : For left-hand thread, add "L" to rod end number (Example : FBML 5).
Assembly with chrome plated ball on inside diameter available on special order.
Stainless Steel housing and ball available on special order.

Female Rod End

JHF type

2-Piece Construction with Hexagonal Shank

Lubricatable

Materials:

- Housing — Carbon Steel
Nickel plated
- Ball — High Carbon Chromium Bearing Steel

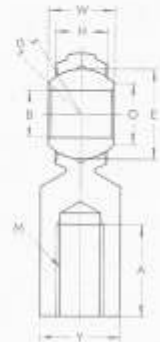
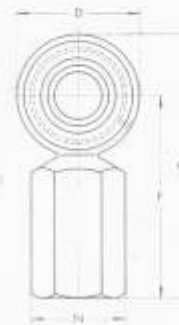

No.	Dimensions (mm)												Misalignment α 2	Minimum Static Fracture Radial Load (kg)	Maximum Static Load (kg)		wt. (g)
	B	W	H	O	D	F	G	A	N	Y	E	M			Radial	Axial	
JHF 5	5	8	7	7,7	16	27	35	12,5	9,2	8	11,11	M 5x0,8	7	430	290	350	19
JHF 6	6	9	7	9	18	30	39	13,5	11,5	10	12,7	M 6x1	11	690	460	480	25
JHF 8	8	12	9	10,4	22	36	47	16	13,9	12	15,88	M 8x1,25	14	770	510	690	47
JHF 10	10	14	11	12,9	28	43	56	19,5	16,2	14	19,05	M10x1,5	12	1520	1010	1070	78
JHF 12	12	16	12	15,4	30	50	65	24	19,6	17	22,23	M12x1,75	13	1810	1210	1390	111
JHF 14	14	19	14	16,9	34	57	74	27	21,9	19	25,4	M14x2	14	2900	1930	1900	168
JHF 18	16	21	15	19,4	38	64	83	33	25,4	22	28,58	M16x2	15	3020	2010	2320	192
JHF 18	18	23	17	21,9	42	71	92	36	27,7	24	31,75	M18x1,5	14	4040	2690	2980	306
JHF 20	20	25	18	24,4	46	77	100	40	31,2	27	34,93	M20x1,5	14	5130	3420	3490	400

Male Rod End

JHM type

2-Piece construction

Lubricatable

Materials:

- Housing — Carbon Steel
Chrome plated
- Ball — High Carbon Chromium Bearing Steel

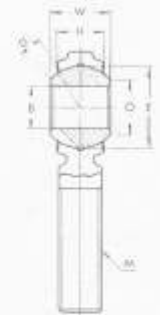
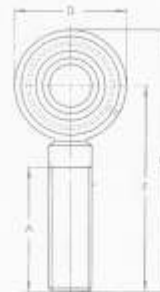

No.	Dimensions (mm)										Misalignment α 3	Minimum Static Fracture Radial Load (kg)	Maximum Static Load (kg)		wt. (g)
	B	W	H	O	D	F	G	A	E	M			Radial	Axial	
JHM 5	5	8	7	7,7	16	33	41	20	11,11	M 5x0,8	7	430	290	350	11
JHM 6	6	9	7	9	18	36	45	22	12,7	M 6x1	11	690	460	480	16
JHM 8	8	12	9	10,4	22	42	53	25	15,88	M 8x1,25	14	770	510	690	30
JHM 10	10	14	11	12,9	26	48	61	29	19,05	M10x1,5	12	1520	1010	1070	50
JHM 12	12	16	12	15,4	30	54	69	33	22,23	M12x1,75	13	1810	1210	1390	77
JHM 14	14	19	14	16,9	34	60	77	36	25,4	M14x2	14	2900	1930	1900	114
JHM 18	16	21	15	19,4	38	66	85	40	28,58	M16x2	15	3020	2010	2320	161
JHM 18	18	23	17	21,9	42	72	93	44	31,75	M18x1,5	14	4040	2690	2980	221
JHM 20	20	25	18	24,4	46	78	101	47	34,93	M20x1,5	14	5130	3420	3490	292

Note : For left-hand thread, add "L" to rod end number (Example : JHML 5).
Assembly with sintered alloy ball available on special order.

Spherical Bearings

JAS type

3-Piece construction

Lubricatable

Materials:

Housing — Carbon Steel
Unichrome plated

Ball — High Carbon Chromium Bearing Steel

Insert — Copper Alloy

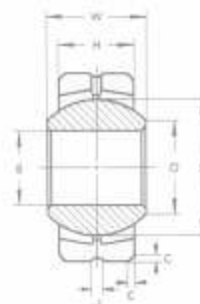

No.	Dimensions (mm)								Misalignment			Maximum Static Load (kg)		wt. (g)
	B	W	H	O	D	C	J	E	$\alpha 1$	$\alpha 2$	$\alpha 3$	Radial	Axial	
JAS 5	5	8	7	7.71	16	0.5	1.5	11.11	3	7	24	930	230	10
JAS 6	6	9	7	8.96	18	0.5	1.5	12.7	6	11	28	1070	270	12
JAS 8	8	12	9	10.4	22	0.5	1.5	15.88	8	14	25	1720	430	24
JAS 10	10	14	11	12.92	26	0.5	1.5	19.05	7	12	23	2510	630	40
JAS 12	12	16	12	15.43	30	1	2	22.23	8	13	24	3200	800	58
JAS 14	14	19	14	16.86	34	1	2	25.4	9	14	23	4270	1070	86
JAS 15	15	20	14	18.12	36	1	2	26.99	10	16	24	4530	1130	98
JAS 16	16	21	15	19.39	38	1	2	28.58	9	15	24	5140	1290	116
JAS 17	17	22	16	20.63	40	1	2.5	30.16	9	14	23	5790	1450	135
JAS 18	18	23	17	21.89	42	1.5	2.5	31.75	9	14	23	6480	1620	157
JAS 20	20	25	18	24.38	46	1.5	2.5	34.93	9	14	24	7540	1890	200
JAS 22	22	28	20	25.84	50	1.5	2.5	38.1	10	15	23	9140	2290	262
JAS 25	25	31	22	29.6	56	1.5	3	42.86	10	15	23	11320	2830	362
JAS 28	28	35	25	32.29	62	1.5	3	47.63	10	15	22	14290	3570	500
JAS 30	30	37	26	34.81	67	2	3	50.8	10	15	23	15850	3960	608

Spherical Bearings

JBS type

2-Piece construction

Lubricatable

Materials:

Housing — High Carbon Chromium Bearing Steel
Unichrome plated

Ball — High Carbon Chromium Bearing Steel

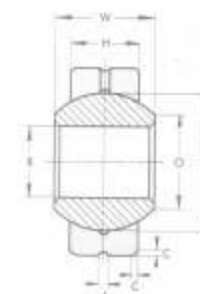
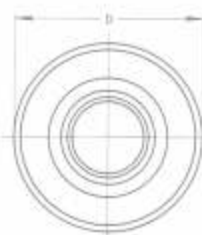

No.	Dimensions (mm)								Misalignment			Maximum Static Load (kg)		wt. (g)
	B	W	H	O	D	C	J	E	$\alpha 1$	$\alpha 2$	$\alpha 3$	Radial	Axial	
JBS 5	5	8	5.6	7.71	16	0.5	1.5	11.11	9	15	32	2490	620	8
JBS 6	6	9	6.4	8.96	18	0.5	1.5	12.7	9	14	31	3250	810	11
JBS 8	8	12	7.9	10.4	22	0.5	1.5	15.88	11	19	29	5020	1260	21
JBS 10	10	14	9.5	12.92	26	0.5	1.5	19.05	10	17	28	7250	1810	35
JBS 12	12	16	11.1	15.43	30	1	2	22.23	10	16	27	9870	2470	53
JBS 14	14	19	12.5	16.86	34	1	2	25.4	11	18	26	12900	3220	77
JBS 15	15	20	13.5	18.12	36	1	2	26.99	11	17	26	14570	3840	91
JBS 16	16	21	14.3	19.39	38	1	2	28.58	11	17	25	16350	4090	107
JBS 17	17	22	15.1	20.63	40	1	2.5	30.16	10	16	25	18220	4560	125
JBS 18	18	23	15.9	21.89	42	1.5	2.5	31.75	11	16	25	20190	5050	150
JBS 20	20	25	17.5	24.38	46	1.5	2.5	34.93	10	15	25	24450	6110	187

Female Rod End **CETOP-standard**

JAF-S(CETOP-type)

3-Piece construction

Lubricatable

Materials:

Housing — Carbon Steel

— Unichrome plated

Ball — High Carbon Chromium Bearing

— Steel

Insert — Copper Alloy

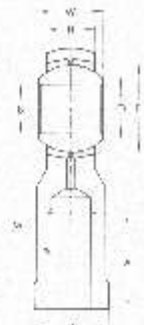
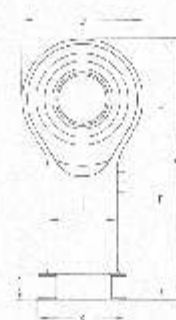

No.	Dimensions (mm)														Misalignment			Minimum Static Fracture Radial Load (kg)	Maximum Static Load (kg)		wt. (g)	
	B	W	H	G	D	F	G	A	C	X	J	L	E	M	e1	e2	e3		Radial	Axial		
JAF 10S	10	14	11	12	92	26	43	56	21	19	17	15	6.5	19.06	M10×1.25	7	12	23	2010	1340	630	78
JAF 12S	12	16	12	15	43	30	50	65	24	22	19	17.5	6.5	22.23	M12×1.25	8	13	24	2470	1650	800	114
JAF 16S	16	21	15	18	39	38	64	83	33	27	22	22	8	28.58	M16×1.5	10	15	24	3700	2470	1290	200
JAF 30S	30	37	26	34	81	67	110	143.5	53	50	41	40	15	50.8	M27×2	10	15	23	11000	7370	3960	1050

ENGINEERING DATA

1. TOLERANCES

Table 1.1

Tolerance	Unit : mm
Machined parts	Tolerance
Bore diameter of spherical ball	H7
Width of spherical ball	0 -0.1
Outside diameter of housings (JAS and JBS types Spherical Bearings)	0 -0.012

Table 1.2

Maximum clearance	Unit : mm
Radial clearance	Max. 0.05
Axial clearance	Max. 0.15

2. LOAD CAPACITY

MINIMUM STATIC FRACTURE RADIAL LOADS are based on the yield point of body causing the interference with ball rotation by hand in non-loaded state after the catalog loads were applied for one minute in a static condition.

LIMIT RADIAL LOADS represent the limiting radial loads which may permit smooth ball rotation based on the experimental test conducted by applying 2.5kg radial load after unloading the catalog loads applied for one minute in a static condition.

LIMIT AXIAL LOADS represent the limiting axial load which may permit smooth ball rotation based on the experimental test conducted by applying 2.5kg radial load after unloading the catalog loads applied for one minute in a static condition.

3. SHAFT SELECTION

Correct shaft tolerance shall be selected, depending on the operating load and kind of loads expected in the actual application, to have a right fitting between the shaft and Rod Ends, or between outer diameter of Spherical Bearings

and inside diameter of the housing of machines. The following tables show the recommended tolerances. The shaft on which JOINBAL is to be mounted should be free from bend and bruise.

Table 3.1

Recommended shaft tolerance for Rod Ends.

Unit: 0.001mm

Nominal shaft size (mm)		n6	p6	r6
over	incl.			
3	6	+16 ~ + 8	+20 ~ +12	+23 ~ +15
6	10	+19 ~ +10	+24 ~ +15	+28 ~ +19
10	18	+23 ~ +12	+29 ~ +18	+34 ~ +23
18	30	+28 ~ +15	+35 ~ +22	+41 ~ +28

Note: When the load is particularly large, use r6.

Table 3.2

Recommended shaft tolerance for Spherical Bearings.

Unit: 0.001mm

Nominal inside diameter (mm)		J7	K7	M7
Over	incl.			
10	18	+10 ~ - 8	+6 ~ -12	0 ~ -18
18	30	+12 ~ - 9	+6 ~ -15	0 ~ -21
30	50	+14 ~ -11	+7 ~ -18	0 ~ -25
50	80	+18 ~ -12	+9 ~ -21	0 ~ -30

4. MOUNTING INSTRUCTIONS

For normal applications, use press fitting on the shaft as shown in Fig. 4.1 (a). Where complex movements, combined or fluctuating loads are expected, it is recommended to lock by means of

nut or bolt after staking the spherical ball into the shaft as shown in Figs (b), (c) and (d).

When mounting on the shaft, use a plate on the face of the spherical ball.

Fig. 4.1

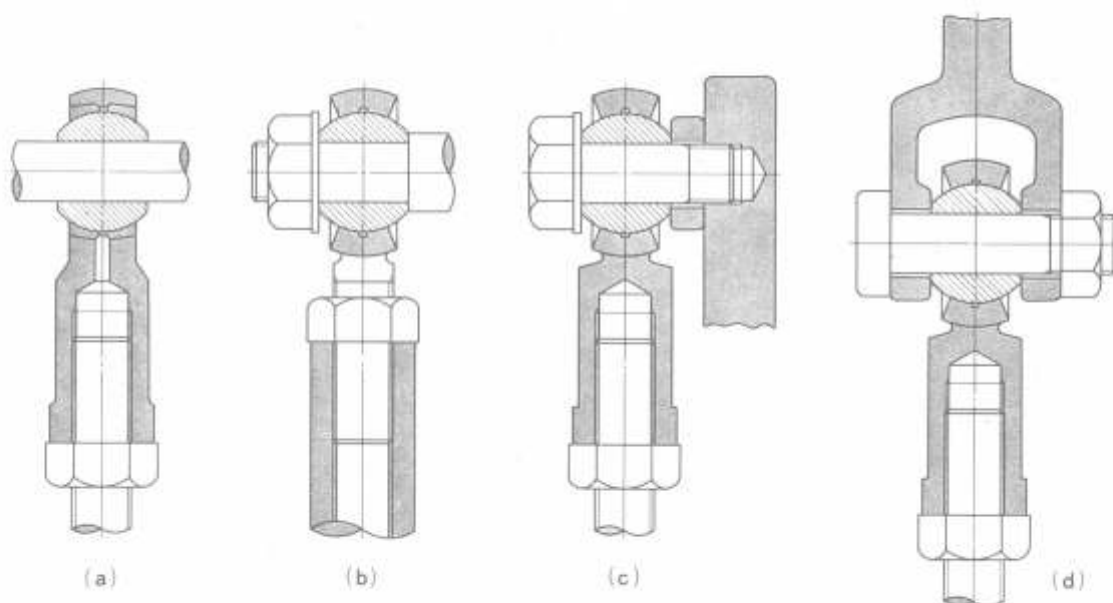

5. ANGLE OF MISALIGNMENT

There are three different types of mounting in which JOINBAL may be used, as illustrated below, and the angle of misalignment varies according to the type of mounting adopted. Angle of misalignment is shown in each dimension table.

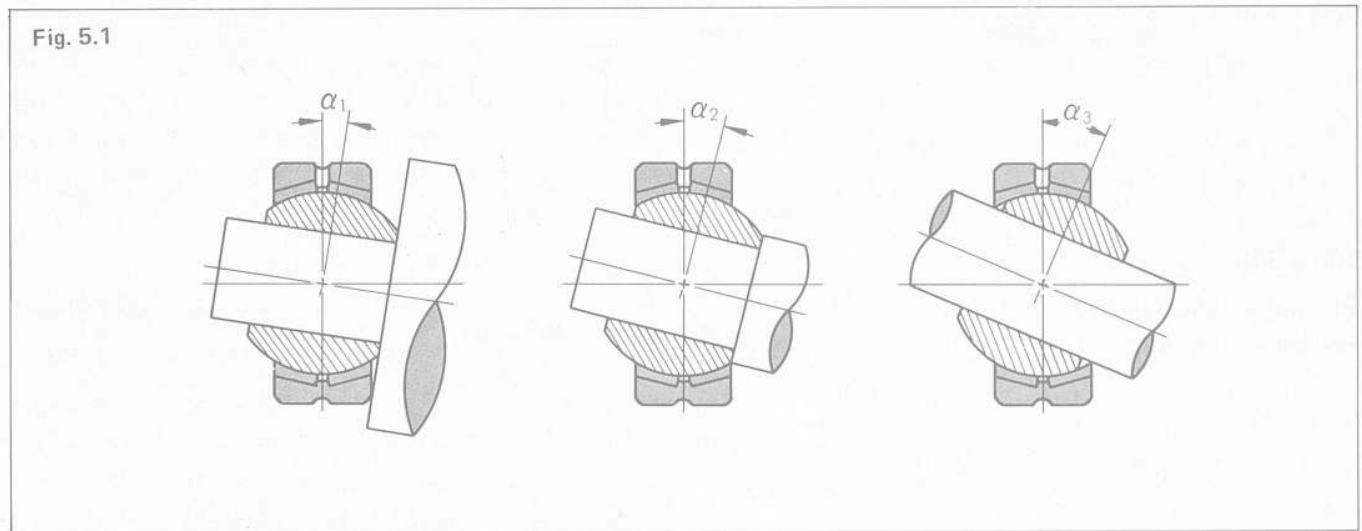

6. LIMITING OPERATING SPEED

The limiting operating speed of JOINBAL is determined by the load and peripheral velocity of the spherical ball. The maximum peripheral velocity, in case of light load, is 50m/min. Fig. 6.1 shows the coefficient between bore diameter and allowable speed.

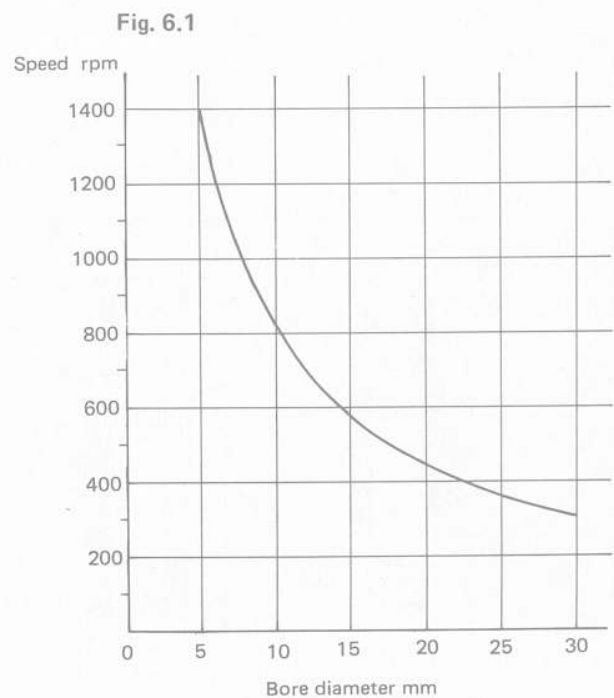

7. LUBRICATION

JOINBAL is normally lubricated with grease. The grease is pumped in through grease hole on the housing of Rod Ends, or supplied into the grease reservoir through grease groove on the outside diameter of Spherical Bearings.

Note: As JOINBAL is not factory-lubricated, lubricate it when mounting on the shaft.

Select proper grease with care, among many kinds of grease available, to meet the specific application. Generally, lithium-based grease having the advantages in water-resistance, heat-resistance and mechanical-stability for both high and low operating temperature, is recommended.

JOINBAL should be relubricated while it is rotating with a proper amount of grease until the newly supplied grease oozes out between the spherical ball and housing.

The length of interval between greasing is dependent on the operating conditions and type of grease. The following Fig. 7.1 covers most situation and can be used as a guide. Generally, the range of operating temperature is $-15^{\circ}\text{C} \sim +100^{\circ}\text{C}$.

Note: For applications where operating temperature exceeds $+100^{\circ}\text{C}$, consult us.

Fig. 7.1

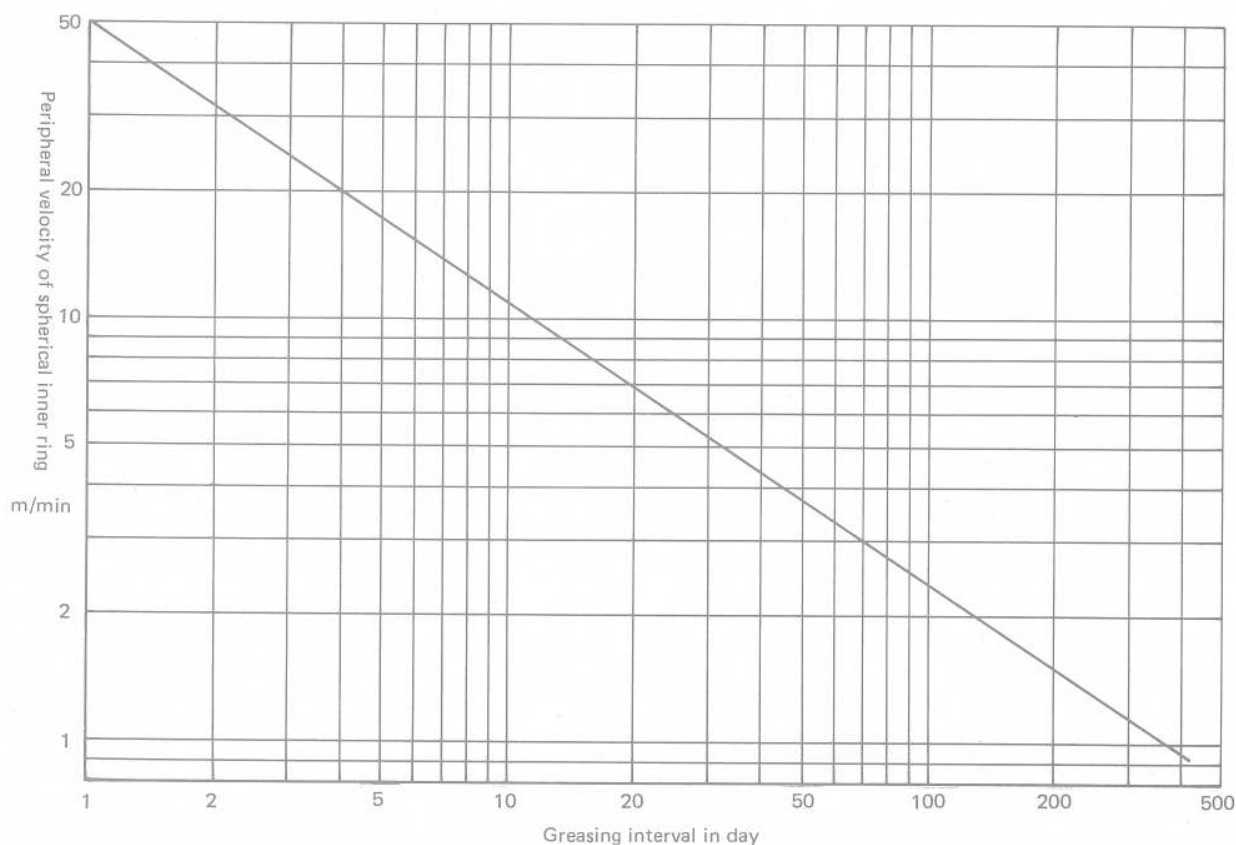

CONVERSION TABLE OF INCHES INTO MILLIMETERS

1 inch=25.4mm

Inch		0	1	2	3	4	5	6	7	8	9
Fractional	Decimal										
	0		25.400	50.800	76.200	101.600	127.000	152.400	177.800	203.200	228.600
$\frac{1}{16}$	$\frac{1}{16}$.015625	0.397	25.797	51.197	76.597	101.997	127.397	152.797	178.197	203.597
$\frac{1}{8}$	$\frac{1}{8}$.031250	0.794	26.194	51.594	76.994	102.394	127.794	153.194	178.594	203.994
$\frac{3}{16}$	$\frac{3}{16}$.046875	1.191	26.591	51.991	77.391	102.791	128.191	153.591	178.991	204.391
$\frac{1}{4}$	$\frac{1}{4}$.062500	1.588	26.988	52.388	77.788	103.188	128.588	153.988	179.388	204.788
$\frac{5}{16}$	$\frac{5}{16}$.078125	1.984	27.384	52.784	78.184	103.584	128.984	154.384	179.784	205.184
$\frac{3}{8}$	$\frac{3}{8}$.093750	2.381	27.781	53.181	78.581	103.981	129.381	154.781	180.181	205.581
$\frac{7}{16}$	$\frac{7}{16}$.109375	2.778	28.178	53.578	78.978	104.378	129.778	155.178	180.578	205.978
$\frac{1}{2}$	$\frac{1}{2}$.125000	3.175	28.575	53.975	79.375	104.775	130.175	155.575	180.975	206.375
$\frac{9}{16}$	$\frac{9}{16}$.140625	3.572	28.972	54.372	79.772	105.172	130.572	155.972	181.372	206.772
$\frac{5}{8}$	$\frac{5}{8}$.156250	3.969	29.369	54.769	80.169	105.569	130.969	156.369	181.769	207.169
$\frac{11}{16}$	$\frac{11}{16}$.171875	4.366	29.766	55.166	80.566	105.966	131.366	156.766	182.166	207.566
$\frac{3}{4}$	$\frac{3}{4}$.187500	4.762	30.162	55.562	80.962	106.362	131.762	157.162	182.562	207.962
$\frac{13}{16}$	$\frac{13}{16}$.203125	5.159	30.559	55.959	81.359	106.759	132.159	157.559	182.959	208.359
$\frac{7}{8}$	$\frac{7}{8}$.218750	5.556	30.956	56.356	81.756	107.156	132.556	157.956	183.356	208.756
$\frac{15}{16}$	$\frac{15}{16}$.234375	5.953	31.353	56.753	82.153	107.553	132.953	158.353	183.753	209.153
1	1	.250000	6.350	31.750	57.150	82.550	107.950	133.350	158.750	184.150	209.550
$\frac{1}{8}$	$\frac{1}{8}$.265625	6.747	32.147	57.547	82.947	108.347	133.747	159.147	184.547	209.947
$\frac{9}{16}$	$\frac{9}{16}$.281250	7.144	32.544	57.944	83.344	108.744	134.144	159.544	184.944	210.344
$\frac{5}{8}$	$\frac{5}{8}$.296875	7.541	32.941	58.341	83.741	109.141	134.541	159.941	185.341	210.741
$\frac{11}{16}$	$\frac{11}{16}$.312500	7.938	33.338	58.738	84.138	109.538	134.938	160.338	185.738	211.138
$\frac{3}{4}$	$\frac{3}{4}$.328125	8.334	33.734	59.134	84.534	109.934	135.334	160.734	186.134	211.534
$\frac{13}{16}$	$\frac{13}{16}$.343750	8.731	34.131	59.531	84.931	110.331	135.731	161.131	186.531	211.931
$\frac{7}{8}$	$\frac{7}{8}$.359375	9.128	34.528	59.928	85.328	110.728	136.128	161.528	186.928	212.328
1	1	.375000	9.525	34.925	60.325	85.725	111.125	136.525	161.925	187.325	212.725
$\frac{1}{8}$	$\frac{1}{8}$.390625	9.922	35.322	60.722	86.122	111.522	136.922	162.322	187.722	213.122
$\frac{9}{16}$	$\frac{9}{16}$.406250	10.319	35.719	61.119	86.519	111.919	137.319	162.719	188.119	213.519
$\frac{5}{8}$	$\frac{5}{8}$.421875	10.716	36.116	61.516	86.916	112.316	137.716	163.116	188.516	213.916
$\frac{11}{16}$	$\frac{11}{16}$.437500	11.112	36.512	61.912	87.312	112.712	138.112	163.512	188.912	214.312
$\frac{3}{4}$	$\frac{3}{4}$.453125	11.509	36.909	62.309	87.709	113.109	138.509	163.909	189.309	214.709
$\frac{13}{16}$	$\frac{13}{16}$.468750	11.906	37.306	62.706	88.106	113.506	138.906	164.306	189.706	215.106
$\frac{7}{8}$	$\frac{7}{8}$.484375	12.303	37.703	63.103	88.503	113.903	139.303	164.703	190.103	215.503
1	1	.500000	12.700	38.100	63.500	88.900	114.300	139.700	165.100	190.500	215.900
$\frac{1}{8}$	$\frac{1}{8}$.515625	13.097	38.497	63.897	89.297	114.697	140.097	165.497	190.897	216.297
$\frac{9}{16}$	$\frac{9}{16}$.531250	13.494	38.894	64.294	89.694	115.094	140.494	165.894	191.294	216.694
$\frac{5}{8}$	$\frac{5}{8}$.546875	13.891	39.291	64.691	90.091	115.491	140.891	166.291	191.691	217.091
$\frac{11}{16}$	$\frac{11}{16}$.562500	14.288	39.688	65.088	90.488	115.888	141.288	166.688	192.088	217.488
$\frac{3}{4}$	$\frac{3}{4}$.578125	14.684	40.084	65.484	90.884	116.284	141.684	167.084	192.484	217.884
$\frac{13}{16}$	$\frac{13}{16}$.593750	15.081	40.481	65.881	91.281	116.681	142.081	167.481	192.881	218.281
$\frac{7}{8}$	$\frac{7}{8}$.609375	15.478	40.878	66.278	91.678	117.078	142.478	167.878	193.278	218.678
1	1	.625000	15.875	41.275	66.675	92.075	117.475	142.875	168.275	193.675	219.075
$\frac{1}{8}$	$\frac{1}{8}$.640625	16.272	41.672	67.072	92.472	117.872	143.272	168.672	194.072	219.472
$\frac{9}{16}$	$\frac{9}{16}$.656250	16.669	42.069	67.469	92.869	118.269	143.669	169.069	194.469	219.869
$\frac{5}{8}$	$\frac{5}{8}$.671875	17.066	42.466	67.866	93.266	118.666	144.066	169.466	194.866	220.266
$\frac{11}{16}$	$\frac{11}{16}$.687500	17.462	42.862	68.262	93.662	119.062	144.462	169.862	195.262	220.662
$\frac{3}{4}$	$\frac{3}{4}$.703125	17.859	43.259	68.659	94.059	119.459	144.859	170.259	195.659	221.059
$\frac{13}{16}$	$\frac{13}{16}$.718750	18.256	43.656	69.056	94.456	119.856	145.256	170.656	196.056	221.456
$\frac{7}{8}$	$\frac{7}{8}$.734375	18.653	44.053	69.453	94.853	120.253	145.653	171.053	196.453	221.853
1	1	.750000	19.050	44.450	69.850	95.250	120.650	146.050	171.450	196.850	222.250
$\frac{1}{8}$	$\frac{1}{8}$.765625	19.447	44.847	70.247	95.647	121.047	146.447	171.847	197.247	222.647
$\frac{9}{16}$	$\frac{9}{16}$.781250	19.844	45.244	70.644	96.044	121.444	146.844	172.244	197.644	223.044
$\frac{5}{8}$	$\frac{5}{8}$.796875	20.241	45.641	71.041	96.441	121.841	147.241	172.641	198.041	223.441
$\frac{11}{16}$	$\frac{11}{16}$.812500	20.638	46.038	71.438	96.838	122.238	147.638	173.038	198.438	223.838
$\frac{3}{4}$	$\frac{3}{4}$.828125	21.034	46.434	71.834	97.234	122.634	148.034	173.434	198.834	224.234
$\frac{13}{16}$	$\frac{13}{16}$.843750	21.431	46.831	72.231	97.631	123.031	148.431	173.831	199.231	224.631
$\frac{7}{8}$	$\frac{7}{8}$.859375	21.828	47.228	72.628	98.028	123.428	148.828	174.228	199.628	225.028
1	1	.875000	22.225	47.625	73.025	98.425	123.825	149.225	174.625	200.025	225.425
$\frac{1}{8}$	$\frac{1}{8}$.890625	22.622	48.022	73.422	98.822	124.222	149.622	175.022	200.422	225.822
$\frac{9}{16}$	$\frac{9}{16}$.906250	23.019	48.419	73.819	99.219	124.619	150.019	175.419	200.819	226.219
$\frac{5}{8}$	$\frac{5}{8}$.921875	23.416	48.816	74.216	99.616	125.016	150.416	175.816	201.216	226.616
$\frac{11}{16}$	$\frac{11}{16}$.937500	23.812	49.212	74.612	100.012	125.412	150.812	176.212	201.612	227.012
$\frac{3}{4}$	$\frac{3}{4}$.953125	24.209	49.609	75.009	100.409	125.809	151.209	176.609	202.009	227.409
$\frac{13}{16}$	$\frac{13}{16}$.968750	24.606	50.006	75.406	100.806	126.206	151.606	177.006	202.406	227.806
1	1	.984375	25.003	50.403	75.803	101.203	126.603	152.003	177.403	202.803	228.203

CONVERSION TABLE OF MILLIMETERS INTO INCHES

mm	inch	mm	inch	mm	inch	mm	inch	mm	inch
1	0.0394	51	2.0079	101	3.9764	151	5.9449	201	7.9134
2	0.0787	52	2.0472	102	4.0157	152	5.9043	202	7.9528
3	0.1181	53	2.0866	103	4.0551	153	6.0236	203	7.9921
4	0.1575	54	2.1260	104	4.0945	154	6.0630	204	8.0315
5	0.1969	55	2.1654	105	4.1339	155	6.1024	205	8.0709
6	0.2362	56	2.2047	106	4.1732	156	6.1417	206	8.1102
7	0.2756	57	2.2441	107	4.2126	157	6.1811	207	8.1496
8	0.3150	58	2.2835	108	4.2520	158	6.2205	208	8.1890
9	0.3543	59	2.3228	109	4.2913	159	6.2598	209	8.2283
10	0.3937	60	2.3622	110	4.3307	160	6.2992	210	8.2677
11	0.4331	61	2.4016	111	4.3701	161	6.3386	211	8.3071
12	0.4724	62	2.4409	112	4.4094	162	6.3780	212	8.3465
13	0.5118	63	2.4803	113	4.4488	163	6.4173	213	8.3858
14	0.5512	64	2.5197	114	4.4882	164	6.4567	214	8.4252
15	0.5906	65	2.5591	115	4.5276	165	6.4961	215	8.4646
16	0.6299	66	2.5984	116	4.5669	166	6.5354	216	8.5039
17	0.6693	67	2.6378	117	4.6063	167	6.5748	217	8.5433
18	0.7087	68	2.6772	118	4.6457	168	6.6142	218	8.5827
19	0.7480	69	2.7165	119	4.6850	169	6.6535	219	8.6220
20	0.7874	70	2.7559	120	4.7244	170	6.6929	220	8.6614
21	0.8268	71	2.7953	121	4.7638	171	6.7323	221	8.7008
22	0.8661	72	2.8346	122	4.8031	172	6.7717	222	8.7402
23	0.9055	73	2.8740	123	4.8425	173	6.8110	223	8.7795
24	0.9449	74	2.9134	124	4.8819	174	6.8504	224	8.8189
25	0.9843	75	2.9528	125	4.9213	175	6.8898	225	8.8583
26	1.0236	76	2.9921	126	4.9606	176	6.9291	226	8.8976
27	1.0630	77	3.0315	127	5.0000	177	6.9685	227	8.9370
28	1.1024	78	3.0709	128	5.0394	178	7.0079	228	8.9764
29	1.1417	79	3.1102	129	5.0787	179	7.0472	229	9.0157
30	1.1811	80	3.1496	130	5.1181	180	7.0866	230	9.0551
31	1.2205	81	3.1890	131	5.1575	181	7.1260	231	9.0945
32	1.2598	82	3.2283	132	5.1969	182	7.1654	232	9.1339
33	1.2992	83	3.2677	133	5.2362	183	7.2047	233	9.1732
34	1.3386	84	3.3071	134	5.2756	184	7.2441	234	9.2126
35	1.3780	85	3.3465	135	5.3150	185	7.2835	235	9.2520
36	1.4173	86	3.3858	136	5.3543	186	7.3228	236	9.2913
37	1.4567	87	3.4252	137	5.3937	187	7.3622	237	9.3307
38	1.4961	88	3.4646	138	5.4331	188	7.4016	238	9.3701
39	1.5354	89	3.5039	139	5.4724	189	7.4409	239	9.4094
40	1.5748	90	3.5433	140	5.5118	190	7.4803	240	9.4488
41	1.6142	91	3.5827	141	5.5512	191	7.5197	241	9.4882
42	1.6535	92	3.6220	142	5.5906	192	7.5591	242	9.5276
43	1.6929	93	3.6614	143	5.6299	193	7.5984	243	9.5669
44	1.7323	94	3.7008	144	5.6693	194	7.6378	244	9.6063
45	1.7717	95	3.7402	145	5.7087	195	7.6772	245	9.6457
46	1.8110	96	3.7795	146	5.7480	196	7.7165	246	9.6850
47	1.8504	97	3.8189	147	5.7874	197	7.7559	247	9.7244
48	1.8898	98	3.8583	148	5.8268	198	7.7953	248	9.7638
49	1.9291	99	3.8976	149	5.8661	199	7.8346	249	9.8031
50	1.9685	100	3.9370	150	5.9055	200	7.8740	250	9.8425

CONVERSION TABLE OF KILOGRAMS AND POUNDS

1kg = 2.20462lb
1lb. = 0.45359kg

kg		lb.	kg		lb.	kg		lb.
0.454	1	2.205	15.422	34	74.957	30.391	67	147.71
0.907	2	4.409	15.876	35	77.162	30.844	68	149.91
1.361	3	6.614	16.329	36	79.366	31.298	69	152.12
1.814	4	8.818	16.783	37	81.571	31.751	70	154.32
2.268	5	11.023	17.237	38	83.776	32.205	71	156.53
2.722	6	13.228	17.690	39	85.980	32.659	72	158.73
3.175	7	15.432	18.144	40	88.185	33.112	73	160.94
3.629	8	17.637	18.597	41	90.389	33.566	74	163.14
4.082	9	19.842	19.051	42	92.594	34.019	75	165.35
4.536	10	22.046	19.504	43	94.799	34.473	76	167.55
4.990	11	24.251	19.958	44	97.003	34.927	77	169.76
5.443	12	26.455	20.412	45	99.208	35.380	78	171.96
5.897	13	28.660	20.865	46	101.41	35.834	79	174.16
6.350	14	30.865	21.319	47	103.62	36.287	80	176.37
6.804	15	33.069	21.772	48	105.82	36.741	81	178.57
7.257	16	35.274	22.226	49	108.03	37.195	82	180.78
7.711	17	37.479	22.680	50	110.23	37.648	83	182.98
8.165	18	39.683	23.133	51	112.44	38.102	84	185.19
8.618	19	41.888	23.587	52	114.64	38.555	85	187.39
9.072	20	44.092	24.040	53	116.85	39.009	86	189.60
9.525	21	46.297	24.494	54	119.05	39.463	87	191.80
9.979	22	48.502	24.948	55	121.25	39.916	88	194.01
10.433	23	50.706	25.401	56	123.46	40.370	89	196.21
10.886	24	52.911	25.855	57	125.66	40.823	90	198.42
11.340	25	55.116	26.308	58	127.87	41.277	91	200.62
11.793	26	57.320	26.762	59	130.07	41.730	92	202.83
12.247	27	59.525	27.216	60	132.28	42.184	93	205.03
12.701	28	61.729	27.669	61	134.48	42.638	94	207.23
13.154	29	63.934	28.123	62	136.69	43.091	95	209.44
13.608	30	66.139	28.576	63	138.89	43.545	96	211.64
14.061	31	68.343	29.030	64	141.10	43.998	97	213.85
14.515	32	70.548	29.484	65	143.30	44.452	98	216.05
14.969	33	72.752	29.937	66	145.50	44.906	99	218.26

ASAHI

Wide product range
of high quality.

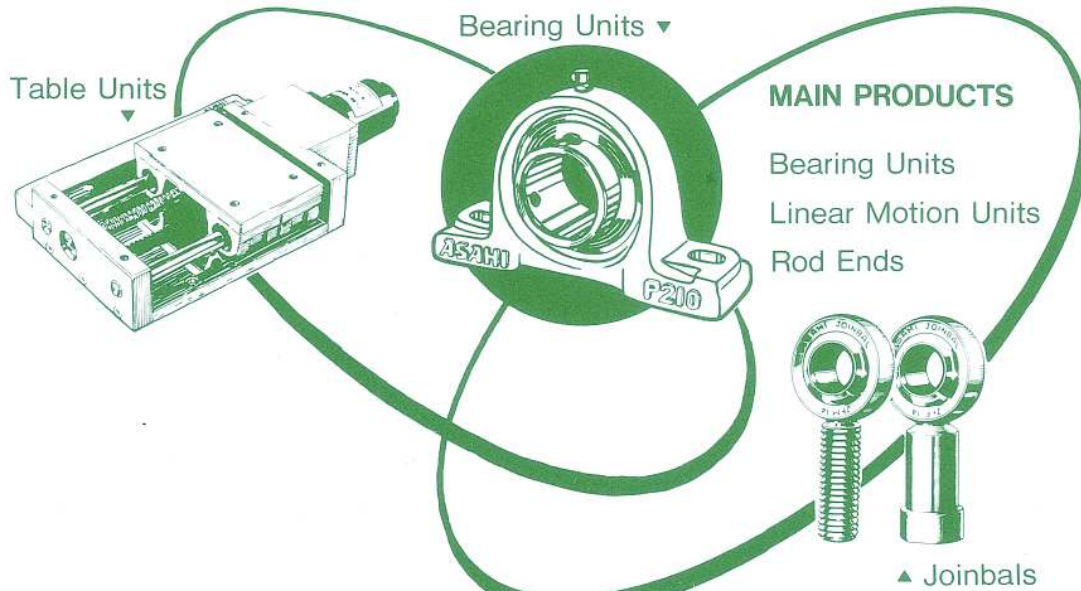

<http://www.asahiseiko.co.jp>

ASAHI SEIKO CO., LTD.

FOREIGN TRADE DEPARTMENT : 570-1, Otori-Higashi-machi 6-cho, Sakai City, Osaka 593-8324, Japan

Tel : +81-72-272-6900

Fax : +81-72-272-6903

e-mail address : ex-1@asahiseiko.co.jp

e-mail address : ex-2@asahiseiko.co.jp

U.S.A. OFFICE : P.O.Box 9108, 570 North Wheeling Road, Mount Prospect, Illinois 60056-9998 U.S.A

Tel : +1-847-759-0620

Fax : +1-847-759-0630

HEAD OFFICE & FACTORY : 570-1, Otori-Higashi-machi 6-cho, Sakai City, Osaka 593-8324, Japan

Tel : +81-72-271-1221

Fax : +81-72-273-0058

